



DRUM TECH AC



DIESEL



ACCESSORIES for all versions

- add-on Filter Kit
- 115V-60Hz motor only on request
- 4 digit flow meter on request
- Tank adapter Kit

FEATURES	60 litre	80 litre	100 litre
Power Supply AC [V, Hz]:	230, 50	230, 50	230, 50
Max Current [A]:	2.4	3.5	4.1
Power [W]:	550	800	950
Motor Protection:	IP 55	IP 55	IP 55
On/Off Switch:	Yes	Yes	Yes
Cable [m]:	2	2	2
Duty Cycle [min]:	S2 30	S2 30	S2 30
Nominal Flow Rate [l/min / GPM]:	60 / 15.85	80 / 21,13	100 / 26,42
Max Pressure [bar / psi]:	2 / 29	2.5 / 36	2.5 / 36
Dry Suction height [m]:	4	2	2
Internal By-Pass:	Yes	Yes	Yes
Inlet [BSP/G]:	1" F	1" F	1" F
Outlet [BSP/G]:	1" F	1" F	1" F
Pump body material:	Cast Iron	Cast Iron	Cast Iron
Impeller material:	Sintered Steel	Sintered Steel	Sintered Steel
Vanes material:	POM	POM	POM
Ring material:	HNBR	HNBR	HNBR
Gasket material:	NBR	NBR	NBR
Flow meter digits:	3	3	3
Flow meter typology:	Oscillating disc	Oscillating disc	Oscillating disc
Flow meter precision [%]:	±1	±1	±1
Repeatability [%]:	0,2	0,2	0,2
Telescopic suction hose:	Yes	Yes	Yes
Delivery Hose [material, ø, m, fittings]:	rubber, 20, 4, 1"x1"	rubber, 25, 4, 1"x1"	rubber, 25, 4, 1"x1"
Nozzle:	automatic / manual	automatic / manual	automatic / manual
Internal Filter:	si	si	si
Motor support:	si	si	si
Min/max Temperature [°C]:	-20/+50	-20/+50	-20/+50
Max fluid viscosity [cSt] (a 40 °C):	2 ÷ 5	2 ÷ 5	2 ÷ 5
Compatible fluids:	diesel	diesel	diesel
Not allowed fluids:	gas, alcohol, water, gasoline, kerosene		
Loudness at less 1 meter [dB]:	< 70	85	85
Net Weight [Kg]:	13.5	20.5	20.5
Gross Weight [Kg]:	14	21	21



Adam Pumps S.p.A.
 via della Resistenza 46/48
 41011 Campogalliano (MO) - ITALIA
 tel. +39 059 528 128 | fax +39 059 528 437
 info@adampumps.com | www.adampumps.com



DRUM TECH DC



DIESEL



Drum Tech 12 Volt



Drum Tech 24 Volt

ACCESSORIES for all versions

- add-on Filter Kit
- 4 digit flow meter on request
- Tank adapter Kit

FEATURES	40L 12V	40L 24V
Power Supply DC [V]:	12	24
Max Current [A]:	21	13
Fuse [A]	30	20
Power [W]:	252	312
Motor Protection:	IP 55	IP 55
On/Off Switch:	Yes	Yes
Cable [m]:	2	2
Duty Cycle [min]:	S2 30	S2 30
Nominal Flow Rate [l/min / GPM]:	40 / 10,57	40 / 10,57
Max Pressure [bar / psi]:	1.3 / 19	1.3 / 19
Dry Suction height [m]:	2	2
Internal By-Pass:	Yes	Yes
Inlet [BSP/G]:	3/4" F	3/4" F
Outlet [BSP/G]:	1" F	1" F
Pump body material:	Cast Iron	Cast Iron
Impeller material:	Sintered Steel	Sintered Steel
Vanes material:	POM	POM
Ring material:	HNBR	HNBR
Gasket material:	NBR	NBR
Flow meter digits:	3	3
Flow meter typology:	Oscillating disc	Oscillating disc
Flow meter precision [%]:	±1	±1
Repeatability [%]:	0,2	0,2
Delivery Hose [material, ø, m, fittings]:	rubber, 20, 4, 1"x1"	rubber, 20, 4, 1"x1"
Nozzle:	automatic / manual	automatic / manual
Internal filter:	no	no
Motor support:	si	si
Min/max Temperature [°C]:	-20/+50	-20/+50
Max fluid viscosity [cSt] (a 40 °C):	2 ÷ 5	2 ÷ 5
Compatible fluids:	diesel	diesel
Not allowed fluids:	gas, alcohol, water, gasoline, kerosene	
Loudness at less 1 meter [dB]:	75	75
Net Weight [Kg]:	9.5	9.5
Gross Weight [Kg]:	10	10



Adam Pumps S.p.A.
 via della Resistenza 46/48
 41011 Campogalliano (MO) - ITALIA
 tel. +39 059 528 128 | fax +39 059 528 437
 info@adampumps.com | www.adampumps.com



vista esplosa - exploded view

DRUM TECH

MADE IN ITALY 

	CODE	DESCRIPTION	QTY
1	17001057D	Reduction 1" 3/4"	1
2	24000500000F	Telescopic pipe 3/4"	1
3	93500000000	Black terminal 26/32	1
4	240010000000	Pipe tightening ring nut TTM	1
5	17001102	filter 3/4" M	1
6	DT001	Drum tech holster	1
7	-	Nozzle	1
8	HT008	ROUGH TELEPHONE	1
9	OR011	O-RING 37 x 3 NBR	2
10	TUB190411	RUBBER HOSE	1
11	81282325100	Screw FR m6x20	2
12	VT005	Screw FR M8x1	2
14	18001008	O-Ring 3118 NBR	1
15	MA092	Meter faceplate	1
16	-	Electric pump	1
17	TF3S1	Meter	1
18	VT020	screw TE FR M8 x 30 DIN6921	

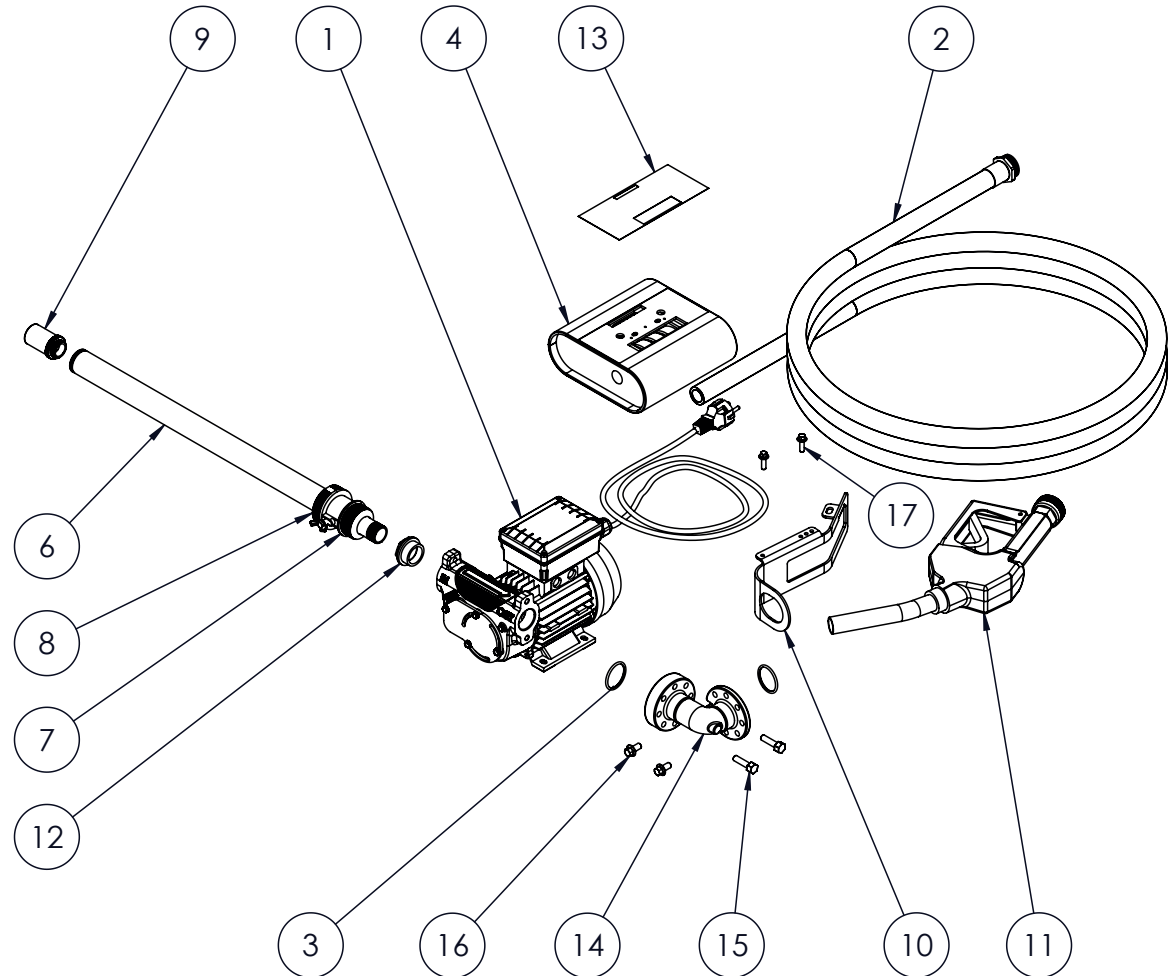

Adam Pumps S.p.A.
 via della Resistenza 46/48
 41011 Campogalliano (MO) - ITALIA
 tel. +39 059 528 128 | fax +39 059 528 437
 info@adampumps.com | www.adampumps.com



ingombri - overall dimensions

DRUM TECH 40

MADE IN ITALY 

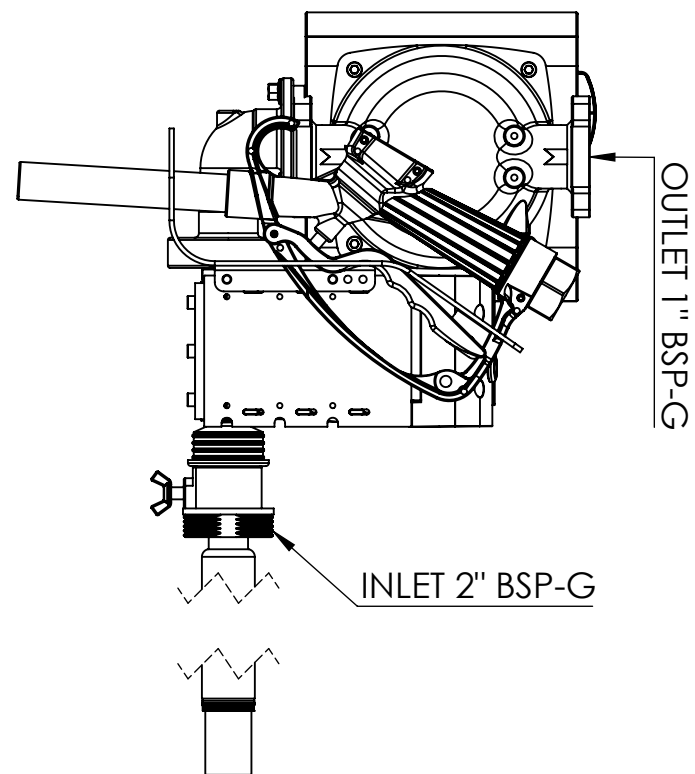
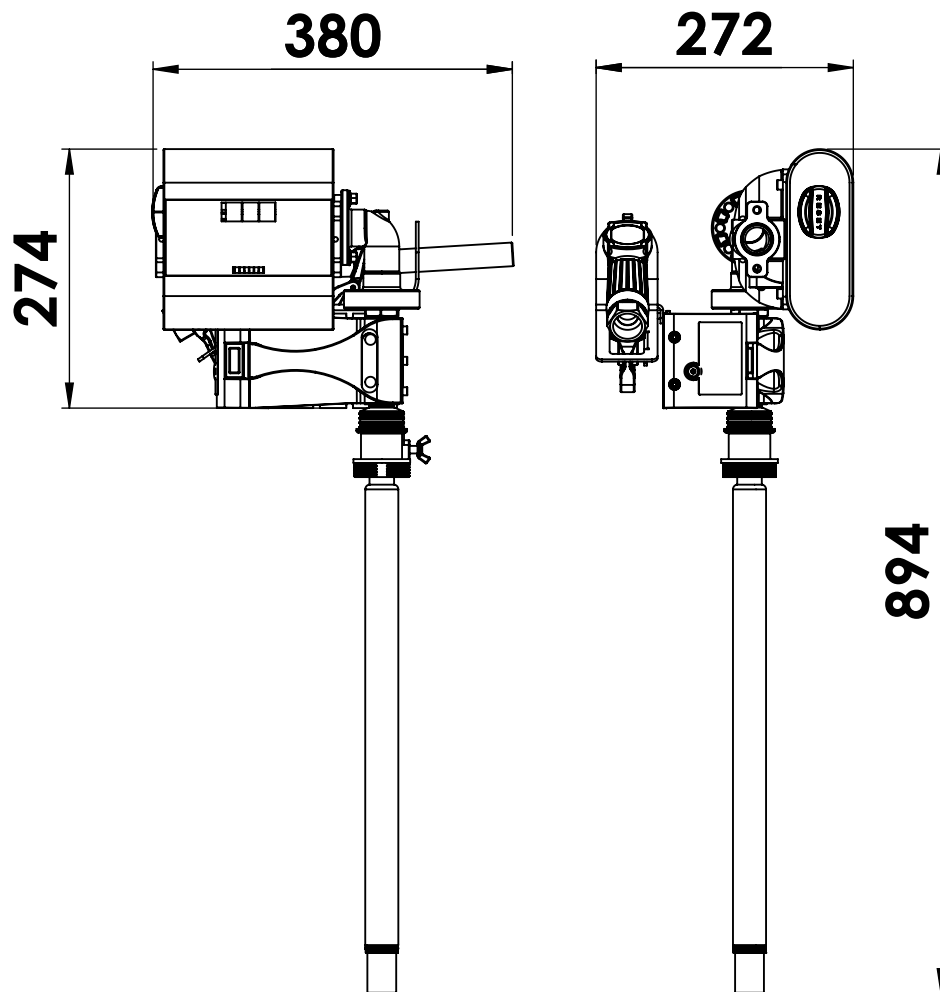

Adam Pumps S.p.A.
via della Resistenza 46/48
41011 Campogalliano (MO) - ITALIA
tel. +39 059 528 128 | fax +39 059 528 437
info@adampumps.com | www.adampumps.com

tutte le dimensioni espresse in mm - all dimensions are in mm



ingombri - overall dimensions

DRUM TECH 60

MADE IN ITALY 

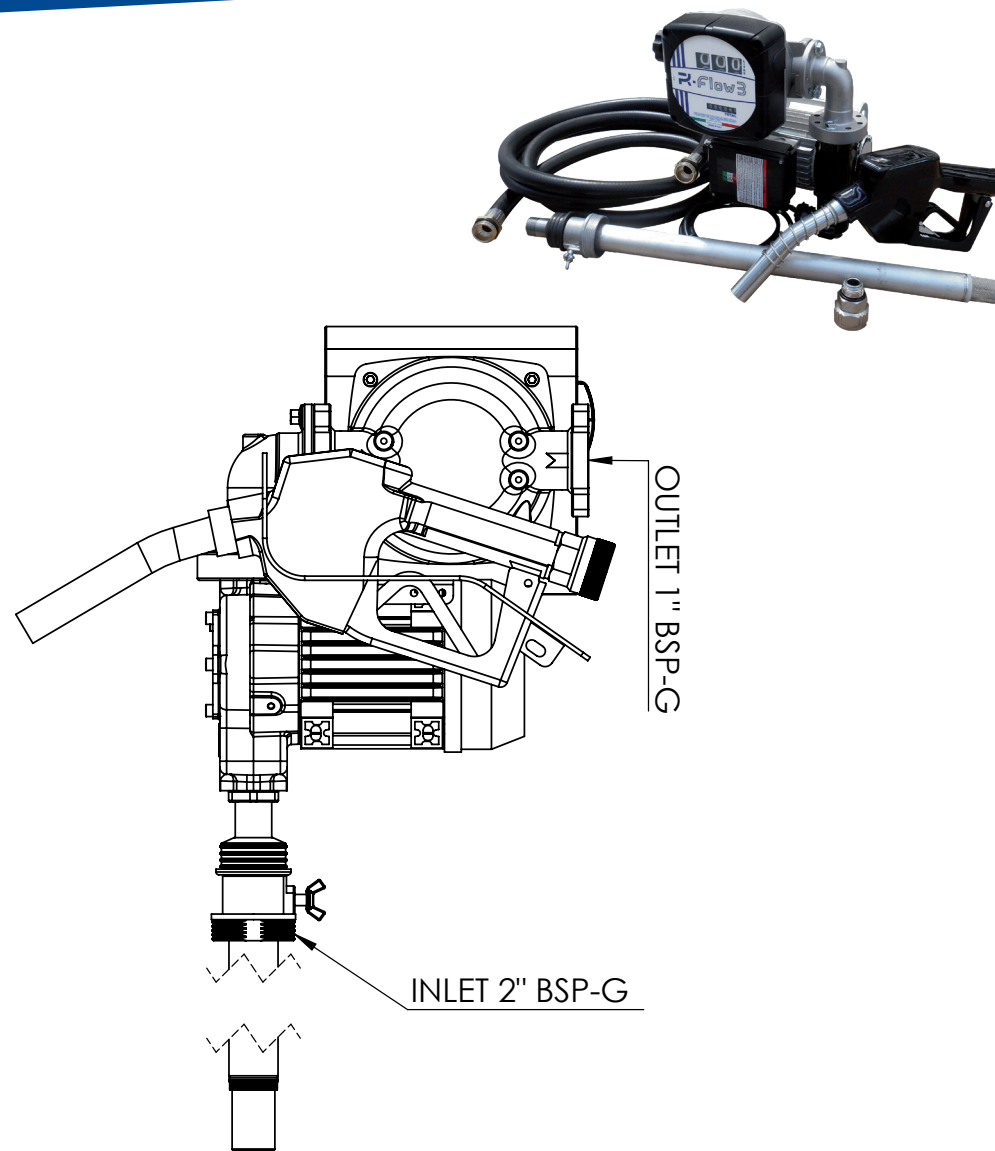
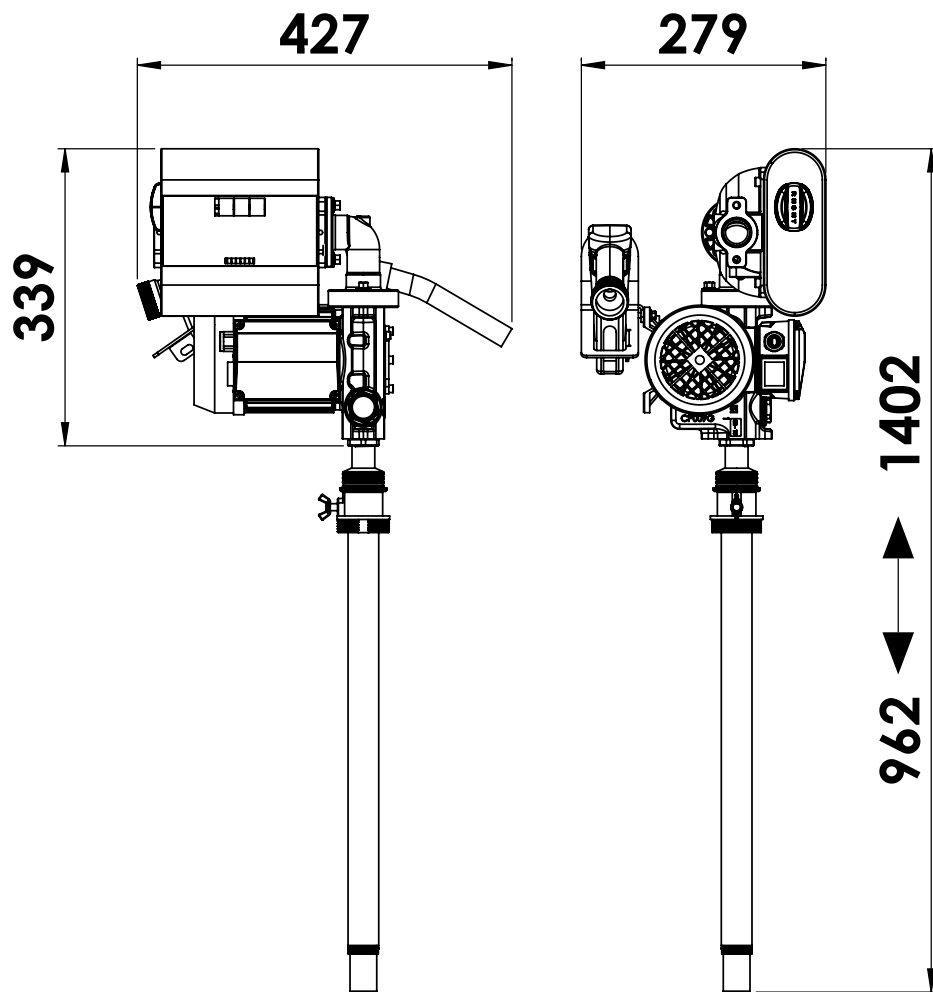

Adam Pumps S.p.A.
via della Resistenza 46/48
41011 Campogalliano (MO) - ITALIA
tel. +39 059 528 128 | fax +39 059 528 437
info@adampumps.com | www.adampumps.com

tutte le dimensioni espresse in mm - all dimensions are in mm



DRUM TECH DC 40-85

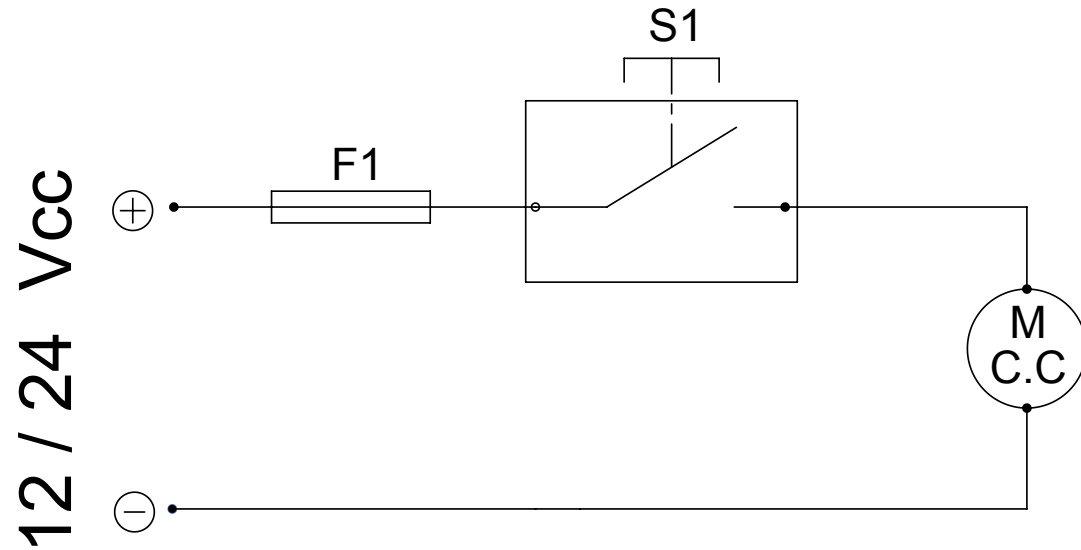

SCHEMA ELETTRICO



S:1 interruttore ON-OFF
 M: motore
 T: protezione termica
 R: raddrizzatore

WIRING DIAGRAM



S1: ON-OFF switch
 M: Motor
 T: Circuit Breaker
 R: Rectifier (in motor)

SCHALTPLÄNE



S1: ON - OFF Schalter
 M: Motor
 T: Temperaturschutz
 R: Gleichrichter

SCHÉMAS ÉLECTRIQUES



S1: interrupteur ON-OFF
 M: moteur
 T: protection Thermique
 R: Redresseur

ESQUEMAS ELÉCTRICOS



S1: interruptor ON-OFF
 M: motor
 T: protección térmica
 R: rectificador

ESQUEMAS ELÉCTRICOS



S1: Interruptor ON-OFF
 M: Motor
 T: Proteção Térmica
 R: retificador

ЭЛЕКТРИЧЕСКИЕ СХЕМЫ



S1: переключатель ВКЛ-ВЫКЛ
 M: Двигатель
 T: Термореле
 R: выпрямитель



DRUM TECH 60-100

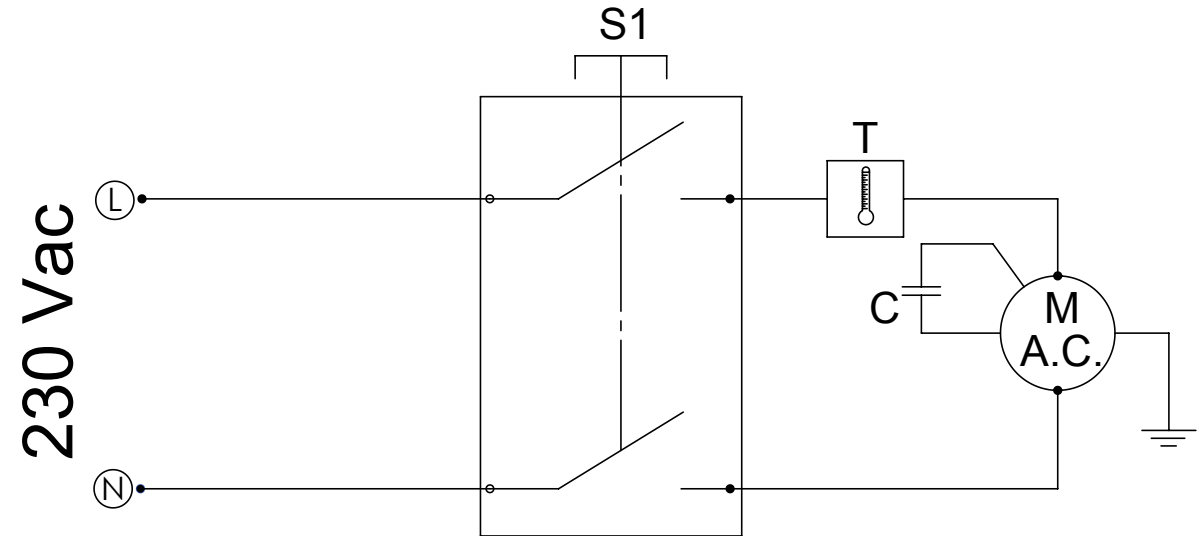

schema elettrico

wiring diagram

schaltpläne

schémas électriques

esquemas eléctricos

esquemas elétricos

электрические схемы

S:1 interruttore ON-OFF
M: motore
T: protezione termica
C: condensatore

S1: interruptor ON-OFF
M: motor
T: protección térmica
C: condensador

S1: ON-OFF switch
M: Motor
T: Circuit Breaker
C: Capacitor

S1: Interruptor ON-OFF
M: Motor
T: Proteção Térmica
C: condensador

S1: ON - OFF Schalter
M: Motor
T: Temperaturschutz
C: Kondensator

S1: переключатель ВКЛ-ВЫКЛ
M: Двигатель
T: Термореле
C: Конденсатор

S1: interrupteur ON-OFF
M: moteur
T: protection Thermique
C: condensateur

