

W. ROBINSON & SONS



PUMPS & PUMPING

CONTENTS

ACCESSORIES	206-209	LIFTING CHAIN	84
AD BLUE PUMPS	245	LOW VOLTAGE FUEL OIL	240-241
BALL RETAINING VALVES	211	LOW VOLTAGE MACERATOR	262
BILGE PUMPS	261-263	LOW VOLTAGE SUBMERSIBLES	261
BOOSTER PUMPS	159-171	LOW VOLTAGE SURFACE PUMPS	252, 255, 262-263
BOREHOLE MOTORS	231	MACHINE TOOL SUDS PUMPS	267
BOREHOLE PUMPS	224-235	MONO PUMPS	257
BRASSWARE	207-209	MULTISTAGE HORIZONTAL	148, 150-152, 154-158
CAPACITORS	236	MULTISTAGE SUBMERSIBLE	220-235
CAM COUPLINGS	212-215	MULTISTAGE VERTICAL	153, 182-195
CHEMICAL PUMPS	40, 249-251	PATAY PUMPS	251
CONTROL PANELS	78-83	PERIPHERAL PUMPS	142
DIAPHRAGM PUMPS – ELECTRIC	252	PIPE FITTINGS	206-216
DIAPHRAGM PUMPS – ENGINE	114-115	POND DUTY PUMPS	3-5, 8, 19, 279
DIESEL FUEL PUMPS	113, 138-141, 238-259	PRESS CONTROL DEVICES	264-265
DIESEL ENGINE POWERED PUMPS	104-115	PRESSURE SETS	159-171
DOMESTIC PUMPS	278-283	PRESSURE SWITCHES & GAUGES	197, 199
DRAINAGE PUMPS	2-25	PRESSURE VESSELS	200-205
DRAINAGE (HEAVY DUTY)	10-77	RESIDUE PUMPS	12-15, 280
DRENO PUMPS	44-77	SAND PUMPS (QUARRY)	40-43
DRUM PUMPS	241, 249, 251	SELF PRIMING CONTRACTOR PUMPS	125-141
ELECTRIC MOTORS	286-287	SELF PRIMING JET PUMPS	144-149
END SUCTION PUMPS	174-181	SELF PRIMING REVERSING PUMPS	253
ENGINES – REPLACEMENT	272-275	SEWAGE INDUSTRIAL	26-77
ENGINE PUMPS	100-117	SEWAGE PACKAGE STATIONS	96-99
EXPLOSION PROOF PUMPS ATEX	49-77, 140-141	SEWAGE PUMPS	5-7, 10-11, 26-77
FLOAT SWITCHES	85-91	SHOWER PUMPS	288
FOUNTAIN HEADS & PUMPS	279	STAINLESS STEEL SUBMERSIBLE PUMPS	3-7, 21, 34-35
FUEL OIL PUMPS	138-141, 238-259	STUART TURNER PUMPS	288
FUEL OIL DISPENSING KITS	239-241	SUCTION HOSE	119-121
FUEL OIL ACCESSORIES	246-247	SWIMMING POOL PUMPS	276-277, 283
GARDEN PUMPS	278-283	TOILET WASTE UNITS	95
GEAR PUMPS	244, 256, 263	VALVES & FITTINGS	206-216
GENERATORS PETROL	269-271	VARIABLE SPEED DRIVES	172-173
GENERATORS INVERTER	269	VARIABLE SPEED PUMPS	168-171
GRINDER PUMPS	32-34, 37, 74-77	VERTICAL SUMP PUMPS	266
HAND PUMPS	248-251	VILLAGE HAND PUMPS	278
HONDA POWERED ENGINE PUMPS	101, 106-107, 112-114	WASTE WATER PACKAGE SETS	92-99
HOSE FITTINGS	206-216	WATER FILTERS	260
JABSCO UTILITY	250	WELL PUMPS	220-235
KIOSK	84	WRAS APPROVED PUMPS	154-158, 182-187
LAYFLAT HOSE	122-124	WRAS APPROVED VESSELS	201, 203

SUBMERSIBLE PUMPS

ABS ROBUSTA

E

The Robusta 200 and 300 series have been designed for fixed or portable installation and for internal or external applications such as emptying containers, drainage pits, draining of swimming pools or flooded cellars. Robusta is fitted with an automatic level control. The Hand-Auto switch can be set to manual operation. A check valve built into the discharge outlet blocks return-flow from the discharge line when the pump is switched off. 10m power cable. 1 1/4" bsp reducing hose adapter - 1" hose - 3/4" bsp - 3/4" hose

Features

Max Solids 10mm
Built In Non Return Valve

Applications

Clean & Dirty Water
Residue Water

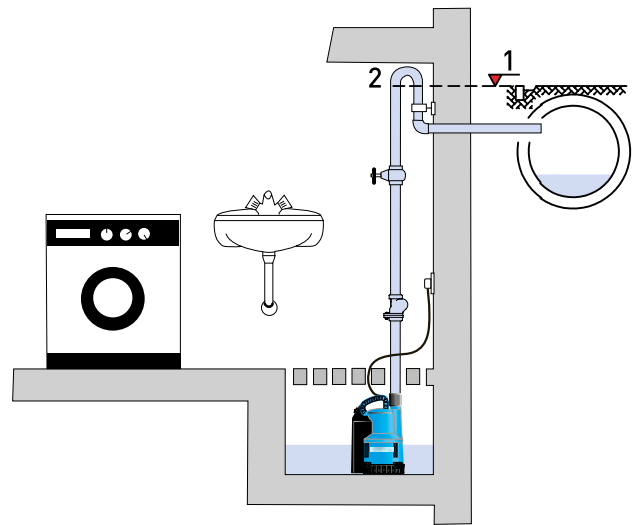
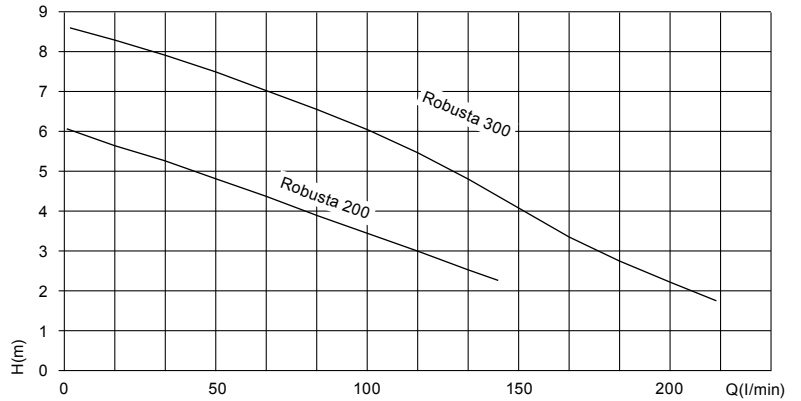

1. Backwash level
2. Backwash loop with base above the backwash level

Auto Switching Levels

Robusta 200

On At 145mm / Off At 50mm

Robusta 300

On At 165mm / Off At 75mm

MODEL	VOLT	OUTLET	LM/HM	Kw	AMP	H x W x L mm	Kg	CODE
ROBUSTA 200	230v	1 1/4"	140/6	0.36	1.6	304 x 157 x 195	3.8	020-785
ROBUSTA 300	230v	1 1/4"	215/8.5	0.5	2.2	324 x 157 x 195	4.4	020-788

SUBMERSIBLE PUMPS

CK SERIES STAINLESS STEEL

A

CK series are submersible centrifugal drainage pumps. Supplied with 10 metres of power cable. Twin mechanical seals in a lubricated chamber. For use in drainage, clean, black water and circulation duties. Maximum submersion depth 5 metres. Maximum liquid temperature 50°C. Solids handling of 10mm. CK45 model complete with non return valve. All models are supplied with hose tails.

Features

- S/Steel Pump Body
- S/Steel Impeller
- Max Solids 10mm

Applications

- Clean Water
- Black Water
- Dirty Water

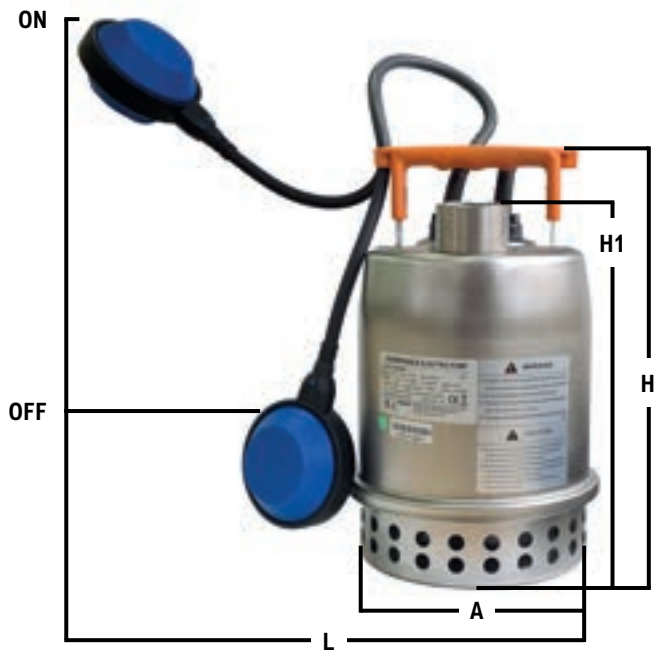
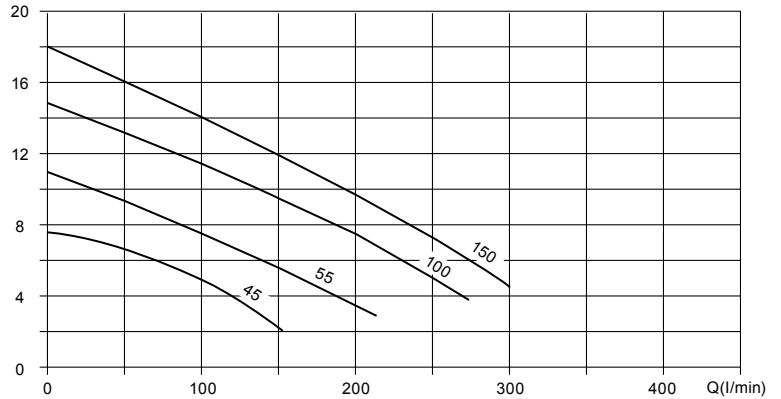

Model	H	H1	L	A	ON (Approx)	OFF (Approx)
CK 45MA	273	231	380	167	320	80
CK 55MA	360	324	485	211	400	120
CK 100MA	360	324	485	211	400	120
CK 150MA	375	339	500	211	400	120

MODEL	VOLT	OUTLET	LM/HM	Kw	AMP	H x W x L mm	Kg	CODE
CK 45MA	230v	1¼"	150/7.5	0.25	1.9	273 x 167 x 167	5.5	9000-2130
CK 55MA	230v	1½"	216/11	0.37	2.4	360 x 211 x 211	9.6	9000-2135
CK 100MA	230v	1½"	275/15	0.75	5.2	360 x 211 x 211	12	9000-2145
CK 150MA	230v	1½"	300/18	1.1	7.0	375 x 211 x 211	13	9000-2150

SUBMERSIBLE PUMPS

(NOCCHI)

PENTAIR JUNG DRENOX

E

Drenox range are centrifugal drainage pumps. All stainless steel. Supplied with 10 metres of power cable and hose tail. Twin oil sealed motor. For use in drainage, clean, black water and circulation duties. Maximum submersion depth 7 metres. Maximum liquid temperature 40°C.

Features

- S/Steel Pump Body
- S/Steel Impeller
- Max Solids 6mm

Applications

- Clean Water
- Black Water
- Dirty Water

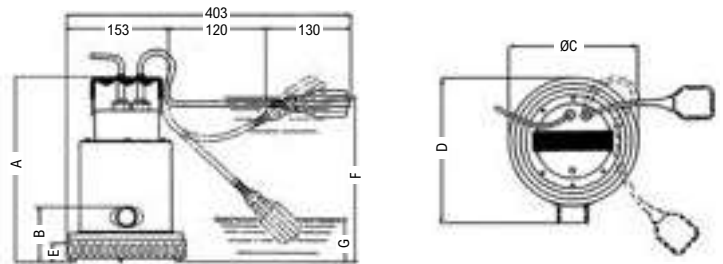
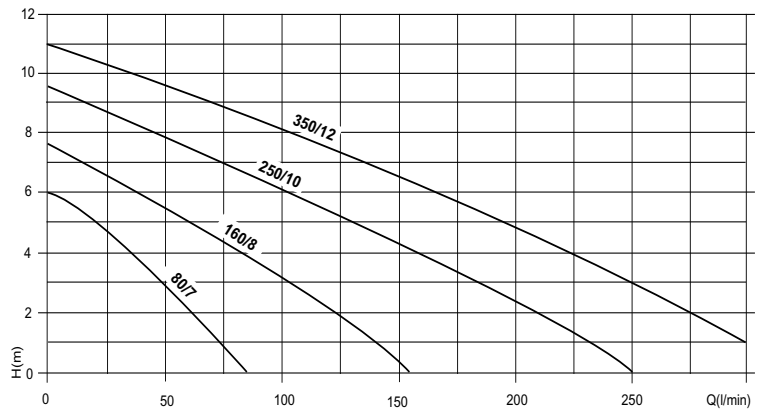

Model	A	B	C	D	F ON LEVEL	G OFF LEVEL
DRENOX 80/7	260	94	177	182		
DRENOX 80/7A	260	94	177	182	250	100
DRENOX 160/8	300	94	177	182		
DRENOX 160/8A	300	94	177	182	320	107
DRENOX 250/10	338	94	177	182		
DRENOX 250/10A	338	94	177	182	351	111
DRENOX 350/12	338	94	177	182		
DRENOX 350/12A	338	94	177	182	351	111

MODEL	VOLT	OUTLET	Kw	AMP	LM/HM	H x W x L mm	Kg	CODE
80-7 MANUAL	110v	1¼"	0.2	2.2	80/6	260 x 177 x 182	5.7	555-001
80-7 AUTO	110v	1¼"	0.2	2.2	80/6	260 x 177 x 182	5.7	555-006
80-7 MANUAL	230v	1¼"	0.2	1.3	80/6	260 x 177 x 182	5.7	555-003
80-7 AUTO	230v	1¼"	0.2	1.3	80/6	260 x 177 x 182	5.7	555-009
160-8 MANUAL	230v	1¼"	0.4	2.4	150/7.5	300 x 177 x 182	6.5	555-012
160-8 AUTO	230v	1¼"	0.4	2.4	150/7.5	300 x 177 x 182	6.5	555-015
250-10 MANUAL	230v	1¼"	0.55	4.5	250/9.5	338 x 177 x 182	7.0	555-017
250-10 AUTO	230v	1¼"	0.55	4.5	250/9.5	338 x 177 x 182	7.0	555-022
350-12 MANUAL	230v	1¼"	0.8	5.1	350/11	338 x 177 x 182	8.5	555-025
350-12 AUTO	230v	1¼"	0.8	5.1	350/11	338 x 177 x 182	8.5	555-028
350-12 MANUAL	400v	1¼"	0.8	2.0	350/11	338 x 177 x 182	8.5	555-029

SUBMERSIBLE PUMPS

(NOCCHI)

PENTAIR JUNG OMNIA

E

Omnia range are vortex pumps. All stainless steel. Supplied with 10 metres of power cable and hose tail. Twin oil sealed motor. For use in drainage, black water, cess pits, pond circulation and where soft solids in the water are no bigger than 20mm. Maximum submersion depth 7 metres. Maximum liquid temperature 40°C.

Features

- S/Steel Pump Body
- S/Steel Impeller
- Max Solids 20mm

Applications

- Clean Water
- Black Water
- Dirty Water

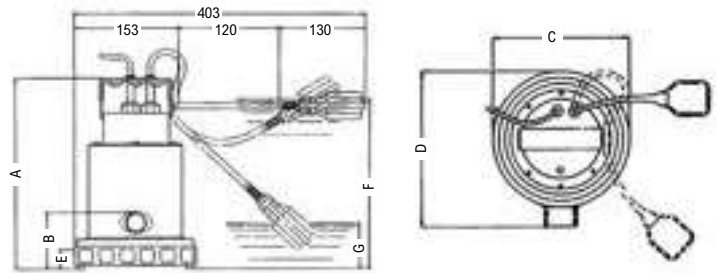
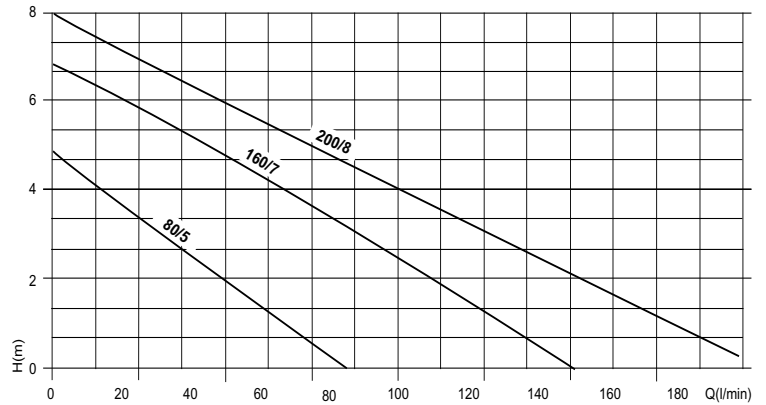

Model	A	B	C	D	E	F	G
OMNIA 80/5	264	94	177	182	32		
OMNIA 80/5A	264	94	177	182	35	250	100
OMNIA 160/7	300	94	177	182	35		
OMNIA 160/7A	300	94	177	182	35	320	107
OMNIA 200/8	338	94	177	182	35		
OMNIA 200/8A	338	94	177	182	35	351	111

MODEL	VOLT	OUTLET	LM/HM	Kw	AMP	H x W x L mm	Kg	CODE
80-5 MAN	110v	1¼"	80/5	0.2	1.4	264 x 177 x 182	6.1	555-041
80-5 AUTO	110v	1¼"	80/5	0.2	1.4	264 x 177 x 182	6.1	555-035
80-5 MAN	230v	1¼"	80/5	0.2	2.8	264 x 177 x 182	6.1	555-031
80-5 AUTO	230v	1¼"	80/5	0.2	2.8	264 x 177 x 182	6.1	555-033
160-7 MAN	230v	1¼"	150/6.5	0.37	2.5	300 x 177 x 182	7.0	555-037
160-7 AUTO	230v	1¼"	150/6.5	0.37	2.5	300 x 177 x 182	7.0	555-039
200-8 MAN	230v	1¼"	200/8	0.5	3.2	338 x 177 x 182	8.5	555-043
200-8 AUTO	230v	1¼"	200/8	0.5	3.2	338 x 177 x 182	8.5	555-045
200-8 MAN	110v	1¼"	200/8	0.5	6.4	338 x 177 x 182	8.5	555-050
200-8 AUTO	110v	1¼"	200/8	0.5	6.4	338 x 177 x 182	8.5	555-048

SUBMERSIBLE PUMPS

(NOCCHI)

PENTAIR JUNG BIOX

E

Biox range is an all stainless steel pump used for the pumping of waste water containing soft solids up to 40mm. Silicon carbide seal followed by oil lip seal. Supplied with 10 metres of power cable. No hose tail is supplied. Maximum submersion depth 7 metres. Maximum liquid temperature 40°C.

Features

- S/Steel Pump Body
- S/Steel Impeller
- Max Solids 40mm

Applications

- Suspended Solids
- Cess Pits
- Dirty Water
- Discharge Water (Toilets)

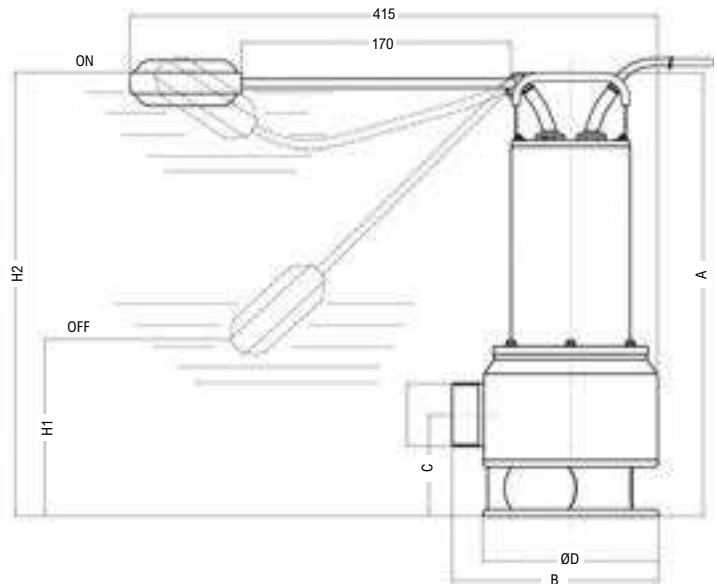
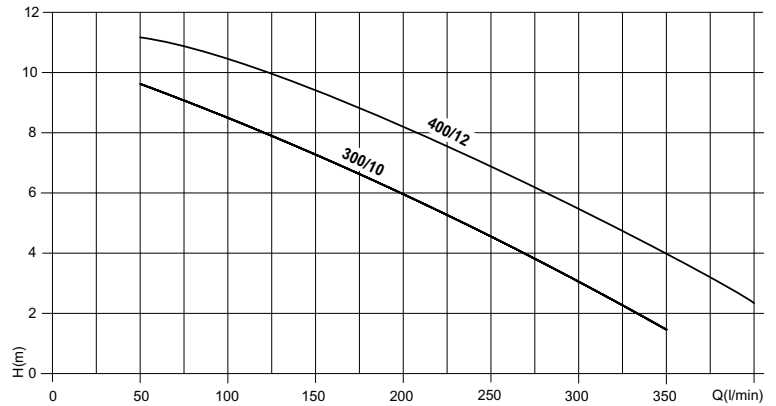

Model	A	B	C	D	H1	H2
BIOX 300/10A	419	196	96	168	300	400
BIOX 400/12A	419	196	96	168	300	400

MODEL	VOLT	OUTLET	LM/HM	kW	AMP	H x W x L mm	Kg	CODE
BIOX 300-10 AUTO	230v	2"	350/11	1.3	5.8	419 x 168 x 196	10	555-054
BIOX 400-12 AUTO	230v	2"	450/12	1.6	7.2	419 x 168 x 196	11	555-057

SUBMERSIBLE PUMPS

(NOCCHI)

PENTAIR JUNG PRIOX

E

Priox range are an all stainless steel pump. They operate entirely immersed in the pumped liquid, which serves to cool the motor. Used for pumping sewage water, emptying of cess pits with free passage of solids. Silicon carbide mechanical seal and oil sealed motor. Supplied with ten metres of power cable. Maximum submersion depth seven metres. No hose tail supplied. Maximum liquid temperature 40°C.

Features

- S/Steel Pump Body
- S/Steel Impeller
- Max Solids 420/460 40mm
- 600/800 50mm

Applications

- Suspended Solids
- Cess Pits
- Dirty Water
- Discharge Water (Toilets)

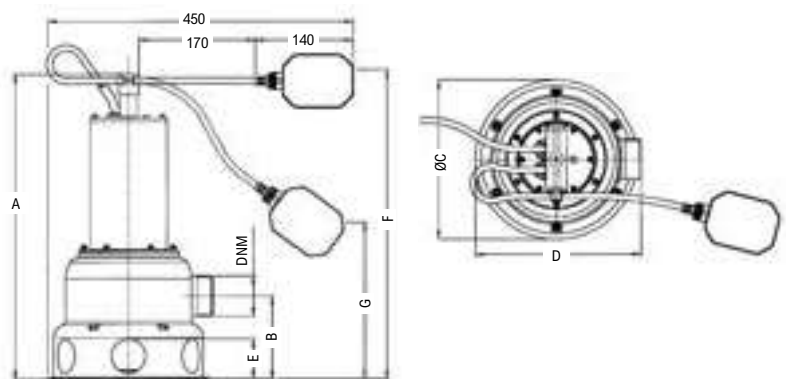
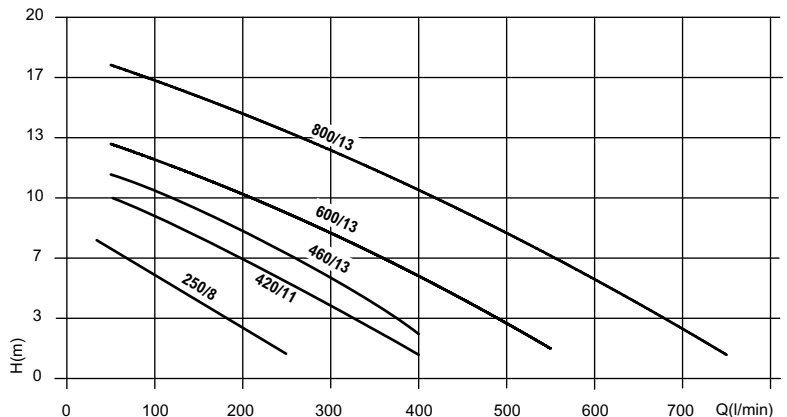

Model	A	B	C	D	F ON LEVEL	G OFF LEVEL
PRIOX 250/8A	420	122.5	235	249	550	290
PRIOX 420/11	450	122.5	235	249		
PRIOX 420/11A	450	122.5	235	249	550	290
PRIOX 460/13	450	122.5	235	249		
PRIOX 460/13A	450	122.5	235	249	580	320
PRIOX 600/13	450	122.5	235	249		
PRIOX 800/18	485	122.5	235	249		

MODEL	VOLT	OUTLET	LM/HM	Kw	AMP	H x W x L mm	Kg	CODE
250/8 AUTO	230v	1½"	250/8	0.8	3.6	420 x 235 x 249	9.4	555-061
420-11 MANUAL	230v	2"	420/11	0.9	6	450 x 235 x 249	11.2	555-065
420-11 AUTO	230v	2"	420/11	0.9	6	450 x 235 x 249	11.2	555-064
420-11 MANUAL	400v	2"	420/11	0.9	2.3	450 x 235 x 249	11.2	555-063
460/13 MANUAL	230v	2"	460/13	1.1	7.2	450 x 235 x 249	11.7	555-062
460/13 AUTO	230v	2"	460/13	1.1	7.2	450 x 235 x 249	11.7	555-066
460/13 MANUAL	400v	2"	460/13	1.1	7.2	450 x 235 x 249	11.7	555-067
600/13 MANUAL	400v	2"	600/13	1.2	3.1	450 x 235 x 249	12.6	555-068
800/18 MANUAL	400v	2"	800/18	2.4	5.5	485 x 235 x 249	20.2	555-069

SUBMERSIBLE PUMPS

PENTAIR FLOTEC VIP & VIPVORT

E

Vip series are for clean and dirty water applications, emptying of cellars, rain water collection tanks. Vipvort are for dirty water with suspended solids up to 20mm. Both versions have the following - Pump body, diffuser and strainer made from polypropylene, stainless steel motor housing and shaft. Shaft with ceramic sleeve at wear point and double oil seals. All models come with ten metres of power cable and hose tail. Maximum immersion 7 metres. Maximum liquid temperature 40°C.

Features

- Polypropylene Pump Body
- Noryl Impeller
- Max Solids Vip 5mm
- Vipvort 20mm

Applications

- Suspended Solids
- Cess Pits
- Dirty Water

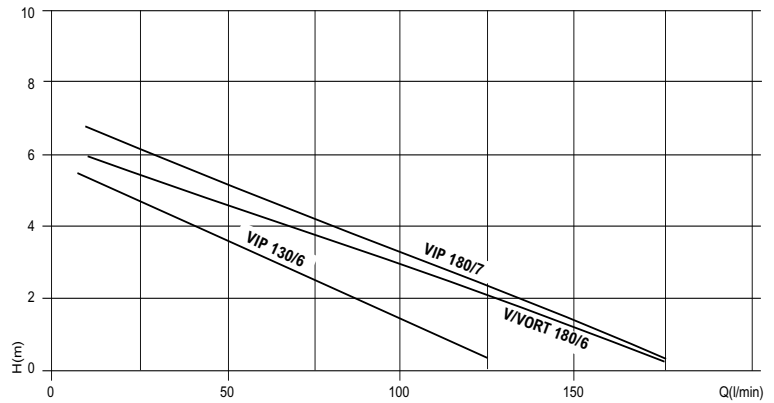

VIP 130-6



VIPVORT 130-6



MODEL	VOLT	OUTLET	LM/HM	Kw	AMP	H x W x L mm	Kg	CODE
VIP 130-6 MANUAL	230v	1¼"	130/6	0.32	1.4	295 x 165 x 170	4.1	020-070
VIP 130-6 AUTO	230v	1¼"	130/6	0.32	1.4	295 x 165 x 170	4.1	020-072
VIP 180-7 AUTO	230v	1¼"	180/7	0.37	2.1	295 x 165 x 170	4.5	020-076
VIPVORT 180-6 AUTO	230v	1¼"	180/6	0.48	2.1	300 x 165 x 170	4.5	020-086

SUBMERSIBLE PUMPS

JS RS100

A

Light duty centrifugal drainage pump, suitable for clean and dirty water. Not suitable for continuous pond usage. Designed for small sumps. Can be made to work automatically by fitting either the small Key Mac-3 or Agma float. Top outlet. Plastic outer cover, lower motor/bearing housing, impeller, pump housing and strainer. These pumps are not to be installed laying on their sides. Complete with 1" female hose tail and 10 metre power cable.

Features

- Plastic Pump Body
- Plastic Impeller
- Max Solids 4mm

Applications

- Light Duty Drainage
- Clean Water
- Dirty Water
- Tanks

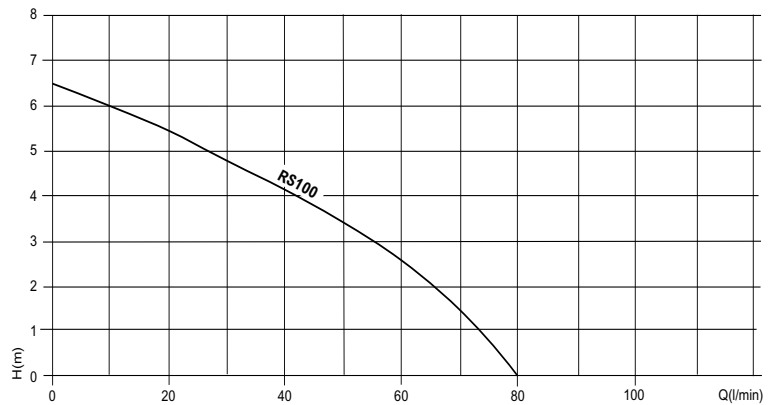

RS 100 110v



RS 100 230v



RS 100 SHOWN WITH AGMA



RS 100 SHOWN WITH SMALL MAC3

MODEL	VOLT	OUTLET	LM/HM	Kw	AMP	H x W x L mm	Kg	CODE
RS100	230v	1"	80/6.5	0.1	1	260 x 132 x 132	4.7	010-100
RS100	110v	1"	80/6.5	0.1	2	260 x 132 x 132	4.7	010-102

MODELS JS/RS

CAN BE MODIFIED FOR AUTOMATIC OPERATION

A

TYPE	CODE
FLOAT SWITCH – MAC3	020-001
FLOAT SWITCH – AGMA 22 MAGNETIC	020-003



MAC3



AGMA

SUBMERSIBLE PUMPS

JS150SV

A

JS150SV vortex impeller, capable of pumping soft solids up to 25mm. Plastic motor lid, lower motor/bearing housing, impeller and pump body. Single silicon mechanical seal. 10 metres of power cable. 1¼" BSP female outlet, complete with 1¼" male hose tail. The JS150SV pumps must not be installed laying on their side. Maximum immersion 7 metres.

Features

- Plastic Pump Body
- Plastic Impeller
- Max Solids **25mm**

Applications

- Light Duty Sewage
- Clean Water
- Dirty Water

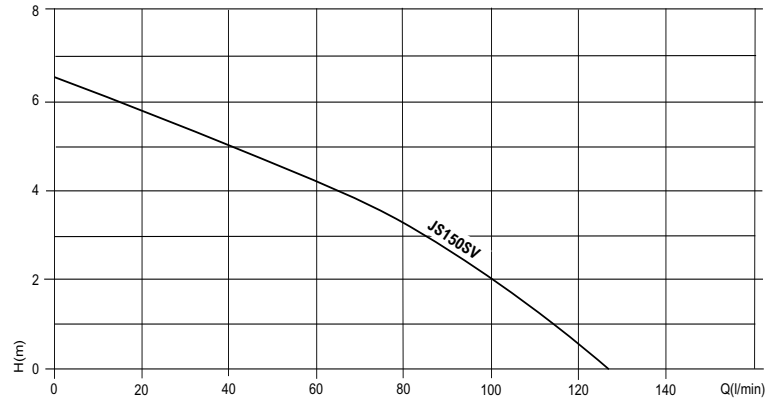
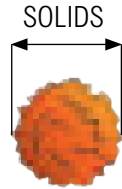

**JS-150SV
MANUAL**



**JS-150SVA
MAC-3**



**JS-150SVAG
AGMA**

MODEL	VOLT	OUTLET	LM/HM	Kw	AMP	H x W x L mm	Kg	CODE
JS-150 SV MANUAL	230v	1¼"	125/6.5	0.15	1.4	330 x 137 x 178	5.5	011-150
JS-150 SVA KEY MAC-3	230v	1¼"	125/6.5	0.15	1.4	330 x 137 x 178	5.7	011-150A
JS-150 SVAG AGMA	230v	1¼"	125/6.5	0.15	1.4	330 x 137 x 200	5.7	011-150AG
JS-150 SV MANUAL	110v	1¼"	125/6.5	0.15	2.8	330 x 137 x 178	5.5	011-152
JS-150 SVA KEY MAC-3	110v	1¼"	125/6.5	0.15	2.8	330 x 137 x 178	5.7	011-152A
JS-150 SVAG AGMA	110v	1¼"	125/6.5	0.15	2.8	330 x 137 x 200	5.7	011-152AG

SUBMERSIBLE PUMPS

JS250SV

A

JS250SV vortex impeller, capable of pumping soft solids up to 36mm. Cast iron motor lid, lower motor/seal housing and pump chamber. Stainless steel shaft and outer motor casing. Twin mechanical seals in a lubricated chamber. 10 metres of power cable. 1½" BSP female outlet, complete with 1½" BSP male hose tail. Maximum immersion 7 metres. JS250SV can be fitted to the SR50 coupling foot and claw. See page 30 for dimensions.

Features

Cast Iron Pump Body
Plastic Impeller
Max Solids **36mm**

Applications

Light Duty Sewage
Clean Water
Dirty Water

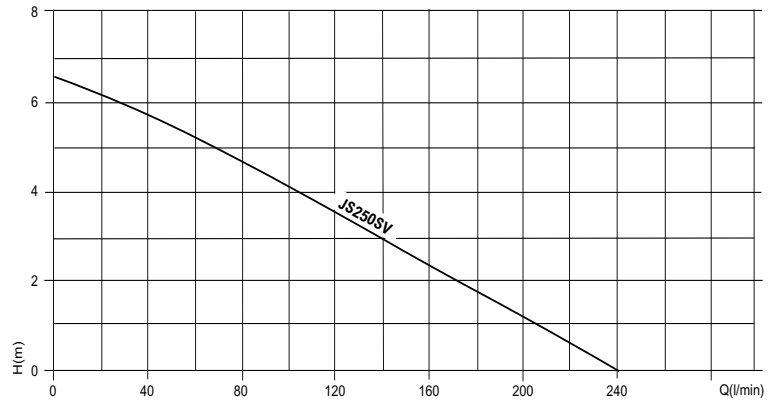
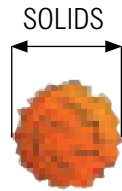

**JS-250SV
MANUAL**



**JS-250SVA
MAC-3**



**JS-250SVAG
AGMA**

MODEL	VOLT	OUTLET	LM/HM	Kw	AMP	H x W x L mm	Kg	CODE
JS-250 SV MANUAL	230v	1½"	240/6.5	0.25	1.9	415 x 160 x 260	15	011-250
JS-250 SVA MAC-3	230v	1½"	240/6.5	0.25	1.9	415 x 160 x 260	15	011-250A
JS-250 SVAG AGMA	230v	1½"	240/6.5	0.25	1.9	415 x 215 x 260	15	011-250AG
JS-250 SV MANUAL	110v	1½"	240/6.5	0.25	4.0	415 x 160 x 260	15	011-252
JS-250 SVA MAC-3	110v	1½"	240/6.5	0.25	4.0	415 x 160 x 260	15	011-252A
JS-250 SVAG AGMA	110v	1½"	240/6.5	0.25	4.0	415 x 215 x 260	15	011-252AG

SUBMERSIBLE PUMPS

PUDDLE BUDDY RESIDUE PUMP

A

The Puddle Buddy pump is an all-round semi-professional residue pump, designed for clean water in domestic applications - flooded rooms, garages and cellars. Will start pumping at approx 2mm water level. One inch male top outlet complete with 1" / 3/4" / 1/2" step adapter female hose tail. Single mechanical seal and oil seal. Complete with 10 metres of power cable and anti air lock valve especially useful when using in shallow water. These pumps must not be installed/left laying on their side. Low level control see pages 90 & 91.

Features

- Plastic Pump Body
- Plastic Impeller
- Max Solids 1mm

Applications

- Domestic Duty / Light Commercial
- Clean Water
- Residue Water
- Nuisance Water

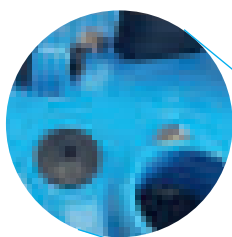
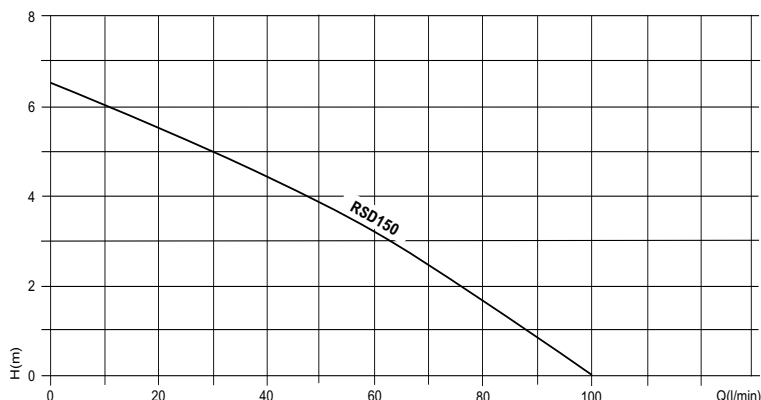

Anti-airlock device



RSD 150 SHOWN WITH THE CRAB LOW LEVEL SENSOR



MODEL	VOLT	OUTLET	LM/HM	Kw	AMP	H x W x L mm	Kg	CODE
RSD150	230v	1"	100/6.5	0.15	1.4	265 x 138 x 138	5	012-150
RSD150A-CRAB	230v	1"	100/6.5	0.15	1.4	265 x 138 x --	5.3	012-150A-CRAB
RSD150	110v	1"	100/6.5	0.15	3.0	265 x 138 x 138	5	012-152
RSD150-A-CRAB	110v	1"	100/6.5	0.15	3.0	265 x 138 x --	5.3	012-152A-CRAB

SUBMERSIBLE PUMPS

(NOCCHI)

PENTAIR FLOTEC COMPAC

E

The Compac range are for clean water, designed to drain domestic applications and ideal for limited spaces. Complete with integral float switch, which can be selected in automatic or manual mode. In automatic mode the pump switches on when the water level reaches approx 140mm and switches off at approx 30mm. In manual mode the level of water can be pumped down to approx 3mm. Supplied with check valve and a 1¼" adjustable hose connector for hose sizes ¾" 1" & 1¼". Complete with 10 metres of power cable. For low level control see page 90.

Features

- Polypropylene Pump Body
- Noryl Impeller
- Max Solids 5mm

Applications

- Domestic Duty / Light Commercial
- Clean Water
- Residue Water
- Nuisance Water

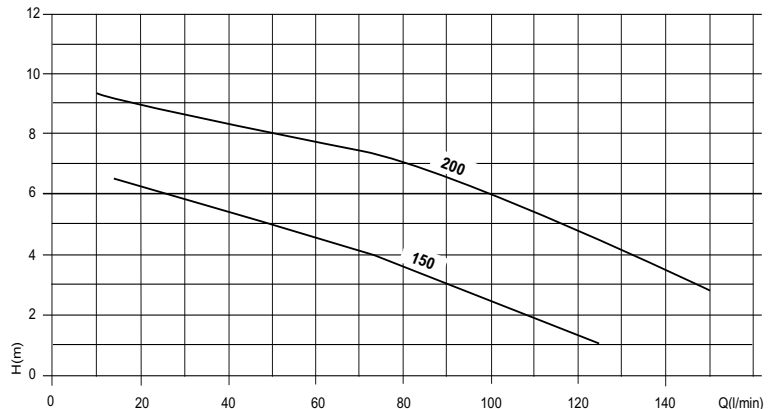

Automatic and manual code.



Integrated automatic floating switch. Draining level: 3mm with manual mode.

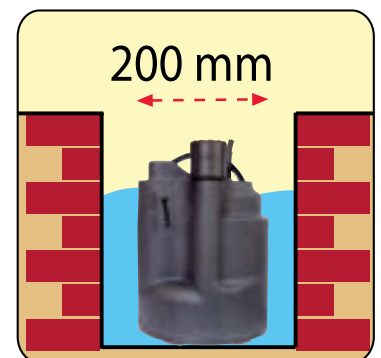

Ideal for limited space.

MODEL	VOLT	OUTLET	LM/HM	Kw	AMP	H x W x L mm	Kg	CODE
COMPAC 150	230v	1¼"	140/7	0.3	1.5	280 x 170 x 200	4.7	020-090
COMPAC 150	110v	1¼"	140/7	0.3	2.7	280 x 170 x 200	4.7	020-092
COMPAC 200 (DPC200)	230v	1¼"	190/10	0.65	2.9	280 x 170 x 200	5.6	020-094

SUBMERSIBLE PUMPS

KOSHIN PONSTAR PXL PROFESSIONAL RESIDUE DRAINAGE PUMP

A

PXL the professional puddle sucker pump that can drain down to approximately 1mm while the remaining flood water can be swept into the pump for removal. Mostly of an alloy construction. Twin mechanical seals in a lubricated chamber. Equipped with non return valve on the suction end of the pump to stop any return of water and has to be primed if using in shallow water. 1" Outlet flange that can be altered from vertical to horizontal to avoid kinks in the hose. Hose tail supplied. Complete with 10 metres of power cable. Can be used with electronic control for automatic operation see pages 90 & 91.

Features

Polyurethane Rubber Pump Body
 Polyurethane Impeller
 Max Solids 3mm

Applications

Heavy Duty
 Clean Water
 Drainage
 Nuisance Water

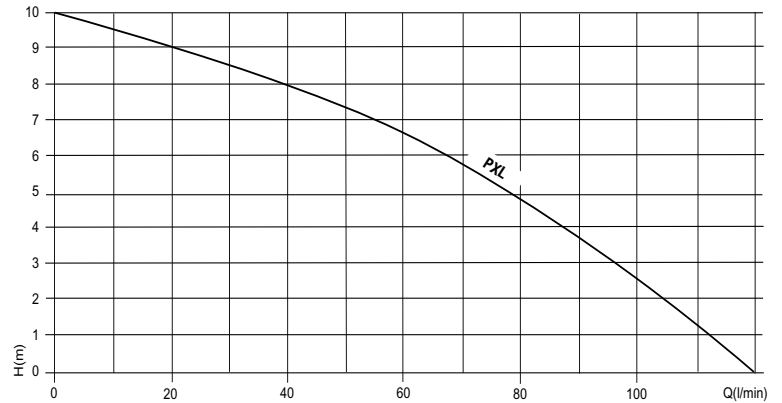

MODEL	VOLT	OUTLET	LM/HM	Kw	AMP	H x W x L mm	Kg	CODE
PONSTAR PXL 52522	230v	1"	120/10	0.54	2.9	315 x 190 x 190	13	PXL-52522
PONSTAR PXL 52511	110v	1"	120/10	0.59	6.0	315 x 190 x 190	13	PXL-52511

SUBMERSIBLE PUMPS

RSD-400 PROFESSIONAL RESIDUE DRAINAGE PUMP

A

RSD-400 the professional puddle sucker pump that can drain down to approximately 1mm while the remaining flood water can be swept into the pump for removal. Stainless steel outer case, motor and shaft. Twin mechanical seals in a lubricated chamber. Equipped with non return valve on the suction end of the pump to stop any return of water and has to be primed if using in shallow water. Bottom plate made with a cushioned rubber. 1¼" Outlet with 25mm, 19mm and 15mm step adapter hose tail. Complete with 10 metres of power cable. Can be used with electronic control for automatic operation see pages 90 & 91.

Features

Cast Iron Pump Body
Plastic Impeller
Max Solids 2mm

Applications

Heavy Duty
Clean Water
Drainage
Nuisance Water

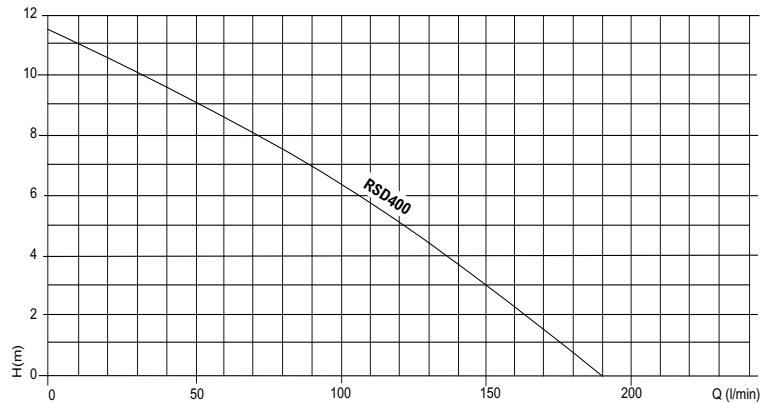

MODEL	VOLT	OUTLET	LM/HM	Kw	AMP	H x W x L mm	Kg	CODE
RSD-400	230v	1¼"	190/11.5	0.4	2.8	370 x 167 x 167	14	012-400
RSD-400	110v	1¼"	190/11.5	0.4	5.6	370 x 167 x 167	14	012-402

SUBMERSIBLE PUMPS

KOSHIN PONSTAR PX

A

Suitable for heavy duty applications in clean and dirty water, twin mechanical seals, one carbon and one silicon in a lubricated chamber. Mostly of an alloy construction. Impeller and volute plate are coated with a polyurethane for a longer life than traditional cast iron. Complete with 10m of power cable, hose tail and 5 metres of lifting rope. Designed so that the delivery flange can be changed from vertical to horizontal to stop the hose kinking over.

Features

- Alloy Pump Body
- Polyurethane Impeller
- Maximum Solids 3mm

Applications

- Heavy Duty
- Dirty Water
- Drainage

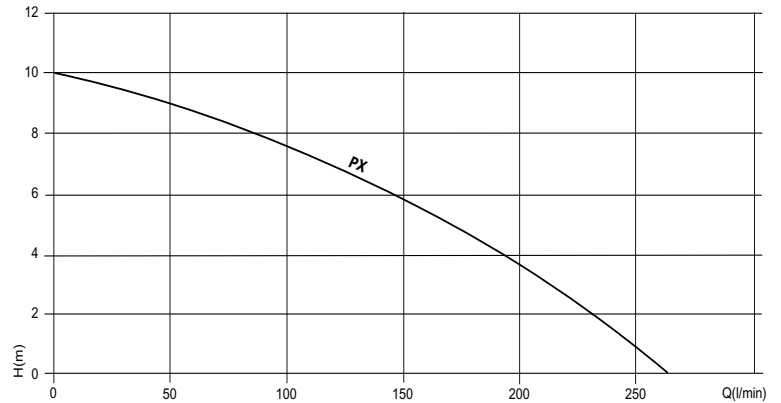

MODEL	VOLT	OUTLET	LM/HM	Kw	AMP	H x W x L mm	Kg	CODE
PONSTAR PX 55022 MAN	230v	2"	260/10	0.62	3.2	308 x 180 x 190	13	PX55022
PONSTAR PX 55022 AUTO	230v	2"	260/10	0.62	3.2	308 x 180 x 190	13	PX55022A
PONSTAR PX 55011 MAN	110v	2"	260/10	0.58	6.5	308 x 180 x 190	13	PX55011
PONSTAR PX 55011 AUTO	110v	2"	260/10	0.58	7	308 x 180 x 190	13	PX55011A

SUBMERSIBLE PUMPS

KOSHIN PONSTAR PBX

A

New PBX, Heavy duty construction and unbeatable performance, suitable for dry running and for use with sandy water. Capacitor start, induction run motor for extra starting torque. Designed so that the delivery flange can be altered from vertical to horizontal. Optional extra float switch with an easy to retro fit or replace system. Twin mechanical seals in a lubricated chamber. 2" male bsp outlet allowing cam fittings, lever couplings and hose tails to be easy fitted. PBX dry run capability, when the pump is running dry the motor is cooled by air, forced through the pump by the impeller and exiting the pump via the air valve preventing the motor from overheating. Complete with 10 metres of power cable and hose tail.

Features

- Polyurethane Pump Body
- Polyurethane Impeller
- Max Solids 3mm

Applications

- Heavy Duty
- Clean Water
- Dirty Water
- Drainage

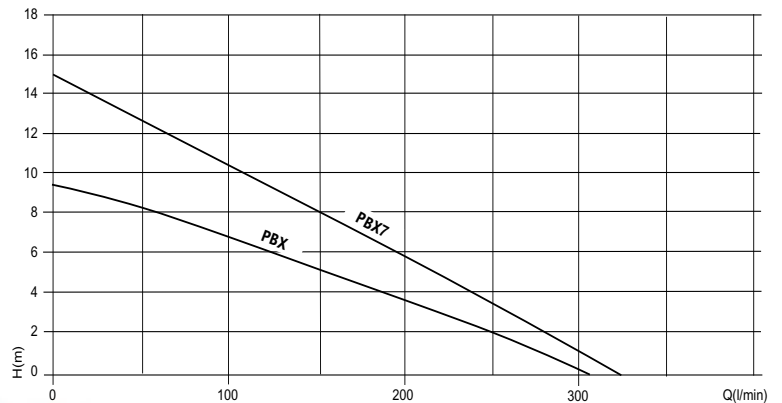

PBX MANUAL



PBX AUTO



PBX7 MANUAL

MODEL	VOLT	OUTLET	LM/HM	Kw	AMP	H x W x L mm	Kg	CODE
PONSTAR PBX 55022 MAN	230v	2"	310/9.5	0.68	4.2	407 x 190 x 190	16.0	040-620
PONSTAR PBX 55022 AUTO	230v	2"	310/9.5	0.68	4.2	407 x 190 x 190	16.0	040-620A
PONSTAR PBX 55011 MAN	110v	2"	310/9.5	0.69	8.1	407 x 190 x 190	16.0	040-624
PONSTAR PBX 55011 AUTO	110v	2"	310/9.5	0.69	8.1	407 x 190 x 190	16.0	040-624A
PONSTAR PBX7 55022 MAN	230v	2"	330/15	1.25	6	407 x 190 x 190	17	040-700
PONSTAR PBX7 55022 AUTO	230v	2"	330/15	1.25	6	407 x 190 x 190	17	040-700A
PONSTAR PBX7 55011 MAN	110v	2"	330/15	1.25	12	407 x 190 x 190	17	040-702
PONSTAR PBX7 55011 AUTO	110v	2"	330/15	1.25	12	407 x 190 x 190	17	040-702A
PONSTAR PBX MAC3 FLOAT								0438210

SUBMERSIBLE PUMPS

JS RST

A

Top outlet, twin mechanical seals, carbon ceramic and silicon carbide in a lubricated chamber. Stainless steel outer case, shaft and motor case. Cast iron lower motor bearing/seal housing, motor top cover and volute. Complete with 10 metres of power cable. Hose tails are supplied only with models RST6, 8 and 15. Suitable for water features, drainage applications, clean and dirty water. H Versions have higher head capabilities.

Features

- Cast Iron Pump Body
- Cast Iron Impeller
- Max Solids RST6-15 6mm
- RST22/H-75H 10mm

Applications

- Heavy Duty
- Clean Water
- Dirty Water
- Drainage

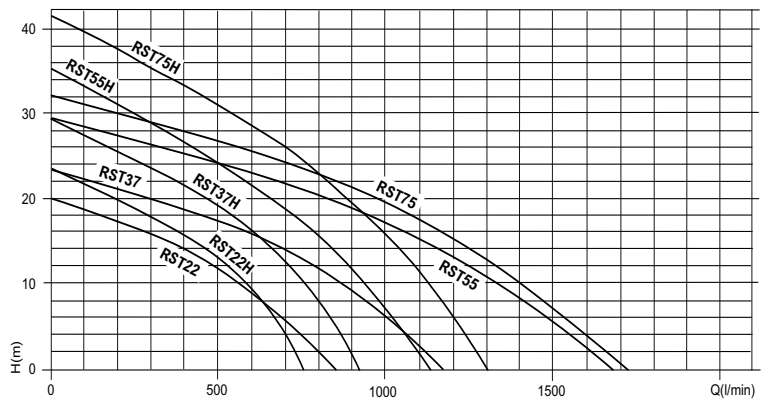
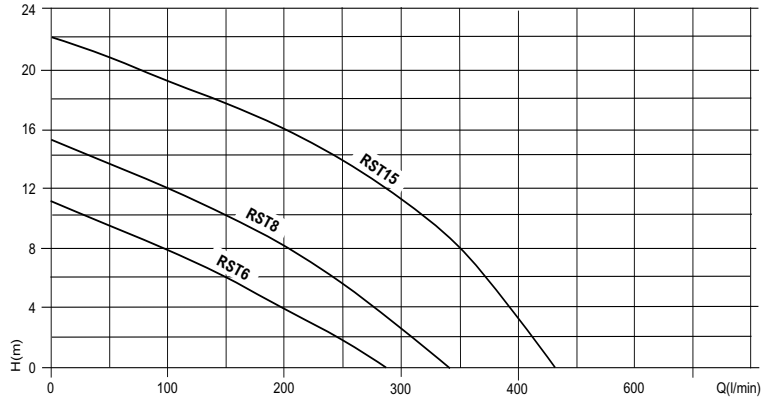

RST22



RST-6

MODEL	VOLT	OUTLET	LM/HM	Kw	AMP	H x W x L mm	Kg	CODE
RST-6	400v	2"	280/11	0.55	1.5	420 x 190 x 190	20	012-006
RST-8	400v	2"	345/18	0.75	1.8	420 x 190 x 190	22	012-008
RST-15	400v	2"	435/22	1.5	3.2	500 x 180 x 180	29	012-015
RST-22	400v	3"	850/20	2.2	4.6	530 x 250 x 250	52	012-022
RST-37	400v	4"	1170/23	3.7	7.9	535 x 250 x 250	56	012-037
RST-55	400v	4"	1670/29	5.5	11.5	640 x 250 x 250	90	012-055
RST-75	400v	4"	1720/32	7.5	15.2	640 x 250 x 250	95	012-075
RST-22H	400v	3"	765/23	2.2	4.6	530 x 250 x 250	52	012-024
RST-37H	400v	3"	920/29	3.7	7.9	535 x 250 x 250	56	012-039
RST-55H	400v	3"	1155/35	5.5	11.5	640 x 250 x 250	90	012-059
RST-75H	400v	4"	1310/41.5	7.5	15.2	640 x 250 x 250	95	012-077

SUBMERSIBLE PUMPS

JS RS

A

Top outlet, twin mechanical seals, carbon ceramic and silicon carbide in a lubricated chamber. Stainless steel outer case, shaft and motor case. Cast iron lower motor bearing/seal housing, motor top cover and volute. Complete with 10 metres of power cable. Hose tails are supplied with all models. Water features, drainage applications, clean and dirty water. Maximum immersion 7 metres.

Features

- Cast Iron Pump Body
- Plastic Impeller RS150-400
- Cast Iron Impeller RS550-750
- Max Solids 6mm

Applications

- Clean Water
- Dirty Water
- Drainage

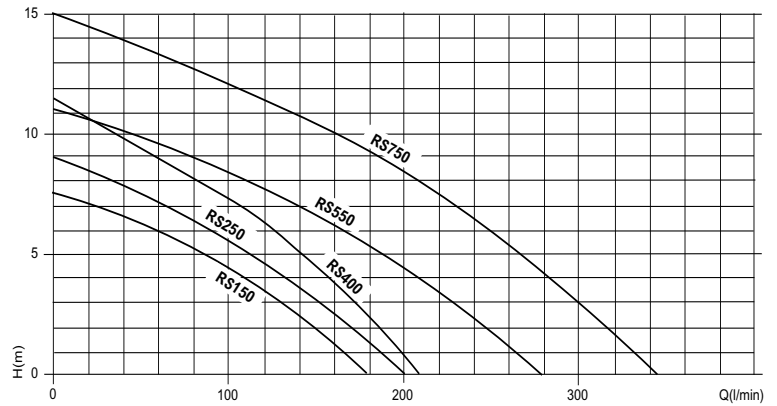

RS250 MAN



RS250A



RS250AG

MODEL	VOLT	OUTLET	LM/HM	Kw	AMP	H x W x L mm	Kg	CODE
RS-150	230v	1¼"	180/7.5	0.15	1.4	370 x 167 x 167	13	010-150
RS-150	110v	1¼"	180/7.5	0.15	3.0	370 x 167 x 167	13	010-152
RS250	230v	1½"	200/9	0.25	1.9	370 x 167 x 167	13	010-250
RS250	110v	1½"	200/9	0.25	4.0	370 x 167 x 167	13	010-252
RS400	230v	2"	210/11.5	0.4	2.8	370 x 167 x 167	13.2	010-400
RS400	110v	2"	210/11.5	0.4	5.6	370 x 167 x 167	13.2	010-402
RS550	230v	2"	280/11	0.55	3.8	413 x 192 x 192	19.4	010-550
RS550	110v	2"	280/11	0.55	7.8	413 x 192 x 192	19.4	010-552
RS750	230v	2"	345/15	0.75	6.8	413 x 192 x 192	19.6	010-750
RS750	110v	2"	345/15	0.75	13.0	413 x 192 x 192	19.6	010-752

MODELS JS/RS

CAN BE MODIFIED FOR AUTOMATIC OPERATION

A

TYPE	CODE
FLOAT SWITCH – MAC3	020-001
FLOAT SWITCH – AGMA 22 MAGNETIC	020-003



MAC3



AGMA

The Agma Float is not recommended to be fitted to the RS750 110v due to the high current rating.

SUBMERSIBLE PUMPS

PENTAX DH-100

E

DH-100 centrifugal drainage pump with open impeller for pumping liquids with suspended solids up to 10mm. Side vertical outlet, double sealing arrangement. Stainless steel outer case and motor shaft. Twin mechanical seals and oil seal. Cast iron lower motor bearing/seal housing. Complete with 10 metres of power cable. No hose tails are supplied with the pumps. Suitable for drainage applications, clean and dirty water. Maximum immersion 5 metres.

Features

- Cast Iron Pump Body
- Brass Impeller
- Max Solids 10mm

Applications

- Heavy Duty
- Clean Water
- Dirty Water
- Drainage

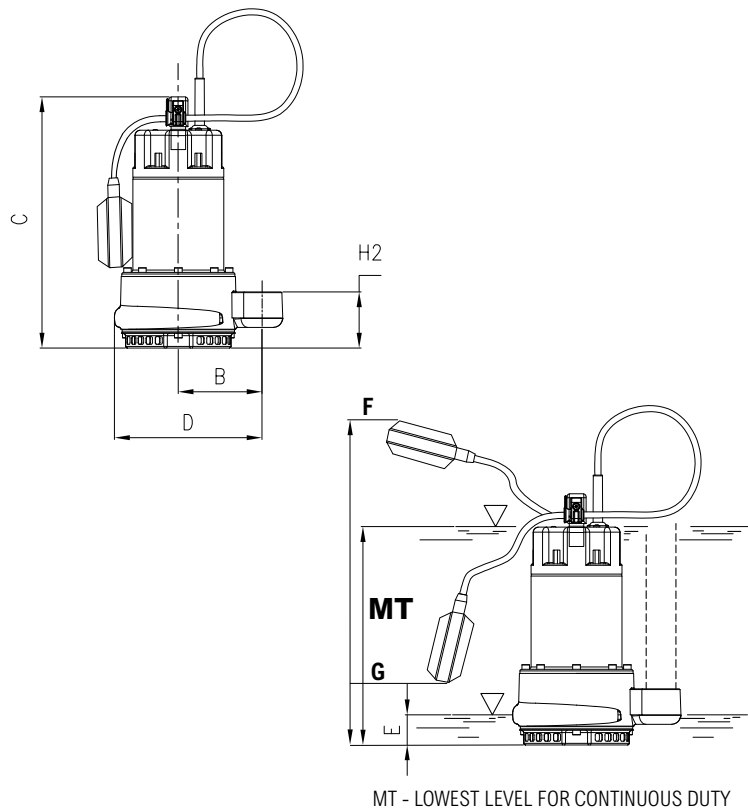
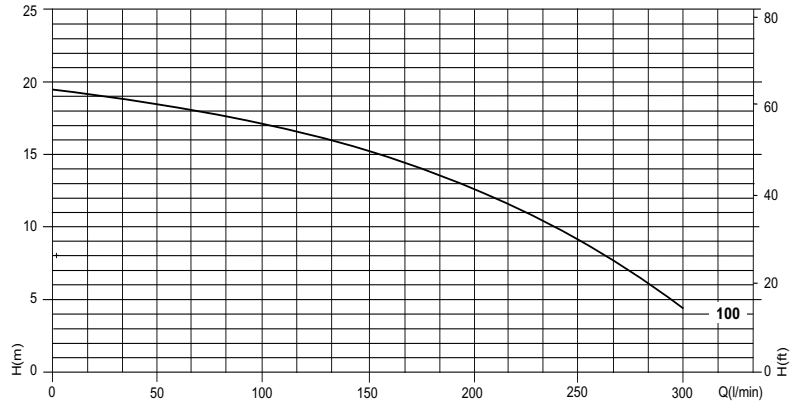

MODEL	B	C	D	E	H2	MT	F ON LEVEL	G OFF LEVEL
DH100 MAN	105	330	219	45	70	190		
DH100 AUTO	105	330	219	45	70	190	420	140

MODEL	VOLT	OUTLET	LM/HM	Kw	AMP	H x W x L mm	Kg	CODE
DH-100 MANUAL	230v	1½"	320/19.4	1.37	6.2	330 x 150 x 220	14	020-616
DH-100 AUTO	230v	1½"	320/19.4	1.37	6.2	330 x 150 x 220	14	020-618

SUBMERSIBLE PUMPS

RS/T AL HIGH FLOW PROPELLER PUMPS

A

Top outlet, high flow propeller pump. Twin mechanical seals, carbon ceramic and silicon carbide in a lubricated chamber. Stainless steel outer case, shaft, motor case, lower motor seal bearing housing and motor top cover. Brass propeller. Complete with 10 metres of power cable. No hose tail is supplied. Suitable for water features, drainage applications, clean and dirty water. All models can be made to work automatically, see pages 78-81 for control panels and 85-89 for float switches.

Features

- S/Steel Pump Body
- Brass Propeller
- Max Solids 5mm

Applications

- Clean Water
- Dirty Water

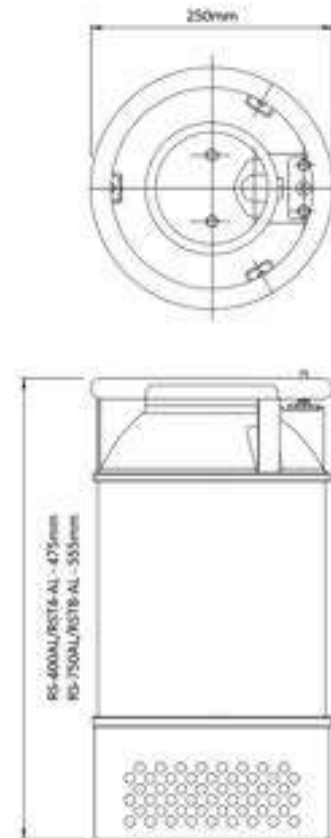
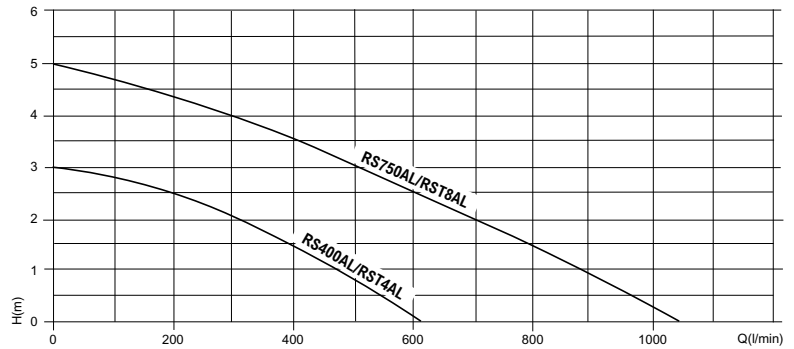

MODEL	VOLT	OUTLET	LM/HM	Kw	AMP	H x W x L mm	Kg	CODE
RS-400 AL	230v	4"	620/3	0.4	2.8	475 x 250 x 250	27	011-500
RS-750 AL	230v	4"	1055/5	0.75	6.8	555 x 250 x 250	27.5	011-501
RST-4 AL	400v	4"	620/3	0.4	1.1	475 x 250 x 250	26	011-502
RST-8 AL	400v	4"	1055/5	0.75	1.8	555 x 250 x 250	27	011-504

JS JST

A



JST 8 2"

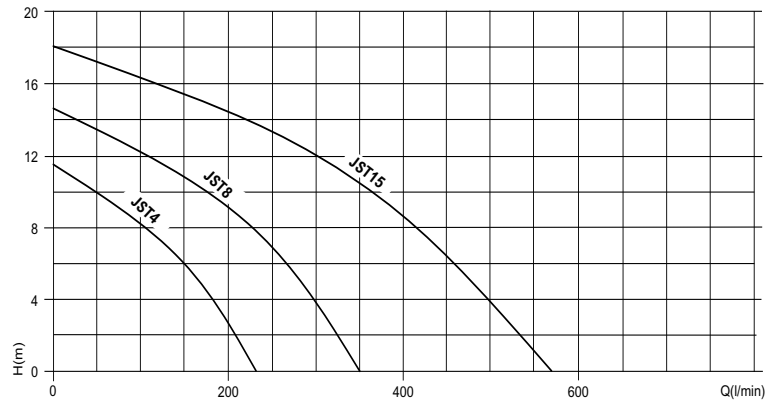

JST 15

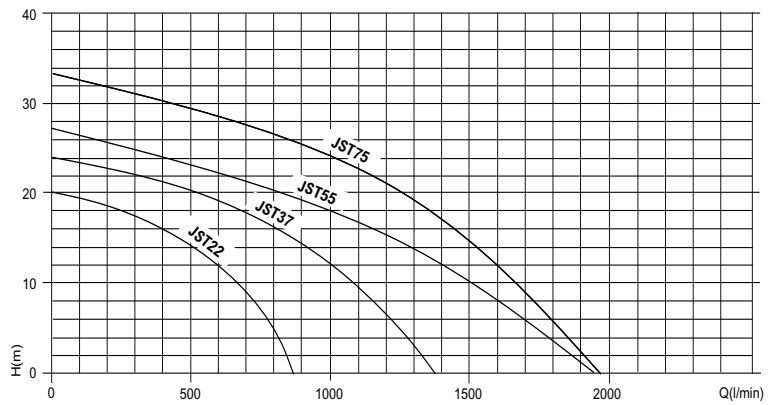

JST 22

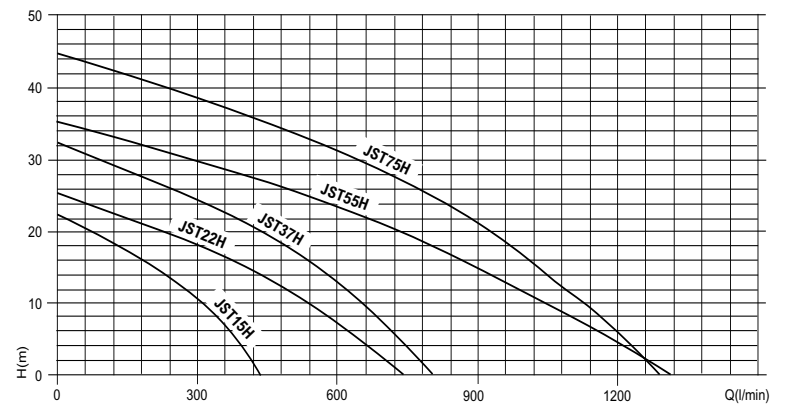

SUBMERSIBLE PUMPS

JS JST

A

Side vertical outlet, twin mechanical seals, carbon ceramic and silicon carbide in a lubricated chamber. Stainless steel shaft and motor case. Cast iron lower motor bearing/seal housing, motor top cover and volute. Complete with 10 metres of power cable. Hose tails are supplied only with models JST-4 up to JST-22 and JST-15H up to JST-55H. Suitable for water features, drainage applications, clean and dirty water. H Versions have higher head capabilities. All models can be made to work automatically, see pages 78-81 for control panels and 85-89 for float switches.

Features

Cast Iron
 Cast Iron Impeller
 Max Solids JST4-15(H) 6mm
 JST22(H)-75(H) 10mm

Applications

Heavy Duty
 Clean Water
 Dirty Water
 Drainage



JST 8 2"



JST 55

MODEL	VOLT	OUTLET	LM/HM	Kw	AMP	H x W x L mm	Kg	CODE
JST-4	400v	2"	230/11.5	0.4	1.1	370 x 145 x 220	10	011-004
JST-8	400v	2"	350/14.5	0.8	1.8	420 x 190 x 260	25	011-008 2"
JST-8	400v	3"	350/14.5	0.8	1.8	420 x 190 x 280	25	011-008 3"
JST-15	400v	3"	565/18	1.5	3.2	440 x 190 x 280	27	011-015
JST-22	400v	3"	865/20	2.2	4.6	510 x 220 x 315	39	011-022
JST-37	400v	4"	1375/24	3.7	7.9	525 x 220 x 320	45	011-037
JST-55	400v	4"	1945/27	5.5	11.5	640 x 280 x 500	90	011-055
JST-75	400v	6"	1970/33	7.5	15.2	720 x 280 x 500	95	011-075
JST-15H	400v	2"	435/22	1.5	3.2	440 x 190 x 280	27	011-019
JST-22H	400v	2"	745/25	2.2	4.6	510 x 220 x 315	39	011-023
JST-37H	400v	2"	805/32	3.7	7.9	525 x 220 x 320	45	011-039
JST-55H	400v	3"	1320/35	5.5	11.5	640 x 280 x 500	90	011-057
JST-75H	400v	4"	1290/44.5	7.5	15.2	720 x 280 x 500	95	011-077

SUBMERSIBLE PUMPS

JS HEAVY DUTY CONTRACTOR PUMPS

A

Side vertical outlet, twin mechanical seals, carbon ceramic and silicon carbide in a lubricated chamber. Stainless steel shaft and motor case. Cast iron lower motor bearing/seal housing, motor top cover and volute. Complete with 10 metres of power cable. Hose tails are supplied with all models. Suitable for water features, drainage applications, clean and dirty water. Automatic pumps are fitted with MAC-3 floats, allow approx 300mm away from the pump to operate correctly. See pages 78-81 for control panels and 85-89 for float switches.

Features

- Cast Iron Pump Body
- Plastic Impeller JS250-400
- Max Solids 6mm

Applications

- Heavy Duty
- Clean Water
- Dirty Water
- Drainage

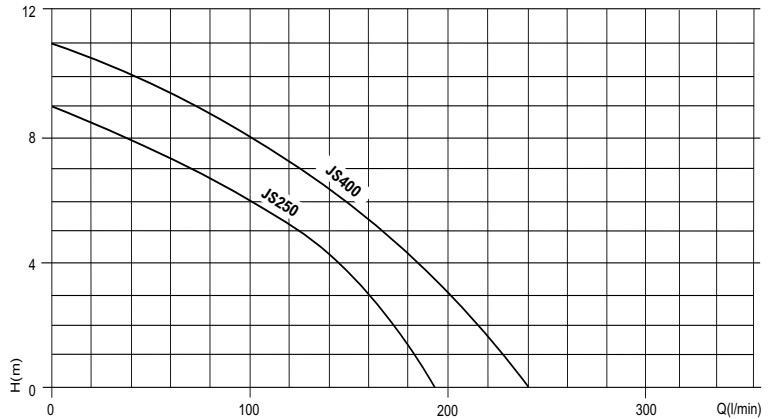

JS400 MANUAL



JS400 AUTO

MODEL	VOLT	OUTLET	LM/HM	Kw	AMP	H x W x L mm	Kg	CODE
JS-250 MANUAL	230v	1½"	195/9	0.25	1.9	370 x 150 x 220	12	011-200
JS-250 AUTO	230v	1½"	195/9	0.25	1.9	370 x 150 x 220	12	011-200A
JS-250 MANUAL	110v	1½"	195/9	0.25	4	370 x 150 x 220	12	011-202
JS-250 AUTO	110v	1½"	195/9	0.25	4	370 x 150 x 220	12	011-202A
JS-400 MANUAL	230v	2"	240/11	0.4	3.8	420 x 150 x 220	15	011-400
JS-400 AUTO	230v	2"	240/11	0.4	3.8	420 x 150 x 220	15	011-400A
JS-400 MANUAL	110v	2"	240/11	0.4	7.8	420 x 150 x 220	15	011-402
JS-400 AUTO	110v	2"	240/11	0.4	7.8	420 x 150 x 220	15	011-402A

SUBMERSIBLE PUMPS

JS HEAVY DUTY CONTRACTOR PUMPS

A

Side vertical outlet, twin mechanical seals, carbon ceramic and silicon carbide in a lubricated chamber. Stainless steel shaft and motor case. Cast iron lower motor bearing/seal housing, motor top cover and volute. Complete with 10 metres of power cable. Hose tails are supplied with all models. Suitable for water features, drainage applications, clean and dirty water. H Versions have higher head capabilities. Automatic pumps are fitted with MAC-3 floats, allow approx 300mm away from the pump to operate correctly. See pages 78-81 for control panels and 85-81 for float switches.

Features

- Cast Iron Pump Body
- Cast Iron Impeller JS750-1500(H)
- Max Solids 6mm

Applications

- Heavy Duty
- Clean Water
- Dirty Water
- Drainage

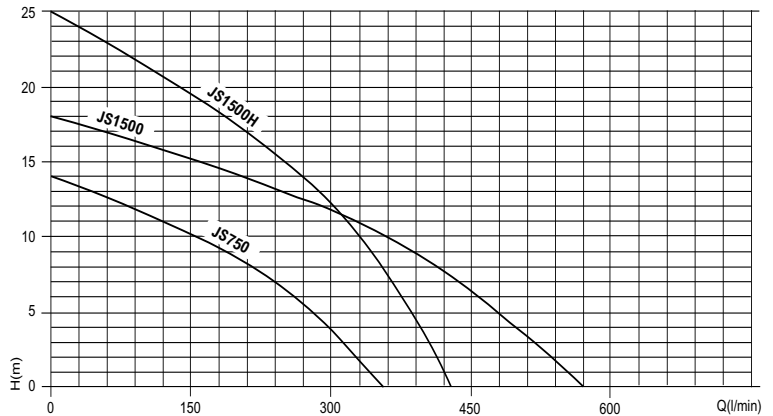

JS1500 MANUAL



JS750 AUTO

MODEL	VOLT	OUTLET	LM/HM	Kw	AMP	H x W x L mm	Kg	CODE
JS-750 MANUAL	230v	2"	355/14	0.75	6.8	480 x 195 x 255	26	011-750 2"
JS-750 AUTO	230v	2"	355/14	0.75	6.8	480 x 195 x 255	26	011-750A 2"
JS-750 MANUAL	110v	2"	355/14	0.75	13	480 x 195 x 255	26	011-752 2"
JS-750 AUTO	110v	2"	355/14	0.75	13	480 x 195 x 255	26	011-752A 2"
JS-750 MANUAL	230v	3"	355/14	0.75	6.8	480 x 195 x 285	27	011-750 3"
JS-750 AUTO	230v	3"	355/14	0.75	6.8	480 x 195 x 285	27	011-750A 3"
JS-750 MANUAL	110v	3"	355/14	0.75	13	480 x 195 x 285	27	011-752 3"
JS-750 AUTO	110v	3"	355/14	0.75	13	480 x 195 x 285	27	011-752A 3"
JS-1500 MANUAL	230v	3"	570/18	1.5	12	510 x 195 x 285	32	011-760
JS-1500 AUTO	230v	3"	570/18	1.5	12	510 x 195 x 285	32	011-760A
JS-1500H MANUAL	230v	2"	430/25	1.5	12	480 x 195 x 255	32	011-764
JS-1500H AUTO	230v	2"	430/25	1.5	12	480 x 195 x 255	32	011-764A

SUBMERSIBLE PUMPS

JST SV SEWAGE PUMPS

A

JST-SV side vertical outlet (removable for coupling foot) submersible sewage vortex impeller pumps allowing soft solids to be passed through the pump body to waste. Available as free standing as standard or can be guide rail mounted. Twin mechanical seals, carbon ceramic and silicon carbide in a lubricated chamber. Complete with 10 metres of power cable. Hose tails are supplied up to and including model JST-37 SV. JST-37 SV (57mm) is a high head version with an 57mm solids handling capability. The standard JST-37 SV (80mm) is the standard version with an 80mm solids handling capability. All models can be made to work automatically, see pages 78-81 for control panels and 85-89 for float switches.

Features

- Cast Iron Pump Body
- Cast Iron Vortex Impeller
- Max Solids
- JST4/8SV **35mm** 15SV **65mm**
- JST22SV **65mm** 22SV4 **80mm**
- 37SV **57mm** 37SV **80mm**
- JST55/75SV **80mm**



Applications

- Heavy Duty
- Clean Water
- Dirty Water
- Drainage
- Sewage



JST8SV



JST55/75SV

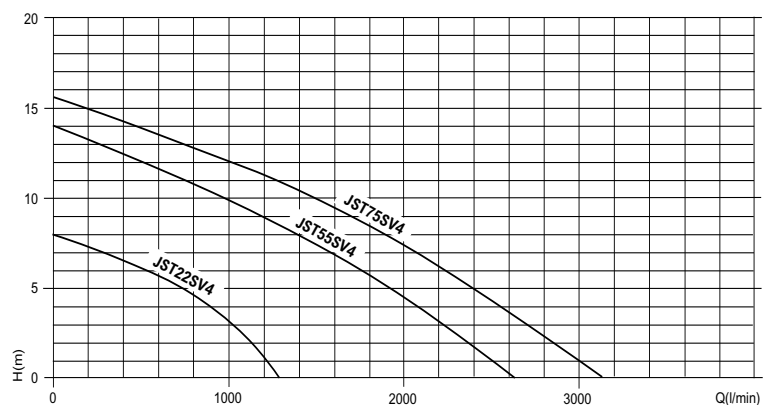
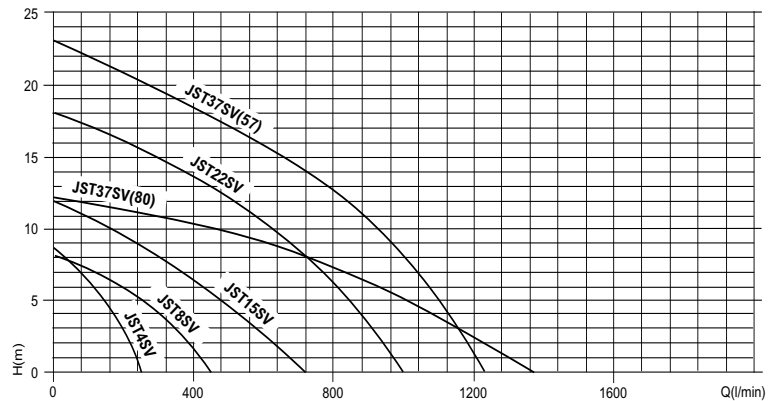

MODEL	VOLT	OUTLET	LM/HM	Kw	AMP	H x W x L mm	Kg	CODE
JST-4 SV	400v	2"	250/8.5	0.4	1.1	415 x 140 x 280	15.4	012-698
JST-8 SV	400v	3"	450/8	0.75	1.8	470 x 170 x 345	29.4	012-768
JST-15 SV	400v	3"	720/12	1.5	3.2	515 x 170 x 357	36.6	012-774
JST-22 SV 2 POLE	400v	3"	1000/18	2.2	4.6	580 x 210 x 430	52.2	011-026
JST-22 SV4 POLE	400v	3"	1300/8	2.2	4.6	650 x 255 x 480	59.6	011-025
JST-37 SV (80mm)	400v	3"	1370/12	3.7	7.9	660 x 255 x 480	61.2	011-040
JST-37 SV (57mm)	400v	3"	1235/23	3.7	7.9	660 x 255 x 480	61.2	011-052
JST-55 SV4 POLE	400v	4"	2650/14	5.5	11.5	830 x 310 x 650	125	012-788
JST-75 SV4 POLE	400v	4"	3175/15.5	7.5	15.2	830 x 310 x 650	135	012-792

COUPLING FOOT, CLAW & TOP BRACKET KITS

MODEL	SIZE	CODE
SR-50S	2"	020-501S
SR-80	3"	020-504
SR-100	4"	020-506



SR50S



SR80/100

Dimensions on page 30.

SUBMERSIBLE PUMPS

JS SV SEWAGE PUMPS

A

Side vertical outlet (removable for coupling foot), twin mechanical seals, carbon ceramic and silicon carbide in a lubricated chamber. Stainless steel shaft and motor case. Cast iron lower motor bearing/seal housing, motor top cover and volute. Complete with 10 metres of power cable. Hose tails are supplied with all models. Suitable for drainage, dirty water and sewage applications. Automatic pumps are fitted with MAC-3 floats, allow approx 300mm away from the pump to operate correctly. See pages 71-81 for control panels and 85-89 for float switches.

Features

- Cast Iron Pump Body
- Cast Iron Vortex Impeller
- Max Solids
- JS400SV 650SV **35mm**
- JS750SV **46mm** JS1500SV **65mm**

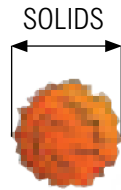

Applications

- Heavy Duty
- Dirty Water
- Drainage
- Sewage



JS750SVA

JS1500SV

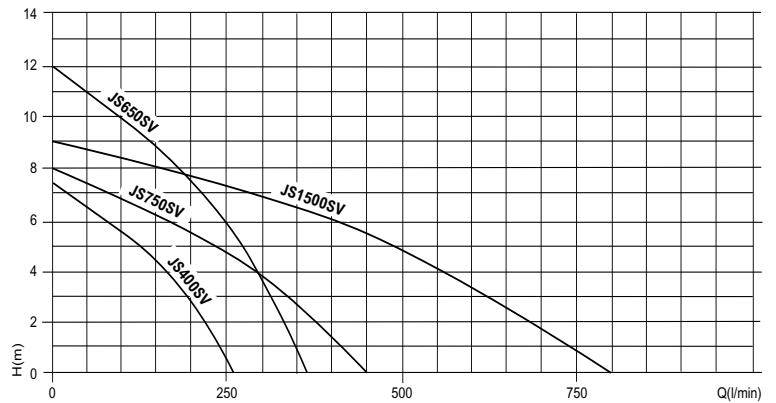

MODEL	VOLT	OUTLET	LM/HM	Kw	AMP	H x W x L mm	Kg	CODE
JS-400SV MANUAL	230v	2"	260/7.5	0.4	3.8	460 x 160 x 275	18.6	012-410
JS-400SV AUTO	230v	2"	260/7.5	0.4	3.8	460 x 160 x 275	18.6	012-410A
JS-400SV MANUAL	110v	2"	260/7.5	0.4	7.6	460 x 160 x 275	18.6	012-414
JS-400SV AUTO	110v	2"	260/7.5	0.4	7.6	460 x 160 x 275	18.6	012-414A
JS-650SV MANUAL	230v	2"	360/12	0.75	5.5	485 x 160 x 275	22.1	011-700
JS-650SV AUTO	230v	2"	360/12	0.75	5.5	485 x 160 x 275	22.1	011-700A
JS-650SV MANUAL	110v	2"	360/12	0.75	11	485 x 160 x 275	22.1	011-702
JS-650SV AUTO	110v	2"	360/12	0.75	11	485 x 160 x 275	22.1	011-702A
JS-750SV MANUAL	230v	3"	450/8	0.75	6.8	530 x 160 x 325	32.3	012-751
JS-750SV AUTO	230v	3"	450/8	0.75	6.8	530 x 160 x 325	32.3	012-751A
JS-750SV MANUAL	110v	3"	450/8	0.75	13	530 x 160 x 325	32.3	012-754
JS-750SV AUTO	110v	3"	450/8	0.75	13	530 x 160 x 325	32.3	012-754A
JS-1500SV MANUAL	230v	3"	795/9	1.5	12	615 x 190 x 357	41	011-768
JS-1500SV AUTO	230v	3"	795/9	1.5	12	615 x 190 x 357	41	011-768A

COUPLING FOOT, CLAW & TOP BRACKET KITS

MODEL	SIZE	CODE
SR-50S	2"	020-501S
SR-80	3"	020-504



SR50S



SR80

Dimensions on page 30.

SUBMERSIBLE PUMPS

JST SK SEWAGE PUMPS

A

Side vertical outlet (removable for coupling foot), twin mechanical seals, carbon ceramic and silicon carbide in a lubricated chamber. Stainless steel shaft and motor case. Cast iron lower motor bearing/seal housing, motor top cover and volute. Complete with 10 metres of power cable. Hose tails are supplied with all 2" and 3" models. Suitable for drainage, dirty water and sewage applications. Single channel tungsten tipped impeller capable of cutting soft solids into smaller parts to pump through the body to waste. All models can be made to work automatically, see pages 78-81 for control panels and 85-89 for float switches.

Features

- Cast Iron Pump Body
- Single Channel Impeller
- Max Solids
 JST8SK **21mm** 15SK & 22SK **44mm**
 JST37SK **35mm** 55SK 75SK **60mm**
 JST110SK **50mm**



Applications

- Heavy Duty
- Dirty Water
- Drainage
- Sewage

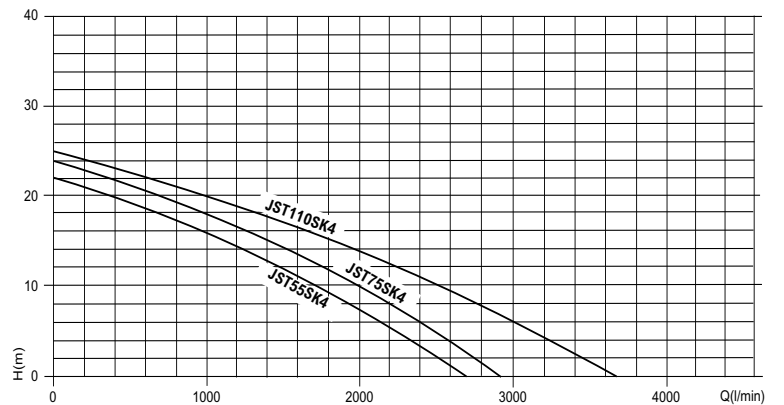
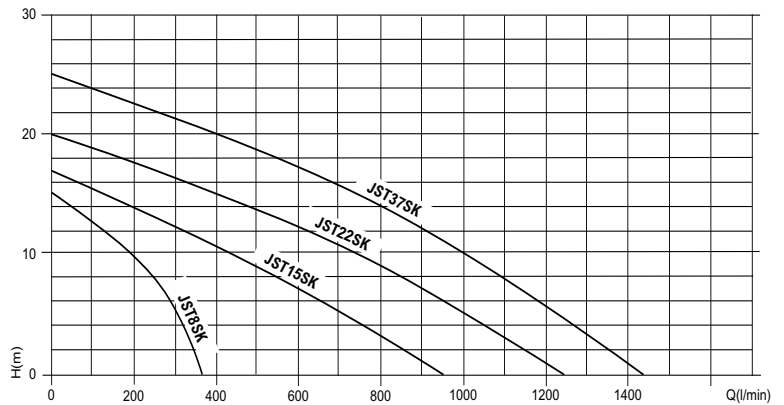

JST8SK

JST55/75SK

MODEL	VOLT	OUTLET	LM/HM	Kw	AMP	H x W x L mm	Kg	CODE
JST-08SK	400v	2"	370/15	0.75	1.8	465 x 195 x 315	28	012-780
JST-15SK	400v	3"	955/17.5	1.5	3.2	515 x 240 x 375	37	012-782
JST-22SK	400v	3"	1250/20	2.2	4.6	565 x 240 x 405	50	012-784
JST-37SK	400v	4"	1440/25	3.7	7.9	610 x 250 x 405	55	012-786
JST-55SK4	400v	4"	2730/22	5.5	11.5	730 x 420 x 740	140	012-790
JST-75SK4	400v	4"	2935/24	7.5	15.2	750 x 420 x 740	150	012-796
JST-110SK4	400v	6"	3685/27.5	11	22.7	910 x 480 x 900	230	012-805

COUPLING FOOT, CLAW & TOP BRACKET KITS

MODEL	SIZE	CODE
SR-50S	2"	020-501S
SR-80	3"	020-504
SR-100	4"	020-506



SR50S



SR80/100

Dimensions on page 30.

SUBMERSIBLE PUMPS

JS SK SEWAGE PUMPS

A

Side vertical outlet (removable for coupling foot), twin mechanical seals, carbon ceramic and silicon carbide in a lubricated chamber. Stainless steel shaft and motor case. Cast iron lower motor bearing/seal housing, motor top cover and volute. Complete with 10 metres of power cable. Hose tails are supplied with all models. Suitable for drainage, dirty water and sewage applications. Single channel tungsten tipped impeller capable of cutting soft solids into smaller parts to pump through the body to waste. See pages 78-81 for control panels and 85-89 for float switches.

Features

- Cast Iron Pump Body
- Single Channel Impeller
- Max Solids
JS750SK **21mm**
JS1500SK **44mm**

Applications

- Heavy Duty
- Dirty Water
- Drainage
- Sewage

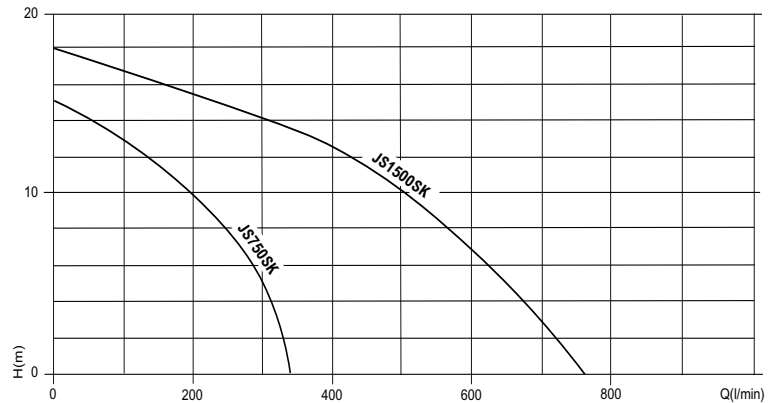
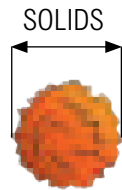

JS750SK



MODEL	VOLT	OUTLET	LM/HM	Kw	AMP	H x W x L mm	Kg	CODE
JS-750SK MANUAL	230v	2"	335/15	0.75	6.8	530 x 190 x 310	29	012-757
JS-750SK AUTO	230v	2"	335/15	0.75	6.8	530 x 190 x 310	29	012-757A
JS-750SK MANUAL	110v	2"	335/15	0.75	13	530 x 190 x 310	29	012-758
JS-750SK AUTO	110v	2"	335/15	0.75	13	530 x 190 x 310	29	012-758A
JS-1500SK MANUAL	230v	3"	765/18	1.5	12	580 x 240 x 360	36	011-776
JS-1500SK AUTO	230v	3"	765/18	1.5	12	580 x 240 x 360	36	011-776A

COUPLING FOOT, CLAW & TOP BRACKET KITS

MODEL	SIZE	CODE
SR-50S	2"	020-501S
SR-80	3"	020-504

Dimensions on page 30.



SR50S



SR80

SUBMERSIBLE PUMPS

JS GUIDE RAIL KIT DIMENSIONS

SR50 (2")

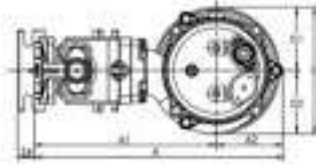

JS FLANGE

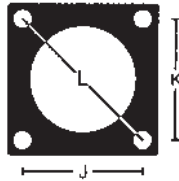

SR80 (3")
SR100 (4")

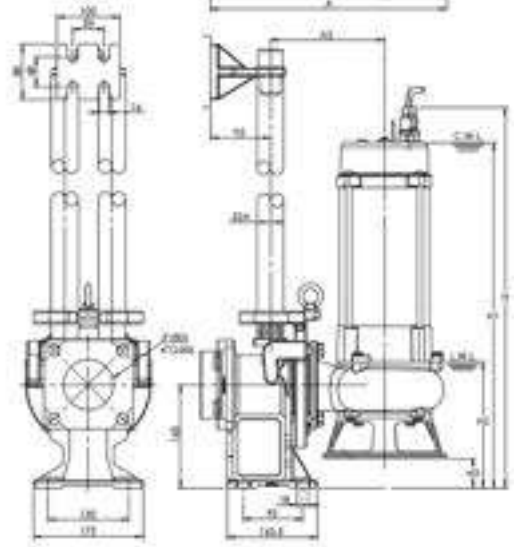
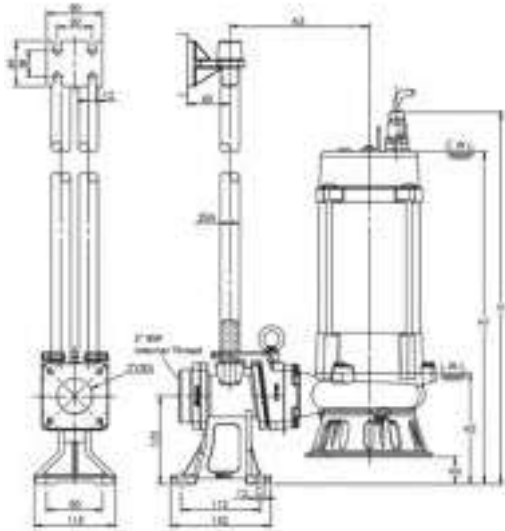
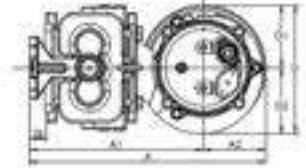

TYPE	SIZE	A	A1	A2	A3	D	D1	D2	H	H1	H2	H3	J	K	L
JS250SV	2" (50)	312	238	74	178	135	64	71	407	377	176	56	70	70	100
JS400SV	2" (50)	312	238	74	178	135	64	71	452	422	176	56	70	70	100
JS650SV	2" (50)	325	243	82	183	150	73	77	496	440	172	48	70	70	100
JS750SV	3" (80)	363	269	94	174	170	85	85	516	460	218	78	110	110	155
JS1500SV	3" (80)	375	279	96	184	190	91	99	635	579	243	48	110	110	155
JST4SV	2" (50)	312	238	74	178	135	64	71	407	377	176	56	70	70	100
JST8SV	3" (80)	363	269	94	174	170	85	85	516	460	218	78	110	110	155
JST15SV	3" (80)	375	279	96	184	190	91	99	567	511	243	48	110	110	155
JST22SV	3" (80)	416	312	104	217	206	103	103	643	546	240	60	110	110	155
JST37SV (80mm)	3" (80)	450	317	133	222	252	119	133	695	598	253	15	110	110	155
JST37SV (57mm)	3" (80)	416	312	104	217	206	103	103	603	506	240	60	110	110	155
JST22SV4	3" (80)	450	317	133	222	252	119	133	735	638	253	15	110	110	155
JST55SV4	4" (100)	524	365	159	-	315	155	160	-	725	335	25	120	120	170
JST75SV4	4" (100)	524	365	159	-	315	155	160	-	760	335	25	120	120	170
JS750SK	2" (50)	354	258	96	198	180	90	90	529	473	157	38	70	70	100
JS1500SK	3" (80)	381	281	100	186	206	100	106	616	560	210	55	110	110	155
JST8SK	2" (50)	354	258	96	198	180	90	90	469	413	157	38	110	110	155
JST15SK	3" (80)	381	281	100	186	206	100	106	548	492	210	55	110	110	155
JST22SK	3" (80)	404	300	104	205	214	103	111	629	532	211	55	110	110	155
JST37SK*	3" (80)	417	297	120	202	240	120	120	651	554	218	41	110	110	155
JST55SK	4" (100)	595	395	200	-	420	168	252	730	685	285	-	120	120	170
JST75SK	4" (100)	595	395	200	-	420	168	252	730	735	285	-	120	120	170
GS1200	2" (50)	348	251	97	191	170	85	85	535	479	152	43	70	70	100
GS1500	2" (50)	355	258	97	198	180	85	95	582	526	152	43	70	70	100
GST12	2" (50)	348	251	97	191	170	85	85	476	420	152	43	70	70	100
GST15	2" (50)	355	258	97	198	180	85	95	514	458	152	43	70	70	100
GST22	2" (50)	389	284	105	224	206	100	106	611	514	152	59	70	70	100
GST37	2" (50)	389	284	105	224	206	100	106	626	529	152	59	70	70	100

JS GUIDE RAIL KIT-STOOL, CLAW & TOP BRACKET

A

The new and improved JS SR50 guide rail coupler and claw, with 2" BSP horizontal discharge. The claw fits onto the JS 2" pumps (including the new style JS250/400/650SV). By fitting a universal 2" female adapter onto the claw other manufacturers pumps can now be fitted. A 2" BSP nipple may be required.

The new and improved JS SR80/100 guide rail coupler and claw, with 3"/4" horizontal discharge. The claw fits directly onto the JS 3"/4" pumps. The claw also has DN80/DN100 fixings, so pumps from different manufacturers can now be fitted directly onto the SR80/100.

JS DN flange adapters are now available to take the standard JS 3" and 4" pumps and turn them into DN80/DN100 fixings. Using these flange adapters the JS 3" and 4" pumps can now be retro fitted onto other manufacturers guide rails with DN fixings.

Features

- 2"
- 3"
- 4"

Applications

Heavy Duty
Sewage Vessels



SR50S



SR80



3"/4" JS-DN ADAPTER



2"/3"/4" JS UNIVERSAL ADAPTER



MODEL	OUTLET	Kg	CODE
SR50S	2"	7	020-501S
SR80	3"	18	020-504
SR100	4"	0.7	020-506
2" UNIVERSAL ADAPTER	2"	1.9	SR5038-2
3" UNIVERSAL ADAPTER	3"	8.6	SR8038-2
4" UNIVERSAL ADAPTER	4"	9.7	SR10038-2
JS 3" TO DN80 ADAPTER	JS 3" - 3" DN80	8.6	020-507
JS 4" TO DN100 ADAPTER	JS 4" - 4" DN100	9.7	020-508

SUBMERSIBLE PUMPS

JS GST GRINDER SEWAGE PUMPS

A

Free standing or can be guide rail mounted. Side vertical outlet (removable for coupling foot), twin mechanical seals, carbon ceramic and silicon carbide in a lubricated chamber. Tungsten carbide cutters and grinding rings which allow up to 28,000 cuts per minute. Used for domestic and industrial applications where either high heads or long distances prohibit the use of standard submersibles or large bore discharge pipe is not available or uneconomical to install. Hose tails are supplied with all models. Complete with 10 metres of power cable. See pages 78-81 for control panels and 88-89 for float switches.

Features

- Cast Iron Pump Body
- Cast Iron Impeller
- Tungsten Carbide Cutters
- Max Solids 3mm

Applications

- Heavy Duty
- Sewage

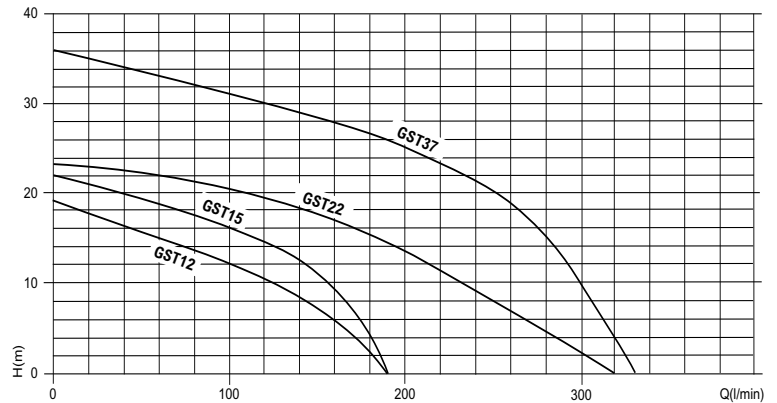

GST 22/37



CUTTER & CUTTING RING



**TWIN SEWAGE STATION
USING 2 JS GRINDER PUMPS**

MODEL	VOLT	OUTLET	LM/HM	Kw	AMP	H x W x L mm	Kg	CODE
GST-12	400v	1¼"	190/19	1.2	2.7	460 x 170 x 310	30	020-712
GST-15	400v	1¼"	190/22	1.5	3.2	490 x 180 x 315	33.8	020-715
GST-22	400v	2"	320/23	2.2	4.6	550 x 235 x 370	48.8	020-720
GST-37	400v	2"	330/36	3.7	7.9	560 x 235 x 370	53	020-737

COUPLING FOOT, CLAW & TOP BRACKET KITS

MODEL	SIZE	CODE
SR-50S	2"	020-501S

Dimensions on page 30.



SR50S

SUBMERSIBLE PUMPS

JS GS GRINDER SEWAGE PUMPS

A

Free standing or can be guide rail mounted. Side vertical outlet (removable for coupling foot), twin mechanical seals, carbon ceramic and silicon carbide in a lubricated chamber. Tungsten carbide cutters and grinding rings which allow up to 28,000 cuts per minute. Used for domestic and industrial applications where either high heads or long distances prohibit the use of standard submersibles or large bore discharge pipe is not available or uneconomical to install. Hose tails are supplied with all models. Complete with 10 metres of power cable. See pages 78-81 for control panels and 85-89 for float switches.

Features

- Cast Iron Pump Body
- Cast Iron Impeller
- Tungsten Carbide Cutters
- Max Solids 3mm

Applications

- Heavy Duty
- Sewage

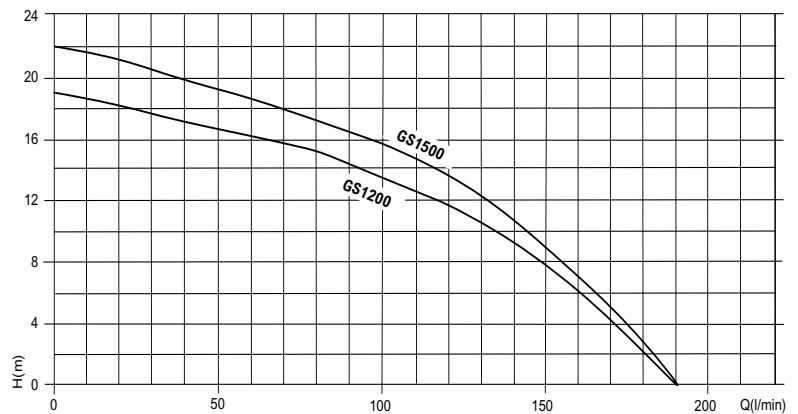

GS1200



CUTTER & CUTTING RING



TWIN SEWAGE STATION
USING 2 JS GRINDER PUMPS

MODEL	VOLT	OUTLET	LM/HM	Kw	AMP	H x W x L mm	Kg	CODE
GS-1200 MANUAL	230v	1¼"	190/19	1.2	9.9	510 x 170 x 310	32.6	020-702
GS-1200 AUTO	230v	1¼"	190/19	1.2	9.9	510 x 170 x 310	32.6	020-702A
GS-1200 MANUAL	110v	1¼"	190/19	1.2	20	510 x 170 x 310	32.6	020-704
GS-1200 AUTO	110v	1¼"	190/19	1.2	20	510 x 170 x 310	32.6	020-704A
GS-1500 MANUAL	230v	1¼"	190/22	1.5	12	565 x 180 x 315	36.2	020-707
GS-1500 AUTO	230v	1¼"	190/22	1.5	12	565 x 180 x 315	36.2	020-707A

COUPLING FOOT, CLAW & TOP BRACKET KITS

MODEL	SIZE	CODE
SR-50S	2"	020-501S

Dimensions on page 30.



SR50S

SUBMERSIBLE PUMPS

PENTAX DTR/DTRT HIGH HEAD GRINDER

E

Free standing or can be guide rail mounted. Side horizontal outlet, twin mechanical seals, carbon ceramic and silicon carbide in a lubricated chamber. Used for domestic and industrial applications where either high heads or long distances prohibit the use of standard submersible or large bore discharge pipe is not available or uneconomical to install. Single phase models have external capacitor supplied loose. Maximum immersion 20m. Complete with 10m power cable. All models can be made to work automatically, see pages 78-81 for control panels and 85-89 for float switches.

Features

Cast Iron Pump Body
Cast Iron Impeller
Max Solids 3mm

Applications

Heavy Duty
Sewage

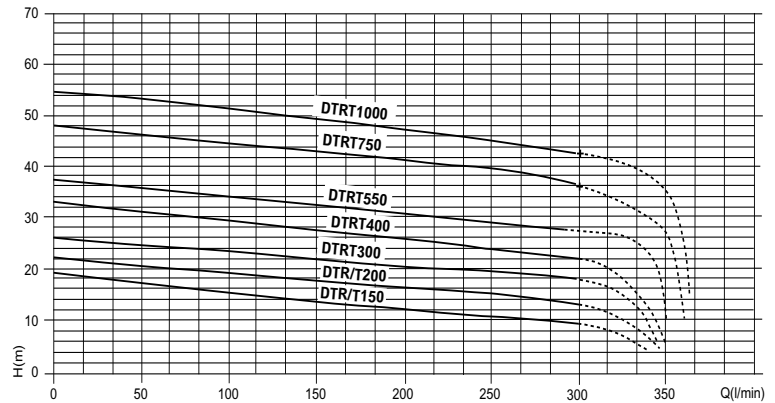

MODEL	VOLT	OUTLET	LM/HM	Kw	AMP	H x W x L mm	Kg	CODE
DTR 150	230v	2"	300/19	1.1	11.5	513 x 237 x 291	35	020-650
DTR 200	230v	2"	300/22	1.5	13.6	513 x 237 x 291	36	020-652
DTRT 150	400v	2"	300/19	1.1	4.4	513 x 237 x 291	35	020-654
DTRT 200	400v	2"	300/22	1.5	5.1	513 x 237 x 291	36	020-656
DTRT 300	400v	2"	300/26	2.2	5.8	513 x 237 x 291	37	020-658
DTRT 400	400v	DN50	350/33	3	7.5	595 x 237 x 350	59	020-660
DTRT 550	400v	DN50	350/38	4	9.2	595 x 237 x 350	66	020-662
DTRT 750	400v	DN65	360/47	5.5	13.9	680 x 279 x 430	94	020-664
DTRT 1000	400v	DN65	360/54	7.5	15.5	680 x 279 x 430	97	020-666
DN50 COUNTER FLANGE KIT								M6222221
DN65 COUNTER FLANGE KIT								M6222222

SUBMERSIBLE PUMPS

PENTAX DC/DCT HIGH HEAD

E

Free standing or can be guide rail mounted. Side horizontal outlet, twin mechanical seals, carbon ceramic and silicon carbide in a lubricated chamber. Used for domestic and industrial applications where either high heads or long distances are required. Single phase models have external capacitor supplied loose. Maximum immersion 20 metres. Complete with 10 metres power cable. Maximum liquid temperature 40°C. All models can be made to work automatically, see pages 78-81 for control panels and 85-89 for float switches.

Features

- Cast Iron Pump Body
- Cast Iron Impeller
- Max Solids 10mm

Applications

- Heavy Duty
- Clean Water
- Dirty Water

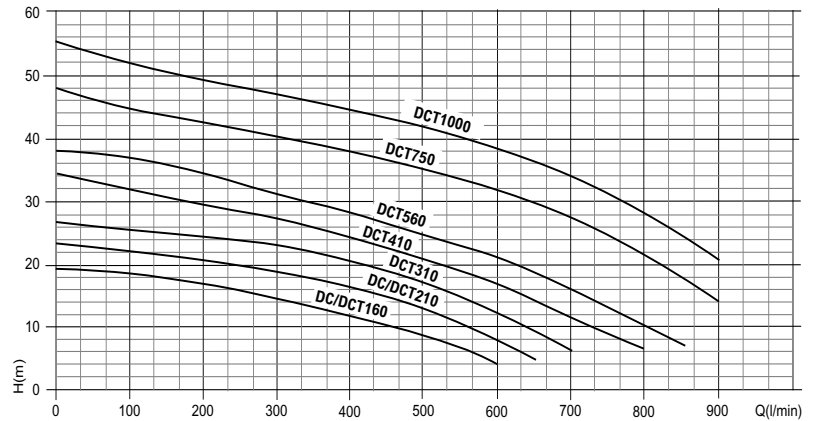

MODEL	VOLT	OUTLET	LM/HM	Kw	AMP	H x W x L mm	Kg	CODE
DC 160	230v	2"	600/19	1.1	13.8	513 x 237 x 291	35	020-630
DC 210	230v	2"	650/23	1.5	16.5	513 x 237 x 291	36	020-632
DCT 160	400v	2"	600/19	1.1	4.8	513 x 237 x 291	35	020-634
DCT 210	400v	2"	650/23	1.5	5.9	513 x 237 x 291	36	020-636
DCT 310	400v	2"	700/26	2.2	6.9	513 x 237 x 291	37	020-638
DCT 410	400v	DN50	800/34	3	8.9	595 x 237 x 350	56	020-640
DCT 560	400v	DN50	850/38	4	10.7	595 x 237 x 350	64	020-642
DCT 750	400v	DN65	900/47	5.5	15.3	680 x 279 x 430	92	020-644
DCT 1000	400v	DN65	900/55	7.5	17.5	680 x 279 x 430	96	020-646
DN50 COUNTER FLANGE KIT								M6222221
DN65 COUNTER FLANGE KIT								M6222222

SUBMERSIBLE PUMPS

OLIJU BA GUIDE RAIL KIT-STOOL, CLAW & TOP BRACKET

E

The guide rail facilitates maintenance operations allowing to remove the pump without draining the tank. BA series come with female threads and may require a nipple to connect the pump to the claw depending on the pump model.

Features

2"
2½"
3"

Applications

Heavy Duty
Sewage Vessels

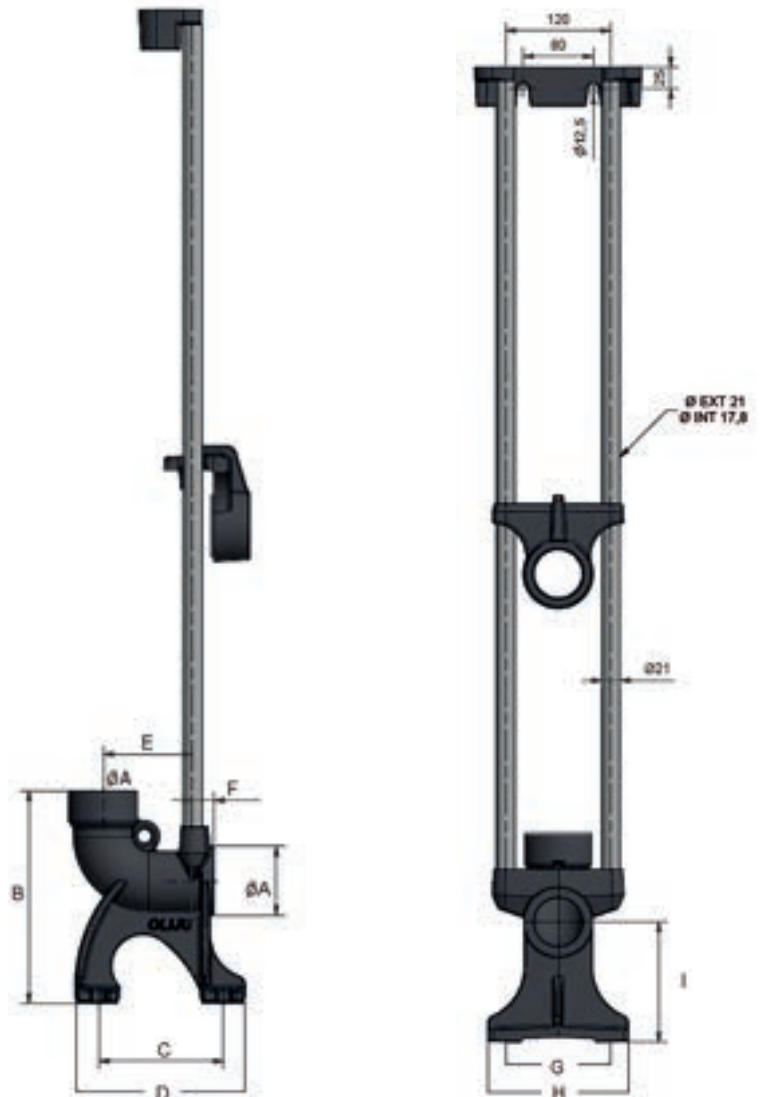

TYPE	DIMENSIONS (mm)								
	ØA	B	C	D	E	F	G	H	I
BA 50	2"	235	140	190	100	63	130	160	135
BA 65	2½"	285	166	220	119	68	150	180	165
BA 80	3"	298	174	229	119	68	180	210	175

MODEL	OUTLET	Kg	CODE
BA 50	2"	9.5	1200-0402
BA 65	2½"	13	1200-0406
BA 80	3"	15	1200-0408
SGR 40 ADAPTER TO SUIT BA50	2"	1.9	1200-0420

SUBMERSIBLE PUMPS

OLIJU SGR SEWAGE GRINDER PUMPS

E

Oliju SGR submersible grinder pumps are suitable for domestic and light commercial sewage waste containing soft solids that the grinding system will shred it into smaller pieces and be pumped to waste. Can be installed free standing or installed with guide rail set ups. Double mechanical silicon seals. Motor casting, pump body and open impeller in cast iron. Stainless steel shaft. Maximum liquid temperature 35°C. 10m power cable for SGR40 and 20m power cable for SGR50. Single phase pumps complete with capacitor/overload box. Maximum immersion depth 10m.

Features

Grinder
High Head

Applications

Waste Water
Domestic Sewage
Light Commercial

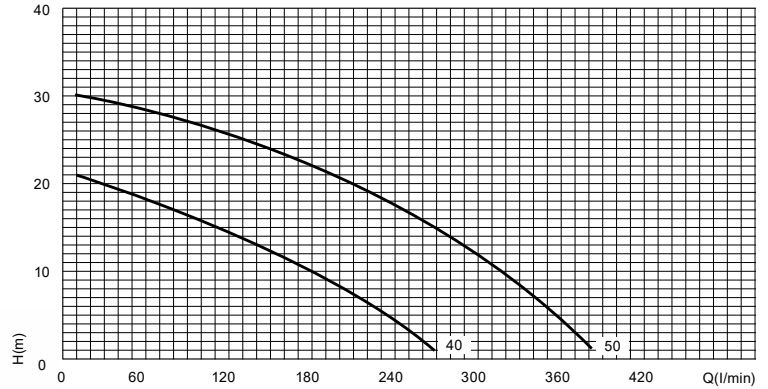

MODEL	VOLT	OUTLET	LM/HM	Kw	AMP	H x W x L mm	Kg	CODE
SGR 40.150 MANUAL	230v	1½"	250/21	1.5	7.2	402 x 238 X 238	26.5	1200-0005
SGR 40.150 AUTO	230v	1½"	250/21	1.5	7.2	402 x 238 X 238	26.5	1200-0010
SGR 50.220 MANUAL	230v	2"	380/30	2.2	10	470 x 288 X 294	36	1200-0015
SGR 50.220 AUTO	230v	2"	380/30	2.2	10	470 x 288 X 294	36	1200-0020
SGR 40.150	400v	2"	250/21	1.5	2.1	402 x 288 X 238	26.5	1200-0025
SGR 50.220	400v	2"	380/30	2.2	4.6	470 x 288 X 294	36	1200-0030
SGR40-BA50 ADAPTER FLANGE	-	2"	-	-	-	-	1.9	1200-0420

SUBMERSIBLE PUMPS

JST/SK CUTTER ALL 316 STAINLESS STEEL PUMPS

A

Precision cast 316 stainless steel drainer pumps. Elastomers and O rings are made from Viton. Side vertical outlet, twin Viton mechanical seals, carbon ceramic and silicon carbide in a lubricated chamber. Complete with 10 metres of power cable. Hose tails are supplied with all models up to and including JST22SKSS. Suitable for effluent waste water, corrosive liquids and chemical sumps, check for compatibility. Single phase pumps can be fitted with MAC-3 floats, allow approx 300mm away from the pump to operate correctly. See pages 78-81 for control panels and 85-89 for float switches.

Features

- S/Steel Pump Body
- S/Steel Impeller
- Max Solids JS750SK JST8SK 21mm
JST15SK, 22SK 44mm
JST37SK 35mm / 55SK & 75SK 60mm

Applications

- Light Chemical Waste
- Heavy Duty
- Clean Water
- Dirty Water
- Sewage



JS750SKSS

JST8SKSS

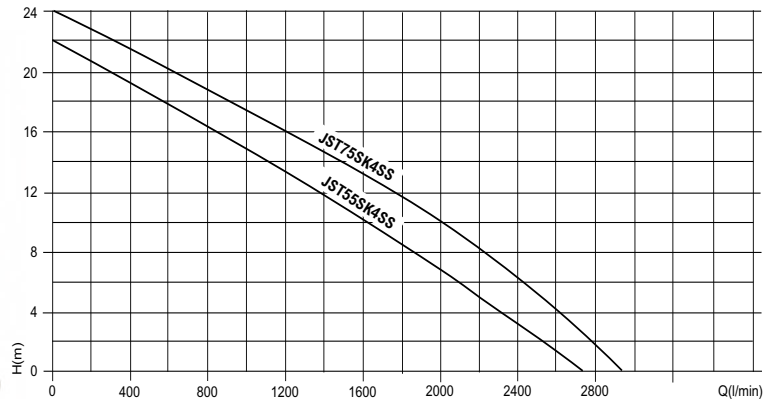
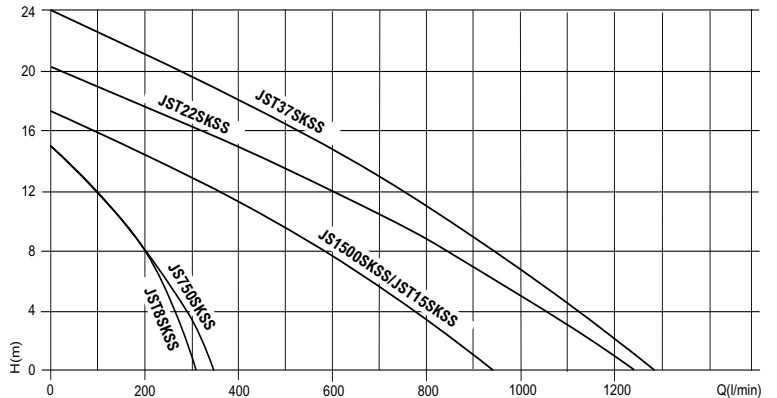

MODEL	VOLT	OUTLET	LM/HM	Kw	AMP	H x W x L mm	Kg	CODE
JS-750SKSS	230v	2"	345/15	0.75	6.8	530 x 195 x 310	29	011-356
JS-1500SKSS	230v	3"	945/17	1.5	12	590 x 240 x 360	36	011-360
JST-8SKSS	400v	2"	310/15	0.75	1.8	465 x 195 x 310	28	011-364
JST-15SKSS	400v	3"	950/17	1.5	3.2	515 x 240 x 360	37	011-370
JST-22SKSS	400v	3"	1250/20	2.2	4.6	560 x 240 x 400	49	011-374
JST-37SKSS	400v	4"	1285/24	3.7	7.9	600 x 245 x 450	55	011-378
JST-55SK4SS	400v	4"	2730/22	5.5	11.5	745 x 400 x 725	150	011-382
JST-75SK4SS	400v	4"	2935/24	7.5	15.2	795 x 400 x 725	165	011-386

COUPLING FOOT, CLAW & TOP BRACKET KITS

MODEL	SIZE	CODE
SR-50SS*	2"	011-390
SR-80SS*	3"	011-394
SR-100SS*	4"	011-398



SR50SS



SR80/100SS

*Subject to design.

SUBMERSIBLE PUMPS

JS/T DRAINER ALL 316 STAINLESS STEEL PUMPS

A

Precision cast 316 stainless steel drainer pumps. Elastomers and O rings are made from Viton. Side vertical outlet, twin Viton mechanical seals, carbon ceramic and silicon carbide in a lubricated chamber. Complete with 10 metres of power cable. Hose tails are supplied with all 2" and 3" models. Suitable for effluent waste water, corrosive liquids and chemical sumps, check for compatibility. Automatic pumps fitted with MAC-3 floats, allow approx 300mm away from the pump to operate correctly. See pages 78-81 for control panels and 88-89 for float switches.

Features

- S/Steel Pump Body
- S/Steel Impeller
- Max Solids 6mm

Applications

- Light Chemical Waste
- Heavy Duty
- Clean Water
- Dirty Water
- Drainage



JS400SS



JST22SS

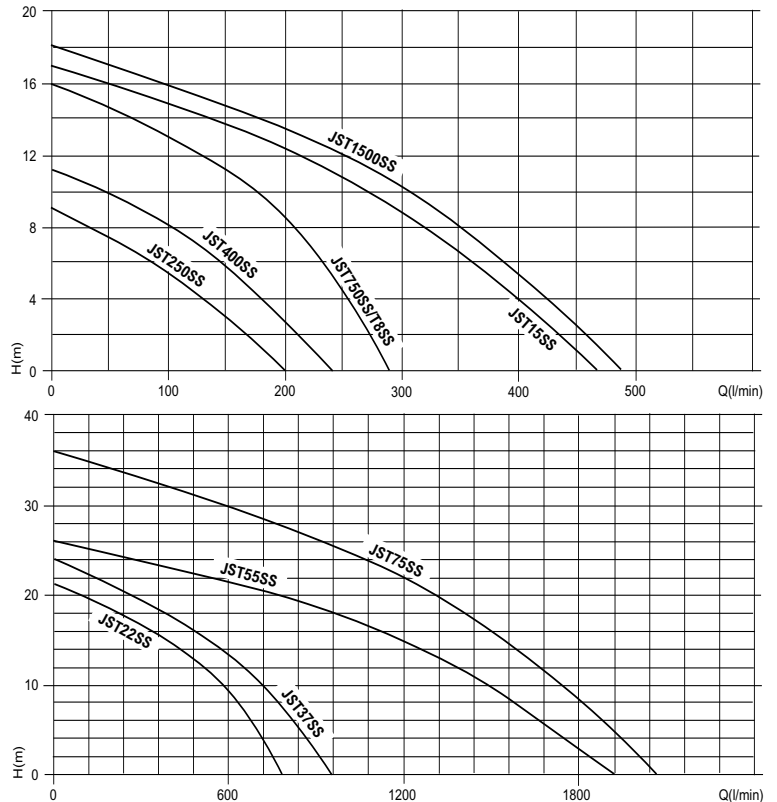

MODEL	VOLT	OUTLET	LM/HM	Kw	AMP	H x W x L mm	Kg	CODE
JS-250SS MANUAL	230v	1½"	200/9.5	0.25	1.9	370 x 150 x 220	12	011-300
JS-250SS MANUAL	110v	1½"	200/9.5	0.25	4	370 x 150 x 220	12	011-304
JS-400SS MANUAL	230v	2"	240/11.5	0.4	3.8	420 x 150 x 220	15	011-308
JS-400SS MANUAL	110v	2"	240/11.5	0.4	7.6	420 x 150 x 220	15	011-312
JS-400SS MANUAL 60Hz	230v	2"	240/11.5	0.4	3.8	420 x 150 x 220	15	011-316
JS-750SS MANUAL	230v	2"	295/16	0.75	6.8	480 x 195 x 255	26	011-320
JS-750SS MANUAL	110v	2"	295/16	0.75	13.0	480 x 195 x 255	26	011-324
JS-1500SS MANUAL	230v	3"	485/18	1.5	12	510 x 195 x 285	32	011-328
JST-8SS	400v	2"	295/16	0.75	1.8	420 x 190 x 310	24	011-332
JST-15SS	400v	3"	465/17.5	1.5	3.2	440 x 190 x 260	28	011-336
JST-22SS	400v	3"	780/21	2.2	4.6	510 x 220 x 315	39	011-340
JST-37SS	400v	4"	965/24	3.7	7.9	525 x 220 x 320	44	011-344
JST-55SS	400v	4"	1920/26	5.5	11.5	640 x 280 x 500	66	011-348
JST-75SS	400v	6"	2065/35.5	7.5	15.2	720 x 280 x 500	76	011-352

JS SINGLE PHASE MODELS CAN BE MODIFIED FOR AUTOMATIC OPERATION

TYPE	CODE
MAC3 (ALL MODELS)	020-001
AGMA*	020-003

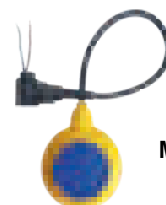

MAC3



AGMA

*Not recommended for JS-750 110v or JS-1500 230v.

SUBMERSIBLE PUMPS

PERFECTA - ACID & ALKALI CORROSION RESISTANT DRAINAGE PUMPS

D

The Perfecta range are designed for chemical resistance against strong acids and alkalis. Compact and portable design for easy handling and installation. Maximum liquid temperature continuous 57 degrees. Intermittent 90 degrees for 20 minutes. 10m power cable. Vertical or horizontal 1 1/4" outlet. 3 models are available for different applications in single phase 230v and 3 phase 400v. Please contact us for a chemical compatibility chart which can advise of the best pump solution for your application

Features

- Corrosion Resistant
- Noryl Pump Body
- Compact & Lightweight

Applications

- Metal Plating Industries
- Chemical
- Marine
- Salt Mining

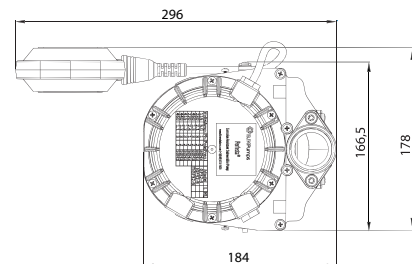
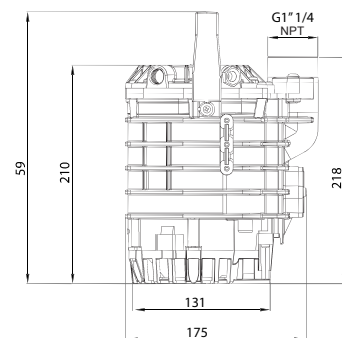
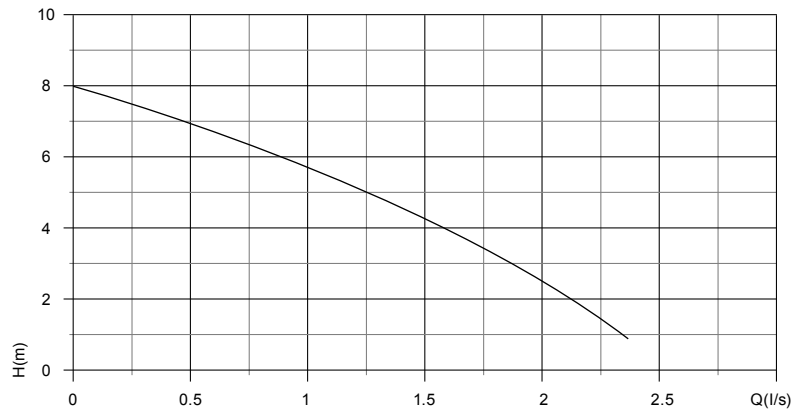

Contact us for more details

MODEL PERFECTA	GF
Materials used in this pump	304 SS
	FKM
	Viton
	BUNA
	PolyProplene
	Noryl
	Neoprene

MODEL PERFECTA	IGF
Materials used in this pump	316 SS
	FKM
	Viton
	PolyProplene
	Noryl
	Neoprene

MODEL PERFECTA	TIGF
Materials used in this pump	Titanium
	FKM
	Viton
	EPDM
	PolyProplene
	Noryl
Neoprene	

SUBMERSIBLE PUMPS

JST KB INDUSTRIAL HEAVY DUTY PUMPS

A

Top outlet providing maximum motor cooling for continuous operation. Built in agitator, specially designed to create a mixing action at the pump inlet causing the solids to move in suspension and to help keep the impeller and flow chamber clear and unclogged. Heavy duty Hi Chromium impeller, diffuser plate and agitator. Male BSP threaded outlets, direct online starting and 20 metres of power cable. 3000 RPM motors. Maximum liquid temperature 40°C.

Features

Cast Iron Pump Body
HICR Impeller
Max Solids 10mm

Applications

Heavy Duty
Sewage
Dirty Water
De watering
Sand/Sludge/Slurry

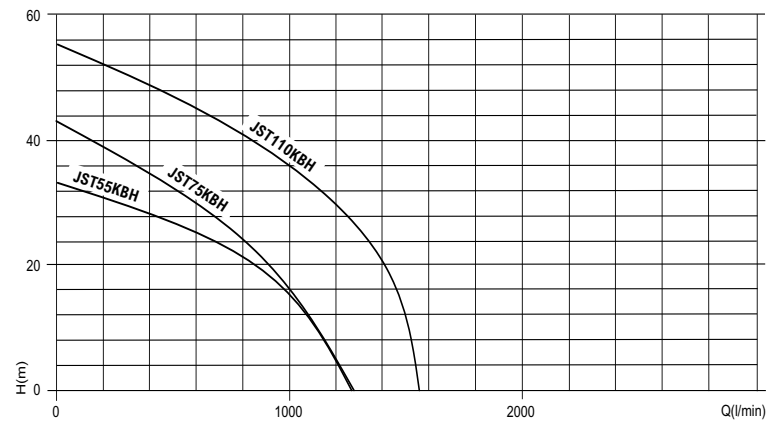
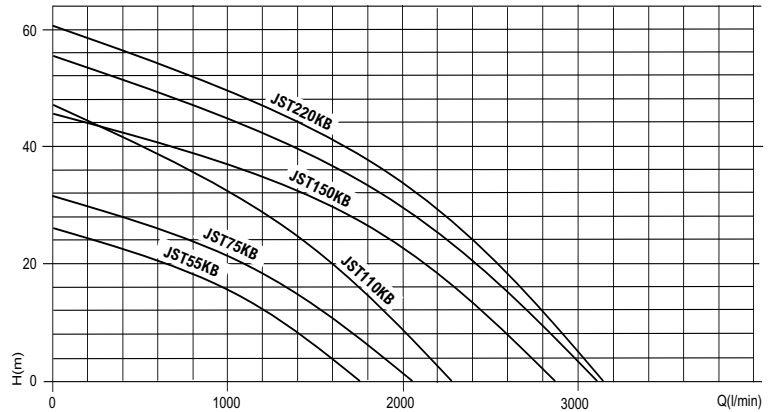

Mining, aggregate, sludge, silt removal, construction dewatering, settling basins, emergency flood water removal

Additional lip seal protection helping to keep impurities away from the mechanical seals. Agitator swirls up solids keeping them in suspension for easier discharge. Abrasive resistant Hi Chromium impeller, wear plate and agitator. In built thermal overload protection. Shaft sleeves at wear points. Double mechanical Seals.

MODEL	VOLT	OUTLET	LM/HM	Kw	AMP	H x W x L mm	Kg	CODE
JST-55 KB	400v	4"	1755/26	5.5	11.5	750 x 345 x 350	120	011-122
JST-55 KBH	400v	3"	1260/33	5.5	11.5	720 x 345 x 350	120	011-124
JST-75 KB	400v	6"	2055/31.5	7.5	15.2	825 x 345 x 370	130	011-126
JST-75 KBH	400v	4"	1265/43	7.5	15.2	795 x 345 x 370	130	011-128
JST-110 KB	400v	6"	2280/47	11	22.7	890 x 345 x 370	150	011-130
JST-110 KBH	400v	4"	1545/55	11	22.7	860 x 345 x 370	150	011-132
JST-150 KB	400v	6"	2870/45.5	15	29.9	1002 x 365 x 540	250	011-134
JST-220 KB	400v	6"	3145/60.5	22	45.5	1002 x 365 x 540	260	011-138

SUBMERSIBLE PUMPS

JST KZN-H/L INDUSTRIAL HEAVY DUTY PUMPS

A

Top outlet providing maximum motor cooling for continuous operation. Built in agitator, specially designed to create a mixing action at the pump causing the solids to move in suspension and to help keep the impeller and flow chamber clear and unclogged. Heavy duty Hi Chromium impeller, diffuser plate and agitator. Male BSP threaded outlets, direct online starting and 20 metres of power cable. 1500 RPM motors. Twin silicon mechanical seals. Maximum liquid temperature 40°C.

Features

- Cast Iron Pump Body
- HICR Impeller
- Max Solids JST55-75KZNH 25mm
JST110KZNH-JST220KZNL 35mm

Applications

- Heavy Duty
- Sewage
- Dirty Water
- De watering
- Sand/Sludge/Slurry

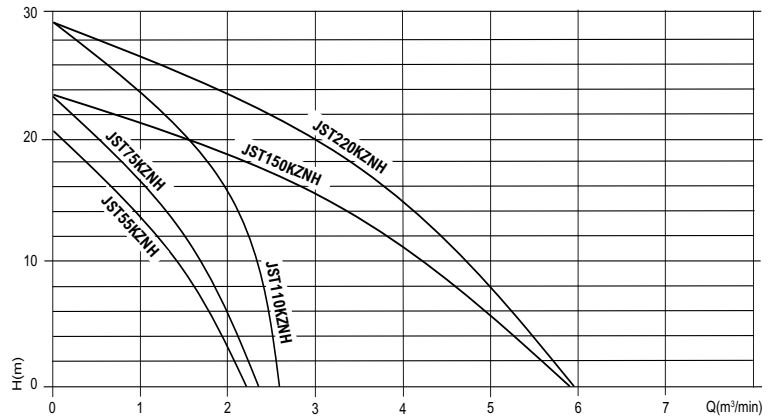

Mining, aggregate, sludge, silt removal, construction dewatering, settling basins, emergency flood water removal

Additional lip seal protection helping to keep impurities away from the mechanical seals. Agitator swirls up solids keeping them in suspension for easier discharge. Abrasive resistant Hi Chromium impeller, wear plate and agitator. In built thermal overload protection. Shaft sleeves at wear points. Double mechanical Seals.



MODEL	VOLT	OUTLET	LM/HM	Kw	AMP	H x W x L mm	Kg	CODE
JST-55 KZN-H	400v	3"	2205/20.5	5.5	11.5	820 x 410 x 420	150	011-088
JST-75 KZN-H	400v	4"	2345/23.5	7.5	15.2	840 x 410 x 420	170	011-096
JST-110 KZN-H	400v	4"	2585/29	11	22.7	1100 x 565 x 585	280	011-098
JST-150 KZN-L	400v	6"	5910/23.5	15	29.9	1100 x 565 x 585	285	011-118
JST-220 KZN-L	400v	8"	5960/29	22	45.5	1493 x 560 x 578	470	011-120

SUBMERSIBLE PUMPS

JST KZN INDUSTRIAL HEAVY DUTY PUMPS

A

Top outlet providing maximum motor cooling for continuous operation. Built in agitator, specially designed to create a mixing action at the pump inlet causing the solids to move in suspension and to help keep the impeller and flow chamber clear and unclogged. Heavy duty Hi Chromium impeller, diffuser plate and agitator. Male BSP threaded outlets, direct online starting and 20 metres of power cable. 1500 RPM motors. Maximum liquid temperature 40°C.

Features

- Cast Iron Pump Body
- HICR Impeller
- Max Solids JST37KZN 20mm /
JST55&75KZN 25mm
JST110 220KZN 35mm

Applications

- Heavy Duty
- Sewage
- Dirty Water
- De watering
- Sand/Sludge/Slurry

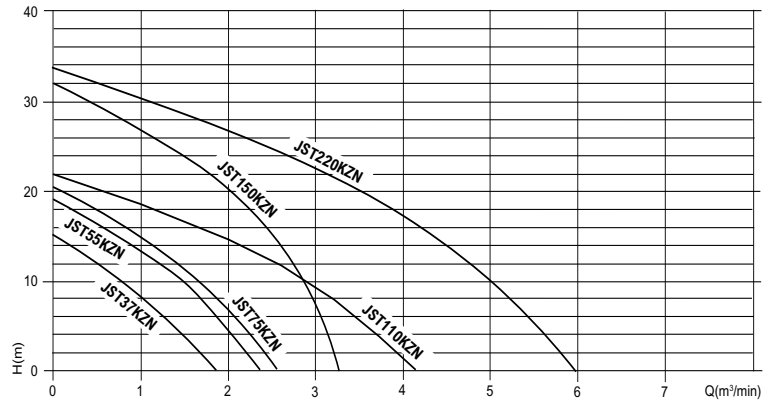

Mining, aggregate, sludge, silt removal, construction dewatering, settling basins, emergency flood water removal

Additional lip seal protection helping to keep impurities away from the mechanical seals. Agitator swirls up solids keeping them in suspension for easier discharge. Abrasive resistant Hi Chromium impeller, wear plate and agitator. In built thermal overload protection. Shaft sleeves at wear points. Double mechanical Seals.



MODEL	VOLT	OUTLET	LM/HM	Kw	AMP	H x W x L mm	Kg	CODE
JST-37 KZN	400v	3"	1730/15.5	3.7	7.9	820 x 410 x 420	135	011-091
JST-55 KZN	400v	4"	2430/19	5.5	11.5	820 x 410 x 420	145	011-093
JST-75 KZN	400v	4"	2570/20.5	7.5	15.2	840 x 410 x 420	165	011-095
JST-110 KZN	400v	6"	4135/22	11	22.7	1100 x 560 x 570	275	011-097
JST-150 KZN	400v	6"	3305/32	15	29.9	1100 x 560 x 570	285	011-114
JST-220 KZN	400v	6"	5960/33.5	22	45.5	1493 x 560 x 578	470	011-116

SUBMERSIBLE PUMPS

DRENO

Dreno Pompe brand was established in 1990 and mainly produced pumps exclusively for sewage discharge. In 2002 a wider range of pumps were designed and produced up to 45 kW. The company was distinguished by its advanced technology and quality. Between 2009 and 2012 Dreno obtained its first ATEX certificates and began expanding into new markets. By 2014 Dreno was awarded the ATEX/IECEx certificate which was extended up to 90% of the product range. In 2018 the range now extends to pumps with DN200 output.

Submersible pumps with Vortex Impeller are used to pump sewage with suspended solids. Suitable for domestic, industrial and farming applications.



Submersible pumps with Double Channel Impellers S-Flow are used to pump waste water in treatment plants, sewage processing in industrial and domestic applications.



Submersible pumps with Open Single Channel Impeller are used to pump waste water including sewage and includes a cutter built into the impeller.



Submersible pumps with Closed Single Channel Impellers used to pump waste water and sewage. Wide channels.



Submersible pumps with Double Channel Centrifugal Impellers are used to pump large volumes of waste water including light sewage at high pressure.



Submersible Grinder pumps have an inbuilt macerator on the inlet of the pump. This breaks down soft solids in the water to be pumped to waste.



DRENO

Dreno installation examples



Dreno construction





MODEL	EASY B GUIDE RAIL COUPLING FOOT, CLAW & TOP BRACKET
COMPATTA 22	✓
COMPATTA 32	✓
COMPATTA 4	✓
COMPATTA 5	✓
CODE	200-0432

SUBMERSIBLE PUMPS

DRENO COMPATTA VORTEX PUMPS

E

The main components are fabricated in cast iron GG20, in the standard configuration a lip seal is fitted to the motor side, and a mechanical seal to the impeller side. The Compatta Series is ideal to pump residential sewage thanks to its small size and mechanical characteristics. Maximum liquid temperature 40°C. Maximum depth of immersion 20 metres. Power cable 10 metres. Many of the Dreno pump ranges are available ATEX approved. More models continue on the following pages.

Features

- Cast Iron Pump Body
- Cast Iron Impeller
- Max Solids 22/32 Series 40mm
- 4/55 Series 50mm

Applications

- Heavy Duty
- Sewage
- Dirty Water



MODEL	VOLT	OUTLET	LM/HM	Kw	AMP	H x W x L mm	Kg	CODE
COMPATTA 22M MANUAL	230v	2"	420/8	0.56	3.6	400x175x225	15	200-0020
COMPATTA 22T MANUAL	400v	2"	420/8	0.56	1.7	400x175x225	15	200-0022
COMPATTA 22TG AUTO	400v	2"	420/8	0.56	1.7	400x175x225	15	200-0023
COMPATTA 32M MANUAL	230v	2"	480/10	0.75	5.2	399x175x225	17	200-0026
COMPATTA 32T MANUAL	400v	2"	480/10	0.75	1.9	399x175x225	17	200-0028
COMPATTA 32TG AUTO	400v	2"	480/10	0.75	1.9	399x175x225	17	200-0029
COMPATTA 4M MANUAL	230v	2"	510/13	1.1	7.6	444x176x226	19	200-0032
COMPATTA 4T MANUAL	400v	2"	510/13	1.1	2.9	444x176x226	19	200-0034
COMPATTA 4TG AUTO	400v	2"	510/13	1.1	2.9	444x176x226	19	200-0031
COMPATTA 55MG AUTO	230v	2"	540/15	1.5	9.9	444x176x226	21	200-0035
COMPATTA 55TG AUTO	400v	2"	540/15	1.5	3.9	444x176x226	21	200-0039



MODEL	EASY B GUIDE RAIL COUPLING FOOT, CLAW & TOP BRACKET
COMPATTA PRO 50-2/060	✓
COMPATTA PRO 50-2/080	✓
COMPATTA PRO 50-2/110	✓
COMPATTA PRO 50-2/150	✓
COMPATTA PRO 50-2/220	✓
CODE	200-0432

SUBMERSIBLE PUMPS

DRENO COMPATTA PRO VORTEX PUMPS

E

The main components are fabricated in cast iron GG20, in the standard configuration a lip seal is fitted to the motor side, and a mechanical seal to the impeller side. The Compatta PRO Series is ideal to pump sewage and waste tanks to its small size and mechanical characteristics. The pumps with EX can be used in potentially explosive environments. Maximum liquid temperature 40°C. Maximum depth of immersion 20 metres. Power cable 10 metres.

Features

Cast Iron Pump Body
Cast Iron Impeller
Max Solids 50mm

Applications

Heavy Duty
Sewage
Dirty Water

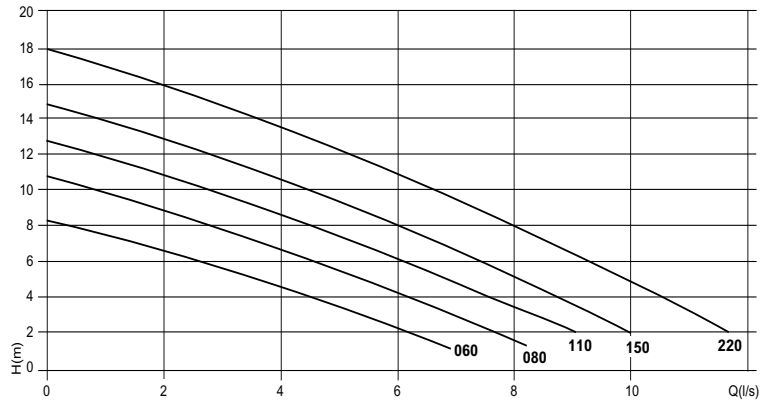

II 2G
Ex db IIB T4 Gb
EX h IIB T4 Gb
0° ≤ Ta ≤ 40°

MODEL	VOLT	OUTLET	LM/HM	Kw	AMP	H x W x L mm	Kg	CODE
COMPATTA PRO 50-2/150 M	230v	2"	420/8	1.5	9.6	409x186x240	25	200-0038
COMPATTA PRO 50-2/220 T	400v	2"	420/8	2.2	5.2	409x186x240	25	200-0040
COMPATTA PRO 50-2/150 T	400v	2"	420/8	1.5	3.7	409x186x240	25	200-0540
COMPATTA PRO-EX 50-2/060 M	230v	2"	480/10	0.6	4.8	400x175x225	24	200-0020EX
COMPATTA PRO-EX 50-2/060 T	400v	2"	480/10	0.6	2.1	400x175x225	24	200-0022EX
COMPATTA PRO-EX 50-2/080 M	230v	2"	480/10	0.8	5.8	399x175x225	24	200-0026EX
COMPATTA PRO-EX 50-2/080 T	400v	2"	510/13	0.8	2.4	399x175x225	24	200-0028EX
COMPATTA PRO-EX 50-2/110 M	230v	2"	510/13	1.1	7.4	444x176x226	24	200-0032EX
COMPATTA PRO-EX 50-2/110 T	400v	2"	510/13	1.1	2.9	444x176x226	24	200-0034EX
COMPATTA PRO-EX 50-2/150 M	230v	2"	540/15	1.5	9.6	409x186x240	25	200-0038EX
COMPATTA PRO-EX 50-2/150 T	400v	2"	540/15	1.5	3.7	409x186x240	25	200-0540EX
COMPATTA PRO-EX 50-2/220 T	400v	2"	540/18	2.2	5.2	409x186x240	25	200-0040EX

DRENO DNA VORTEX 2"

E

The main components are fabricated in cast iron GG20. The Double mechanical seal in a back to back configuration located in the oil chamber guarantee long durability to the product. The DNA Series is used for sewage and waste water. Its wide channel permits the free passage of solids rendering it particularly useful in water treatment plants, domestic, municipal and farming applications. Complete with 10 metres of power cable. Maximum liquid 40°C. Maximum immersion 20 metres. Model DNA 50 has two outlet options. 2" BSP female thread and DN50 flange.

Features

- Cast Iron Pump Body
- Cast Iron Impeller
- Max Solids 50mm

Applications

- Heavy Duty
- Sewage

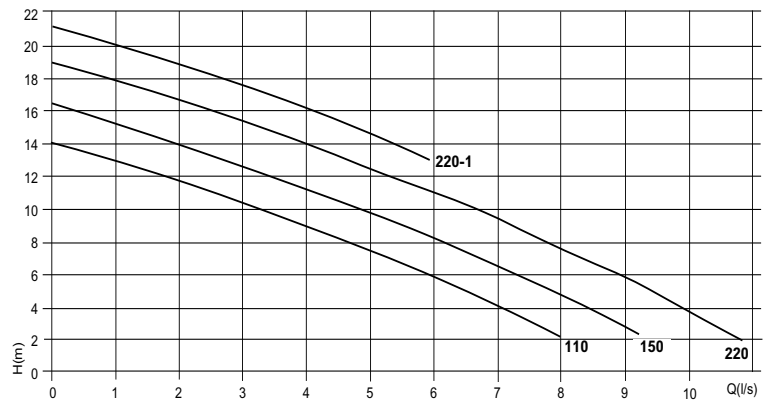

II 2G
Ex db IIB T4 Gb
EX h IIB T4 Gb
 $0^{\circ} \leq T_a \leq 40^{\circ}$

MODEL	VOLT	OUTLET	LM/HM	Kw	AMP	H x W x L mm	Kg	CODE
DNA 50-2/110 M	230v	2"/DN50	480/14	1.1	7.8	386 x 217 x 264	28	200-1410
DNA 50-2/110 M EX	230v	2"/DN50	480/14	1.1	7.8	386 x 217 x 264	28	200-1410EX
DNA 50-2/150 M	230v	2"/DN50	540/16	1.5	9.9	386 x 217 x 264	29	200-1418
DNA 50-2/150 M EX	230v	2"/DN50	540/16	1.5	9.9	386 x 217 x 264	29	200-1418EX
DNA 50-2/110 T	400v	2"/DN50	480/14	1.1	2.9	386 x 217 x 264	28	200-1414
DNA 50-2/110 T EX	400v	2"/DN50	480/14	1.1	2.9	386 x 217 x 264	28	200-1414EX
DNA 50-2/150 T	400v	2"/DN50	540/16	1.5	3.6	386 x 217 x 264	29	200-1422
DNA 50-2/150 T EX	400v	2"/DN50	540/16	1.5	3.6	386 x 217 x 264	29	200-1422EX
DNA 50-2/220 T	400v	2"/DN50	640/19	2.2	5.3	386 x 217 x 264	30	200-1426
DNA 50-2/220 T EX	400v	2"/DN50	640/19	2.2	5.3	386 x 217 x 264	30	200-1426EX
DNA 50-2/220-1 T	400v	2"/DN50	350/21	2.2	5.3	411 x 217 x 264	30	200-1428
DNA 50-2/220-1 T EX	400v	2"/DN50	350/21	2.2	5.3	411 x 217 x 264	30	200-1428EX

DRENO DNA VORTEX 2½”

E

The main components are fabricated in cast iron GG20. The Double mechanical seal in a back to back configuration located in the oil chamber guarantee long durability to the product. The DNA Series is used for sewage and waste water. Its wide channel permits the free passage of solids rendering it particularly useful in water treatment plants, domestic, municipal and farming applications. Complete with 10 metres of power cable.

Features

Cast Iron Pump Body
Cast Iron Impeller
Max Solids 65mm

Applications

Heavy Duty
Sewage

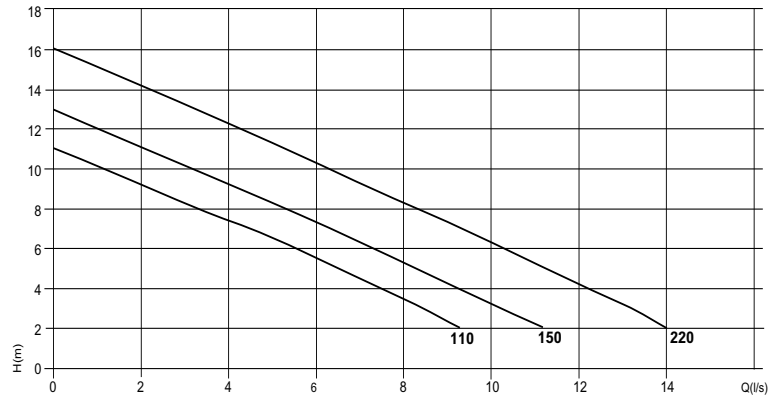

II 2G
Ex db IIB T4 Gb
EX h IIB T4 Gb
0° ≤ Ta ≤ 40°

MODEL	VOLT	OUTLET	LM/HM	Kw	AMP	H x W x L mm	Kg	CODE
DNA 65-2/110 M	230v	DN65	540/11	1.1	7.4	411 x 223 x 270	28	200-0805
DNA 65-2/110 M EX	230v	DN65	540/11	1.1	7.4	411 x 223 x 270	28	200-0805EX
DNA 65-2/150 M	230v	DN65	660/13	1.5	9.9	411 x 223 x 270	30	200-0825
DNA 65-2/150 M EX	230v	DN65	660/13	1.5	9.9	411 x 223 x 270	30	200-0825EX
DNA 65-2/110 T	400v	DN65	540/11	1.1	2.7	411 x 223 x 270	28	200-0815
DNA 65-2/110 T EX	400v	DN65	540/11	1.1	2.7	411 x 223 x 270	28	200-0815EX
DNA 65-2/150 T	400v	DN65	660/13	1.5	3.4	411 x 223 x 270	30	200-0835
DNA 65-2/150 T EX	400v	DN65	660/13	1.5	3.4	411 x 223 x 270	30	200-0835EX
DNA 65-2/220 T	400v	DN65	840/16	2.2	5.2	520 x 223 x 270	30.5	200-0855
DNA 65-2/220 T EX	400v	DN65	840/16	2.2	5.2	520 x 223 x 270	30.5	200-0855EX



MODEL	GUIDE RAIL COUPLING FOOT, CLAW & TOP BRACKET DUTY 50	GUIDE RAIL COUPLING, FOOT, CLAW & TOP BRACKET DUTY 65	GUIDE RAIL COUPLING, FOOT, CLAW & TOP BRACKET DUTY 80	THREADED FLANGE DN50 KIT	THREADED FLANGE DN65 KIT	THREADED FLANGE DN80 KIT
DNA 50-2/110 M	✓			✓		
DNA 50-2/150 M	✓			✓		
DNA 50-2/220 T	✓			✓		
DNA 65-2/110 M		✓			✓	
DNA 65-2/150 M		✓			✓	
DNA 65-2/220 T EX		✓			✓	
DNA 80-2/110 T EX			✓			✓
DNA 80-2/150 T EX			✓			✓
DNA 80-2-220 T EX			✓			✓
DNA 80-4/090 M			✓			✓
CODE	200-0434	200-0435	200-0436	M62222221	M62222222	M62222223

DRENO DNA VORTEX 3''

E

The main components are fabricated in cast iron GG20. The Double mechanical seal in a back to back configuration located in the oil chamber guarantees long durability to the product. The DNA Series is used for sewage and waste water. Its wide channel permits the free passage of solids rendering it particularly useful in water treatment plants, domestic, municipal and farming applications. Complete with 10 metres of power cable. Maximum liquid 40°C . Maximum immersion 20m.

Features

Cast Iron Pump Body
Cast Iron Impeller
Max Solids 80mm

Applications

Heavy Duty
Sewage

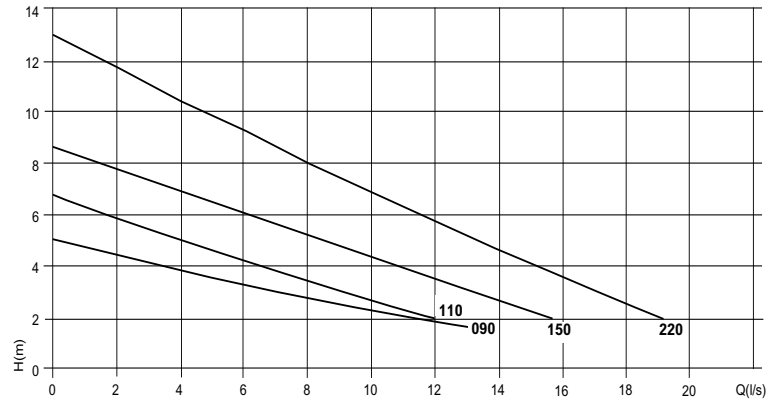

II 2G
Ex db IIB T4 Gb
EX h IIB T4 Gb
0° ≤ Ta ≤ 40°

MODEL	VOLT	OUTLET	LM/HM	Kw	AMP	H x W x L mm	Kg	CODE
DNA 80-2/110 M	230v	DN80	720/6.5	1.1	7.4	488 x 249 x 295	32	200-0905
DNA 80-2/110 M EX	230v	DN80	720/6.5	1.1	7.4	488 x 249 x 295	32	200-0905EX
DNA 80-2/110 T	400v	DN80	720/6.5	1.1	2.8	488 x 249 x 295	32	200-0915
DNA 80-2/110 T EX	400v	DN80	720/6.5	1.1	2.8	488 x 249 x 295	32	200-0915EX
DNA 80-2/150 M	230v	DN80	900/8.5	1.5	9.9	488 x 249 x 295	35	200-0925
DNA 80-2/150 M EX	230v	DN80	900/8.5	1.5	9.9	488 x 249 x 295	35	200-0925EX
DNA 80-2/150 T	400v	DN80	900/8.5	1.5	3.6	488 x 249 x 295	35	200-0935
DNA 80-2/150 T EX	400v	DN80	900/8.5	1.5	3.6	488 x 249 x 295	35	200-0935EX
DNA 80-2/220 T	400v	DN80	1140/13	2.2	5.3	513 x 249 x 295	35	200-0955
DNA 80-2/220 T EX	400v	DN80	1140/13	2.2	5.3	513 x 249 x 295	35	200-0955EX
DNA 80-4/090 M	230v	DN80	780/5	0.9	4.7	488 x 249 x 295	38	200-1005
DNA 80-4/090 M EX	230v	DN80	780/5	0.9	4.7	488 x 249 x 295	38	200-1005EX
DNA 80-4/090 T	400v	DN80	780/5	0.9	2.6	488 x 249 x 295	38	200-1015
DNA 80-4/090 T EX	400v	DN80	780/5	0.9	2.6	488 x 249 x 295	38	200-1015EX



MODEL	GUIDE RAIL COUPLING FOOT, CLAW & TOP BRACKET	FREE STANDING BASE P4	FREE STANDING BASE P5	THREADED FLANGE DN80 KIT
AT80-C.246	✓	✓		✓
AT80-C.247	✓	✓		✓
AT80-C.254	✓		✓	✓
AT80-C.257	✓		✓	✓
AT80-C.259	✓		✓	✓
CODE	100-11510	100-11625	100-11626	M62222223

SUBMERSIBLE PUMPS

DRENO – AT SINGLE CHANNEL IMPELLER (2 POLE)

E

All main components are made of grey cast iron GG25. Two individual mechanical seals (motor side in the oil chamber, impeller side in contact with the liquid). The A2 poles Series is used in pumping and draining clear liquids and sewage. High performance renders it useful in a variety of applications: water treatment plants, industrial plants, farms and sewers. The A series is fitted with open single channel and highly efficient impellers. The shredding system ensures a high degree of reliability even in presence of fibrous materials and solids in suspension. Maximum liquid temperature 40°C. Maximum immersion 20 metres. Complete with 10 metres power cable.

Features

- Cast Iron Pump Body
- Cast Iron Impeller
- Max Solids C.246 C.247 45mm
 - C.254 C.257 60mm
 - C.259 65mm

Applications

- Heavy Duty
- Sewage
- Dirty Water

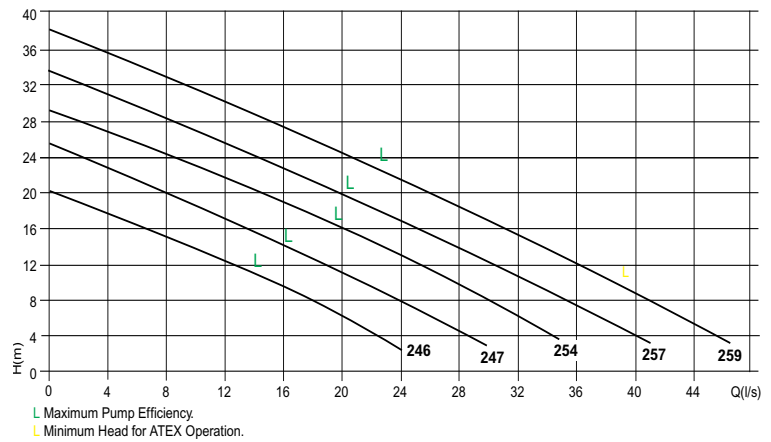

II 2G
Ex db IIB T4 Gb
EX h IIB T4 Gb
 0° ≤ Ta ≤ 40°

MODEL	VOLT	OUTLET	LM/HM	Kw	AMP	H x W x L mm	Kg	CODE
AT80-C.246	400v	DN80	1440/20	3	7.1	528 x 244 x 340	60	200-0115
AT80-C.246 EX	400v	DN80	1440/20	3	7.1	528 x 244 x 340	60	200-0115EX
AT80-C.247	400v	DN80	1800/26	4	9	528 x 244 x 340	60	200-0113
AT80-C.247 EX	400v	DN80	1800/26	4	9	528 x 244 x 340	60	200-0113EX
AT80-C.254	400v	DN80	2160/29	5.5	11.5	608 x 244 x 340	84	200-0109
AT80-C.254 EX	400v	DN80	2160/29	5.5	11.5	608 x 244 x 340	84	200-0109EX
AT80-C.257	400v	DN80	2520/34	7.5	14.5	608 x 244 x 368	88	200-0118
AT80-C.257 EX	400v	DN80	2520/34	7.5	14.5	608 x 244 x 368	88	200-0118EX
AT80-C.259	400v	DN80	2760/38	9	18.5	608 x 244 x 368	90	200-0135
AT80-C.259 EX	400v	DN80	2760/38	9	18.5	608 x 244 x 368	90	200-0135EX



MODEL	B5 GUIDE RAIL COUPLING, FOOT, CLAW AND TOP BRACKET	FREE STANDING BASE P7	THREADED FLANGE DN80 KIT
ATH 80-2/120	✓	✓	✓
ATH 80-2/150	✓	✓	✓
ATH 80-2/200	✓	✓	✓
ATH 80-2/250	✓	✓	✓
ATH 80-2/300	✓	✓	✓
CODE	100-11510	100-11628	M62222223

DRENO ATH TWIN CHANNEL IMPELLER (2 POLE)

E

All main components are made of grey cast iron GG25. Two individual mechanical seals, motor side in the oil chamber, impeller side in contact with the liquid) and high quality parts, ensure the perfect functioning and reliability of the product. The A 2 poles Series is used in pumping and draining clear liquids and sewage. High performance renders it useful in a variety of applications, water treatment plants, industrial plants, farms and sewers. The A series is fitted with open single channel and highly efficient impellers. The shredding system ensures a high degree of reliability even in presence of fibrous materials and solids in suspension. Maximum 40°C liquid temperature. Maximum immersion 20 metres. Complete with 10 metres of power cable.

Features

- Cast Iron Pump Body
- Cast Iron Impeller
- Max Solids 120/150 33mm
200/250/300 40mm

Applications

- Heavy Duty
- Sewage
- Dirty Water

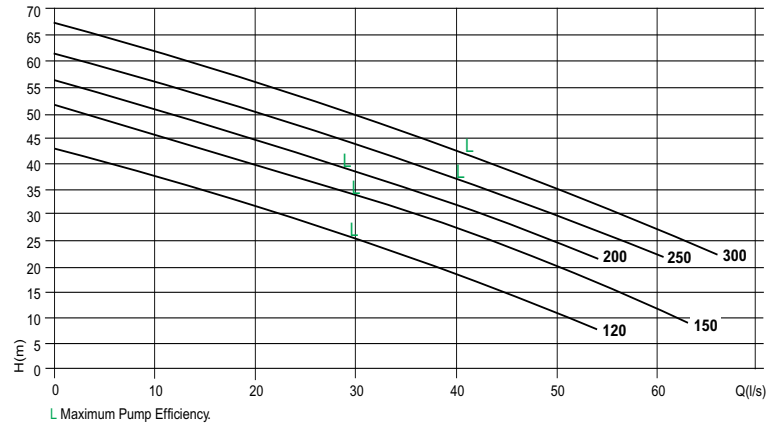

II 2G
Ex db IIB T4 Gb
EX h IIB T4 Gb
 0° ≤ Ta ≤ 40°

MODEL	VOLT	OUTLET	LM/HM	Kw	AMP	H x W x L mm	Kg	CODE
ATH 80-2/120	400v	DN80	3240/41	12	23	700 x 364 x 507	190	200-0124
ATH 80-2/120 EX	400v	DN80	3240/41	12	23	700 x 364 x 507	190	200-0124EX
ATH 80-2/150	400v	DN80	3720/49	15	29.4	700 x 364 x 507	200	200-0126
ATH 80-2/150 EX	400v	DN80	3720/49	15	29.4	700 x 364 x 507	200	200-0126EX
ATH 80-2/200	400v	DN80	3240/55	20	41.2	741 x 364 x 507	247	200-0123
ATH 80-2/200 EX	400v	DN80	3240/55	20	41.2	741 x 364 x 507	247	200-0123EX
ATH 80-2/250	400v	DN80	3600/60	25	48.4	741 x 364 x 532	250	200-0125
ATH 80-2/250 EX	400v	DN80	3600/60	25	48.4	741 x 364 x 532	250	200-0125EX
ATH 80-2/300	400v	DN80	3900/62	30	54.4	808 x 364 x 531	393	200-0127
ATH 80-2/300 EX	400v	DN80	3900/62	30	54.4	808 x 364 x 531	393	200-0127EX



MODEL	B5 GUIDE RAIL COUPLING, FOOT CLAW & TOP BRACKET	FREE STANDING BASE P5	THREADED FLANGE DN80 KIT
AM 80-C.242	✓	✓	✓
AT 80-C.242	✓	✓	✓
AT 80-C.244	✓	✓	✓
AT 80-C.245	✓	✓	✓
CODE	100-11510	100-11626	M62222223

DRENO AM/AT SINGLE CHANNEL OPEN IMPELLER (4 POLE)

E

All main components are made of grey cast iron GG25. Two individual mechanical seals (motor side in the oil chamber, impeller side in contact with the liquid) and high quality parts, ensure the perfect functioning and reliability of the product. The A 4 poles Series is used to pump clear liquids and sewage. The wide range and high hydraulic efficiency renders this series particularly suited to water treatment plants, sewers, farming and industrial plants including in airports, underground public transport, hospitals and hotels. The A series is fitted with open single channel and highly efficient impellers. The shredding system ensures a high degree of reliability even in presence of fibrous materials and solids in suspension. Maximum 40°C liquid temperature. Maximum immersion 20 metres. Complete with 10 metres of power cable.

Features

- Cast Iron Pump Body
- Cast Iron Impeller
- Twin Mechanical Seals
- Max Solids 75mm

Applications

- Heavy Duty
- Sewage
- Dirty Water

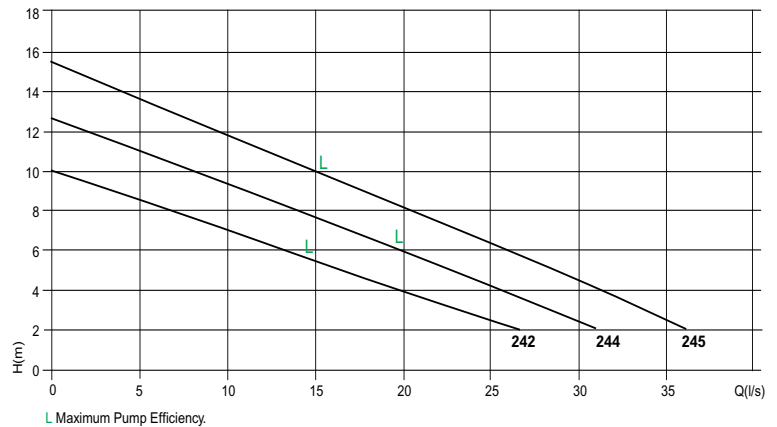

II 2G
Ex db IIB T4 Gb
EX h IIB T4 Gb
0° ≤ Ta ≤ 40°

MODEL	VOLT	OUTLET	LM/HM	Kw	AMP	H x W x L mm	Kg	CODE
AM 80-C.242	230v	DN80	1500/10	1.5	10	432 x 309 x 397	56	200-0138
AM 80-C.242 EX	230v	DN80	1500/10	1.5	10	432 x 309 x 397	56	200-0138EX
AT 80-C.242	400v	DN80	1500/10	1.5	3.8	432 x 309 x 397	56	200-0136
AT 80-C.242 EX	400v	DN80	1500/10	1.5	3.8	432 x 309 x 397	56	200-0136EX
AT 80-C.244	400v	DN80	1860/12	2.2	5.2	432 x 323 x 397	69	200-0150
AT 80-C.244 EX	400v	DN80	1860/12	2.2	5.2	432 x 323 x 397	69	200-0150EX
AT 80-C.245	400v	DN80	2160/15	3.0	7.2	432 x 323 x 397	70	200-0152
AT 80-C.245 EX	400v	DN80	2160/15	3.0	7.2	432 x 323 x 397	70	200-0152EX



MODEL	B6 GUIDE RAIL COUPLING, FOOT CLAW & TOP BRACKET	FREE STANDING BASE P6	THREADED FLANGE DN100 KIT
AT 100-C.243	✓	✓	✓
AT 100-C.244	✓	✓	✓
AT 100-C.245	✓	✓	✓
AT 100-C.255	✓	✓	✓
AT 100-C.256	✓	✓	✓
CODE	100-11511	100-11627	M62222224

DRENO AM/AT SINGLE CHANNEL OPEN IMPELLER (4 POLE)

E

All main components are made of grey cast iron GG25. Two individual mechanical seals (motor side in the oil chamber, impeller side in contact with the liquid) and high quality parts, ensure the perfect functioning and reliability of the product. The A 4 poles Series is used to pump clear liquids and sewage. The wide range and high hydraulic efficiency renders this series particularly suited to water treatment plants, sewers, farming and industrial plants including in airports, underground public transport, hospitals and hotels. The A series is fitted with open single channel and highly efficient impellers. The shredding system ensures a high degree of reliability even in presence of fibrous materials and solids in suspension. Maximum 40°C liquid temperature. Maximum immersion 20 metres. Complete with 10 metres of power cable.

Features

Cast Iron Pump Body
 Cast Iron Impeller
 Twin Mechanical Seals
 Max Solids 243/244/245 75mm
 255/256 90mm

Applications

Heavy Duty
 Sewage
 Dirty Water

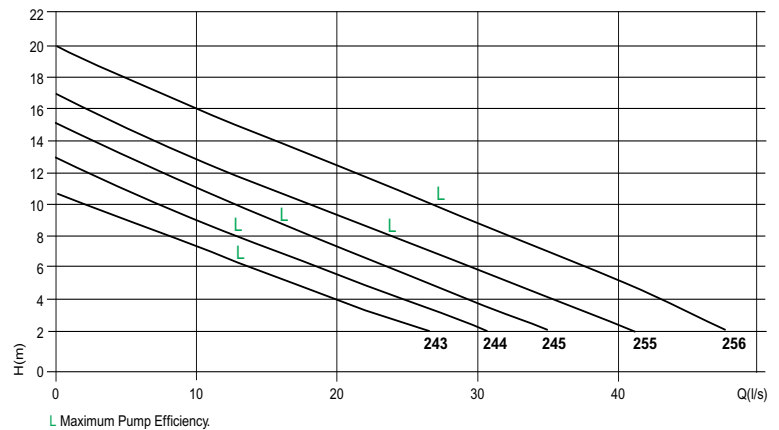

II 2G
Ex db IIB T4 Gb
EX h IIB T4 Gb
 0° ≤ Ta ≤ 40°

MODEL	VOLT	OUTLET	LM/HM	Kw	AMP	H x W x L mm	Kg	CODE
AT 100-C.243	400v	DN100	1560/10	1.7	3.9	507 x 337 x 405	72	200-0160
AT 100-C.243EX	400v	DN100	1560/10	1.7	3.9	507 x 337 x 405	72	200-0160EX
AT 100-C.244	400v	DN100	1800/13	2.2	5.1	507 x 337 x 405	74	200-0162
AT 100-C.244 EX	400v	DN100	1800/13	2.2	5.1	507 x 337 x 405	74	200-0162EX
AT 100-C.245	400v	DN100	2100/15	3.0	7.0	507 x 337 x 405	75	200-0164
AT 100-C.245 EX	400v	DN100	2100/15	3.0	7.0	507 x 337 x 405	75	200-0164EX
AT 100-C.255	400v	DN100	2460/16	4.0	9.1	550 x 375 x 450	97	200-0170
AT 100-C.255EX	400v	DN100	2460/15	4.0	9.1	550 x 375 x 450	97	200-0170EX
AT 100-C.256	400v	DN100	2760/20	5.5	11.5	550 x 375 x 450	103	200-0172
AT 100-C.256EX	400v	DN100	2760/20	5.5	11.5	550 x 375 x 450	103	200-0172EX



MODEL	GUIDE RAIL COUPLING, FOOT, CLAW & TOP BRACKET	FREE STANDING BASE P4	FREE STANDING BASE P5	THREADED FLANGE DN80 KIT
VT 80-C.346	✓	✓		✓
VT 80-C.347	✓	✓		✓
VT 80-C.354	✓		✓	✓
VT 80-C.357	✓		✓	✓
VT 80-C.359	✓		✓	M6222223
CODE	100-11510	100-11628	100-11626	

DRENO VT VORTEX IMPELLER (2 POLE)

E

All main components are made of grey cast iron GG25. Two individual mechanical seals (motor side in the oil chamber, impeller side in contact with the liquid) and high quality parts, ensure the perfect functioning and reliability of the product. The V 2 poles Series is used for pumping sewage with suspended solids. High performance renders it useful in a variety of applications including water treatment plants, industrial plants, farming and sewage. Vortex Impellers give ample solids handling. Maximum 40°C liquid temperature. Maximum immersion 20 metres. Complete with 10 metres of power cable.

Features

- Cast Iron Pump Body
- Cast Iron Impeller
- Max Solids 346/347 60mm
354//357/359 70mm

Applications

- Heavy Duty
- Sewage
- Dirty Water

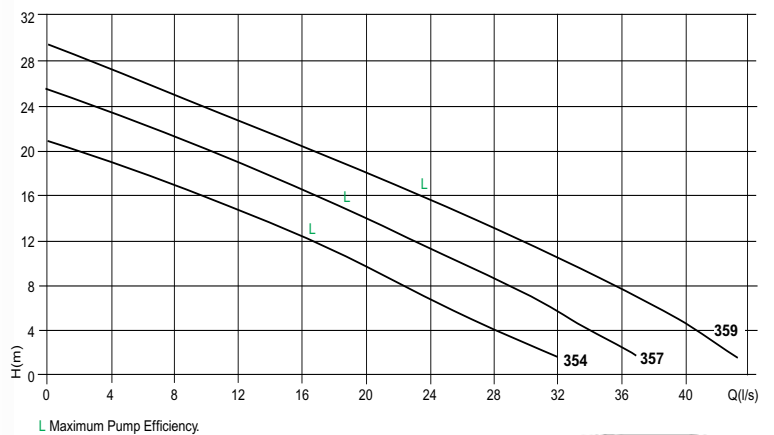
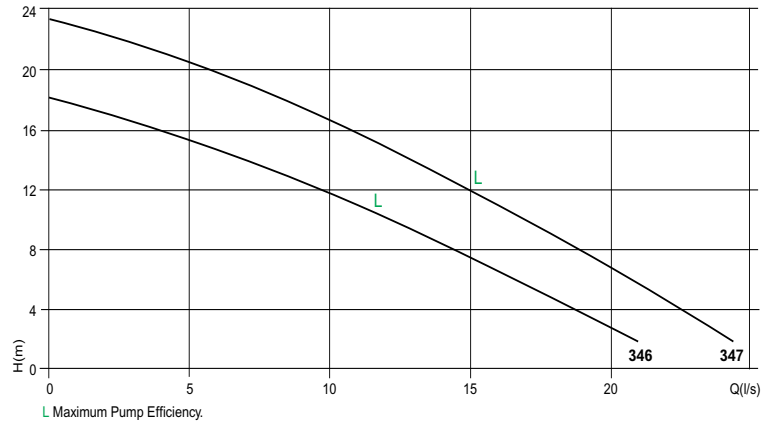

II 2G
Ex db IIB T4 Gb
EX h IIB T4 Gb
0° ≤ Ta ≤ 40°

MODEL	VOLT	OUTLET	LM/HM	Kw	AMP	H x W x L mm	Kg	CODE
VT 80-C.346	400v	DN80	2160/18	3.0	7.3	476 x 244 x 342	60	200-0119
VT 80-C.346 EX	400v	DN80	2160/18	3.0	7.3	476 x 244 x 342	60	200-0119EX
VT 80-C.347	400v	DN80	1470/23	4.0	9.4	476 x 244 x 342	60	200-0117
VT 80-C.347 EX	400v	DN80	1470/23	4.0	9.4	476 x 244 x 342	60	200-0117EX
VT 80-C.354	400v	DN80	1890/21	5.2	10.7	530 x 274 x 362	86	200-0120
VT 80-C.354 EX	400v	DN80	1890/21	5.2	10.7	530 x 274 x 362	86	200-0120EX
VT 80-C.357	400v	DN80	2220/25	7.5	14.5	530 x 274 x 362	91	200-0122
VT 80-C.357 EX	400v	DN80	2220/25	7.5	14.5	530 x 274 x 362	91	200-0122EX
VT 80-C.359	400v	DN80	2640/29	9.2	18.3	530 x 274 x 362	92	200-0139



MODEL	GUIDE RAIL COUPLING, FOOT, CLAW & TOP BRACKET	FREE STANDING BASE P7	THREADED FLANGE DN80 KIT
VTH 80-2/120	✓	✓	✓
VTH 80-2/150	✓	✓	✓
VTH 80-2/200	✓	✓	✓
VTH 80-2/250	✓	✓	✓
CODE	100-11510	100-11628	M62222223

DRENO VTH VORTEX IMPELLER (2 POLE)

E

All main components are made of grey cast iron GG25. Two individual mechanical seals (motor side in the oil chamber, impeller side in contact with the liquid) and high quality parts, ensure the perfect functioning and reliability of the product. The VTH 2 poles Series is used for pumping sewage with suspended solids. High performance renders it useful in a variety of applications including water treatment plants, industrial plants, farming and sewage. Vortex Impellers give ample solids handling. Maximum 40°C liquid temperature. Maximum immersion 20 metres. Complete with 10 metres of power cable.

Features

Cast Iron Pump Body
Cast Iron Impeller
Max Solids 70mm

Applications

Heavy Duty
Sewage
Dirty Water

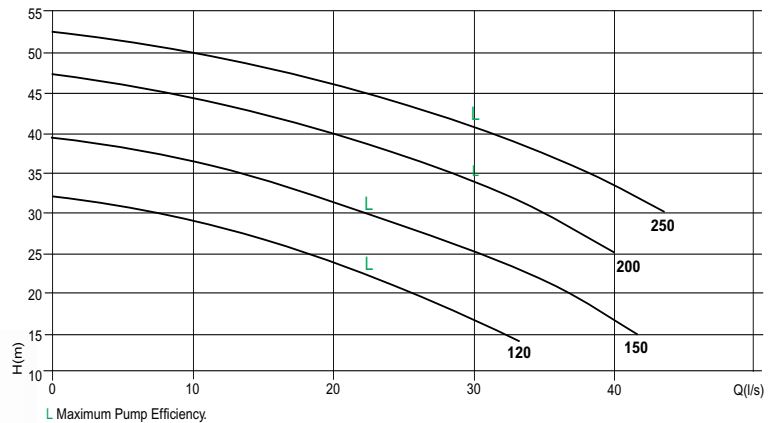

II 2G
Ex db IIB T4 Gb
EX h IIB T4 Gb
0° ≤ Ta ≤ 40°

MODEL	VOLT	OUTLET	LM/HM	Kw	AMP	H x W x L mm	Kg	CODE
VTH 80-2/120	400v	DN80	1950/32	12	22.0	699 x 364 x 507	190	200-0128
VTH 80-2/120 EX	400v	DN80	1950/32	12	22.0	699 x 364 x 507	190	200-0128EX
VTH 80-2/150	400v	DN80	2460/39	15	29.5	699 x 364 x 507	200	200-0130
VTH 80-2/150 EX	400v	DN80	2460/39	15	29.5	699 x 364 x 507	200	200-0130EX
VTH 80-2/200	400v	DN80	2400/44	20	41.0	728 x 364 x 532	242	200-0129
VTH 80-2/200 EX	400v	DN80	2400/44	20	41.0	728 x 364 x 532	242	200-0129EX
VTH 80-2/250	400v	DN80	2580/54	25	47.5	728 x 364 x 532	244	200-0131
VTH 80-2/250 EX	400v	DN80	2580/54	25	47.5	728 x 364 x 532	244	200-0131EX



MODEL	GUIDE RAIL COUPLING, FOOT, CLAW & TOP BRACKET	FREE STANDING BASE P5	THREADED FLANGE DN80 KIT
VM 80-C.341	✓	✓	✓
VM 80-C.342	✓	✓	✓
VT 80-C.344	✓	✓	✓
VT 80-C.345	✓	✓	✓
CODE	100-11510	100-11626	M62222223

DRENO VM/VT VORTEX IMPELLER (4 POLE)

E

All main components are made of grey cast iron GG25. Two individual mechanical seals (motor side in the oil chamber, impeller side in contact with the liquid) and high quality parts, ensure the perfect functioning and reliability of the product. The VT 4 poles Series is used for transport of water with heavy suspended solids. High performance and a wide channel permits its use in industry, including tanneries and farms, and for the movement of water contaminated with soil, or containing large solid pieces. Vortex Impellers give ample solids handling. Maximum 40°C liquid temperature. Maximum immersion 20 metres. Complete with 10 metres of power cable.

Features

Cast Iron Pump Body
 Cast Iron Impeller
 Max Solids 341/342 75mm
 344/345 80mm

Applications

Heavy Duty
 Sewage
 Dirty Water

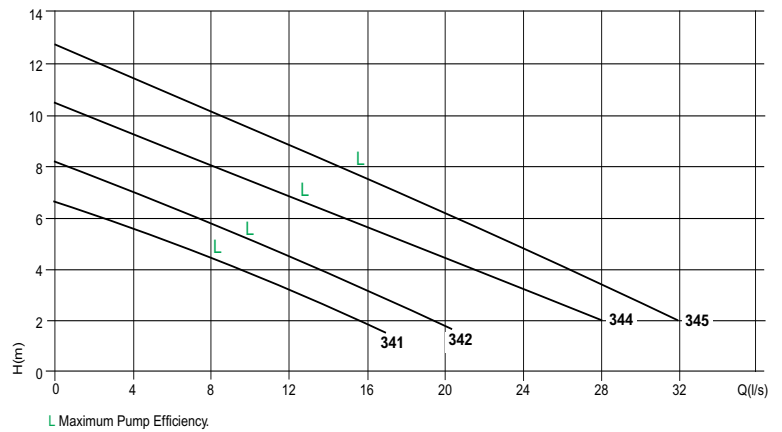

344/345



341/342



II 2G
 Ex db IIB T4 Gb
 EX h IIB T4 Gb
 0° ≤ Ta ≤ 40°

MODEL	VOLT	OUTLET	LM/HM	Kw	AMP	H x W x L mm	Kg	CODE
VM 80-C.341	230v	DN80	1020/6.5	1.1	7.3	453 x 290 x 323	46	200-0142
VM 80-C.341 EX	230v	DN80	1020/6.5	1.1	7.3	453 x 290 x 323	46	200-0142EX
VM 80-C.342	230v	DN80	1230/8	1.25	8.7	453 x 290 x 323	47	200-0146
VM 80-C.342 EX	230v	DN80	1230/8	1.25	8.7	453 x 290 x 323	47	200-0146EX
VT 80-C.341	400v	DN80	1020/6.5	1.1	2.8	453 x 290 x 323	46	200-0140
VT 80-C.341 EX	400v	DN80	1020/6.5	1.1	2.8	453 x 290 x 323	46	200-0140EX
VT 80-C.342	400v	DN80	1230/8	1.25	3.2	453 x 290 x 323	47	200-0144
VT 80-C.342 EX	400v	DN80	1230/8	1.25	3.2	453 x 290 x 323	47	200-0144EX
VT 80-C.344	400v	DN80	1680/10	2.2	5.2	528 x 314 x 385	68	200-0156
VT 80-C.344 EX	400v	DN80	1680/10	2.2	5.2	528 x 314 x 385	68	200-0156EX
VT 80-C.345	400v	DN80	1920/12.5	3.0	7.2	528 x 314 x 385	69	200-0158
VT 80-C.345 EX	400v	DN80	1920.12.5	3.0	7.2	528 x 314 x 385	69	200-0158EX



MODEL	GUIDE RAIL COUPLING, FOOT, CLAW & TOP BRACKET	FREE STANDING BASE P6	THREADED FLANGE DN100 KIT
VT 100-C.348	✓	✓	✓
VT 100-C.349	✓	✓	✓
VT 100-C.350	✓	✓	✓
VT 100-C.355	✓	✓	✓
VT 100-C.356	✓	✓	✓
VT 100-C.358	✓	✓	✓
CODE	100-11511	100-11627	M62222224

DRENO VT VORTEX IMPELLER (4 POLE)

E

All main components are made of grey cast iron GG25. Two individual mechanical seals (motor side in the oil chamber, impeller side in contact with the liquid) and high quality parts, ensure the perfect functioning and reliability of the product. The VT 4 poles Series is used for transport of water with heavy suspended solids. High performance and a wide channel permits its use in industry, including tanneries and farms, and for the movement of water contaminated with soil, or containing large solid pieces. Vortex Impellers give ample solids handling. Maximum 40°C liquid temperature. Maximum immersion 20 metres. Complete with 10 metres of power cable.

Features

Cast Iron Pump Body
 Cast Iron Impeller
 Max Solids 348/349/350 100mm
 355/356/358 90mm

Applications

Heavy Duty
 Sewage
 Dirty Water

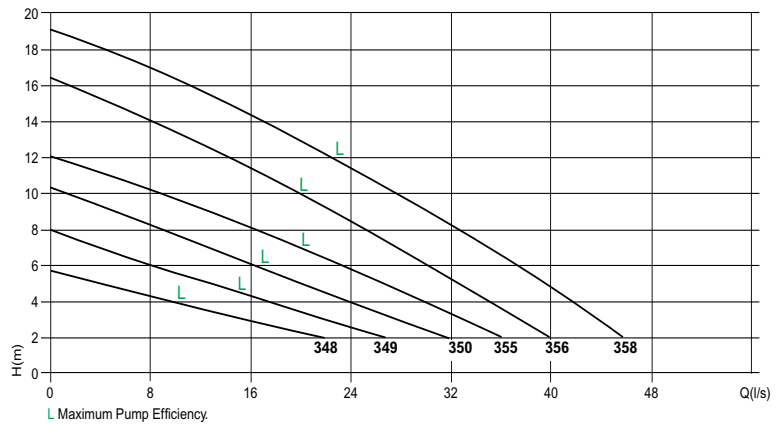

II 2G
 Ex db IIB T4 Gb
 EX h IIB T4 Gb
 0° ≤ Ta ≤ 40°

MODEL	VOLT	OUTLET	LM/HM	Kw	AMP	H x W x L mm	Kg	CODE
VT 100-C.348	400v	DN100	1320/5.5	1.7	3.9	549 x 338 x 405	70	200-0165
VT 100-C.348 EX	400v	DN100	1320/5.5	1.7	3.9	549 x 338 x 405	70	200-0165EX
VT 100-C.349	400v	DN100	1620/8	2.2	5.2	549 x 338 x 405	71	200-0166
VT 100-C.349 EX	400v	DN100	1620/8	2.2	5.2	549 x 338 x 405	71	200-0166EX
VT 100-C.350	400v	DN100	1920/10	3.0	7.2	549 x 338 x 405	74	200-0168
VT 100-C.350 EX	400v	DN100	1920/10	3.0	7.2	549 x 338 x 405	74	200-0168EX
VT 100-C.355	400v	DN100	2160/12	4.0	9.2	609 x 375 x 470	95	200-0174
VT 100-C.355 EX	400v	DN100	2160/12	4.0	9.2	609 x 375 x 470	95	200-0174EX
VT 100-C.356	400v	DN100	2400/16	6.0	12.5	609 x 375 x 470	99	200-0176
VT 100-C.356 EX	400v	DN100	2400/16	6.0	12.5	609 x 375 x 470	99	200-0176EX
VT 100-C.358	400v	DN100	2760/18.5	7.5	15.5	609 x 375 x 470	125	200-0177
VT 100-C.358 EX	400v	DN100	2760/18.5	7.5	15.5	609 x 375 x 470	125	200-0177EX



MODEL	GUIDE RAIL COUPLING, FOOT, CLAW & TOP BRACKET	FREE STANDING BASE P7	THREADED FLANGE DN100 KIT
VT 100-C.362	✓	✓	✓
VT 100-C.363	✓	✓	✓
VT 100-C.370	✓	✓	✓
VT 100-C.375	✓	✓	✓
VT 100-C.380	✓	✓	✓
CODE	100-11511	100-11628	M62222224

DRENO VT VORTEX IMPELLER (4 POLE)

E

All main components are made of grey cast iron GG25. Two individual mechanical seals (motor side in the oil chamber, impeller side in contact with the liquid) and high quality parts, ensure the perfect functioning and reliability of the product. The VT 4 poles Series is used for transport of water with heavy suspended solids. High performance and a wide channel permits its use in industry, including tanneries and farms, and for the movement of water contaminated with soil, or containing large solid pieces. Vortex Impellers give ample solids handling. Maximum 40°C liquid temperature. Maximum immersion 20 metres. Complete with 10 metres of power cable.

Features

Cast Iron Pump Body
Cast Iron Impeller
Max Solids 90mm

Applications

Heavy Duty
Sewage
Dirty Water

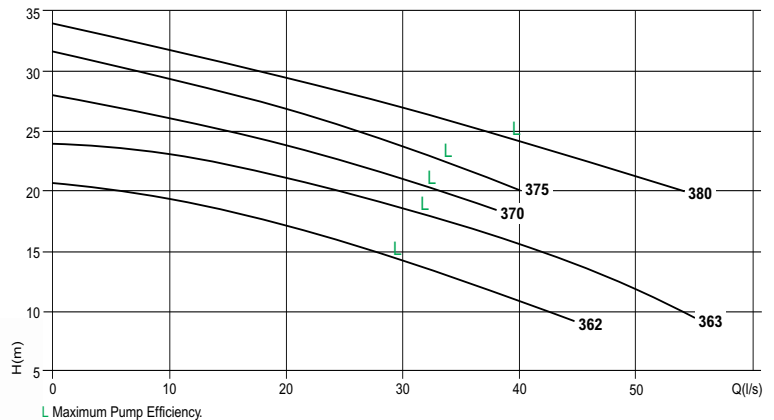

II 2G
Ex db IIB T4 Gb
EX h IIB T4 Gb
0° ≤ Ta ≤ 40°

MODEL	VOLT	OUTLET	LM/HM	Kw	AMP	H x W x L mm	Kg	CODE
VT 100-C.362	400v	DN100	2700/20	12.0	23.8	730 x 385 x 480	192	200-0182
VT 100-C.362 EX	400v	DN100	2700/20	12.0	23.8	730 x 385 x 480	192	200-0182EX
VT 100-C.363	400v	DN100	3300/23	15.0	30.4	730 x 385 x 480	205	200-0184
VT 100-C.363 EX	400v	DN100	3300/23	15.0	30.4	730 x 385 x 480	205	200-0184EX
VT 100-C.370	400v	DN100	2400/28	18.0	36.2	794 x 507 x 504	284	200-1330
VT 100-C.370 EX	400v	DN100	2400/28	18.0	36.2	794 x 507 x 504	284	200-1330EX
VT 100-C.375	400v	DN100	2400/31	20.0	41.0	794 x 507 x 504	290	200-0190
VT 100-C.375 EX	400v	DN100	2400/31	20.0	41.0	794 x 507 x 504	290	200-0190EX
VT 100-C.380	400v	DN100	3240/34	25.0	50.8	794 x 507 x 504	295	200-0192
VT 100-C.380 EX	400v	DN100	3240/34	25.0	50.8	794 x 507 x 504	295	200-0192EX



MODEL	GUIDE RAIL COUPLING, FOOT, CLAW & TOP BRACKET	FREE STANDING BASE P8	THREADED FLANGE DN150
VT 150-C.385	✓	✓	✓
VT 150-C.390	✓	✓	✓
VT 150-C.395	✓	✓	✓
CODE	100-11513	100-11629	100-11578

DRENO VT VORTEX IMPELLER (4 POLE)

E

All main components are made of grey cast iron GG25. Two individual mechanical seals (motor side in the oil chamber, impeller side in contact with the liquid) and high quality parts, ensure the perfect functioning and reliability of the product. The VT 4 poles Series is used for transport of water with heavy suspended solids. High performance and a wide channel permits its use in industry, including tanneries and farms, and for the movement of water contaminated with soil, or containing large solid pieces. Vortex Impellers give ample solids handling. Maximum 40°C liquid temperature. Maximum immersion 20 metres. Complete with 10 metres of power cable.

Features

- Cast Iron Pump Body
- Cast Iron Impeller
- Twin Mechanical Seals
- Max Solids 130mm

Applications

- Heavy Duty
- Sewage
- Dirty Water

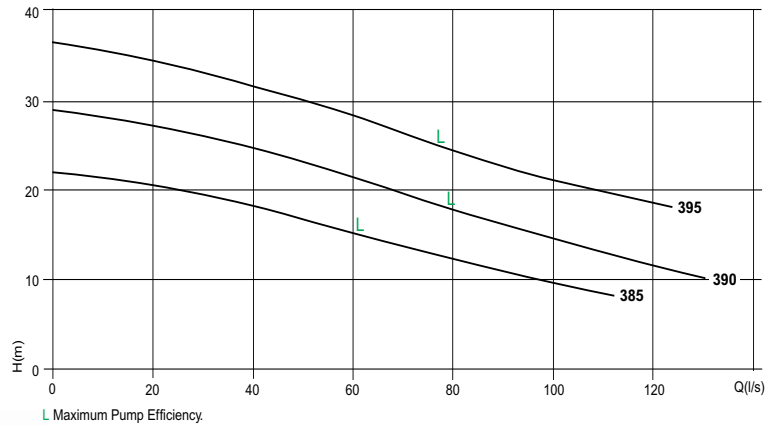

MODEL	VOLT	OUTLET	LM/HM	Kw	AMP	H x W x L mm	Kg	CODE
VT 150-C.385	400v	DN150	6600/22	35.0	68.0	1040 x 605 x 852	550	200-0204
VT 150-C.390	400v	DN150	7800/28	45.0	85.1	1040 x 605 x 852	585	200-0206
VT 150-C.395	400v	DN150	7400/36	55.0	100.5	1040 x 605 x 852	590	200-0208

SUBMERSIBLE PUMPS

DRENO GX GRINDER ACCESSORIES

E



DUTY 50



EASY B

MODEL	EASY B COUPLING FOOT, CLAW & TOP BRACKET	OR	DUTY 50 COUPLING FOOT, CLAW & TOP BRACKET	FREE STANDING BASE P1	FREE STANDING BASE P2	FREE STANDING BASE P3	THREADED FLANGE KIT DN32	THREADED FLANGE KIT DN50
GX 50-2/090	✓		✓				✓	
GX 50-2/110	✓		✓				✓	
GX 50-2/150	✓		✓				✓	
GX 50-2/220	✓		✓				✓	
GM-GT 50-C.155				✓			✓	
GM-GT 50-C.160				✓			✓	
GM-GT 50-C.165					✓			✓
GT 50-C.170					✓			✓
GT 50-C.175						✓		✓
GT 50-C.180						✓		✓
GT 50-C.185						✓		✓
CODE	200-0432		200-0434	100-11622	100-11623	100-11624	M62222220	M62222221

SUBMERSIBLE PUMPS

DRENO GX GRINDER (2 POLE)

E

The main components are fabricated in cast iron GG20. In the standard configuration a lip seal in oil chamber, is fitted to the motor side, and a mechanical seal to the impeller side. The G2 poles Series have an inbuilt macerator in the inlet. This breaks down solids in waste water which permits transport along relatively narrow, often pre-existing, pipes. Applications: domestic sewage, liquids with suspended solids, whenever high pressure (Hm) is needed. The pump has a macerator in the inlet with axial cutting action. The blades are made of hardened steel guaranteeing maximal cutting efficiency. Maximum 40°C liquid temperature. Maximum immersion 20 metres. Complete with 10 metres of power cable.

Features

Cast Iron Pump Body
Cast Iron Impeller
Macerator

Applications

Heavy Duty
Sewage

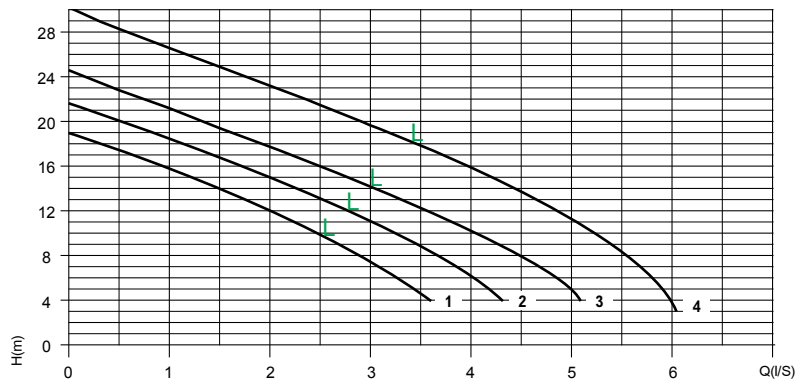

MODEL	VOLT	OUTLET	LM/HM	Kw	AMP	H x W x L mm	Kg	CODE
GX 50-2/090 M	230v	2" / DN32	210/19	0.9	5.5	376 x 180 x 241	25	200-4000
GX EX 50-2/090 M	230v	2" / DN32	210/19	0.9	5.5	376 x 180 x 241	25	200-4000EX
GX 50-2/110 M	230v	2" / DN32	240/21.5	1.1	8.0	376 x 180 x 241	25	200-4006
GX EX 50-2/110 M	230v	2" / DN32	240/21.5	1.1	8.0	376 x 180 x 241	25	200-4006EX
GX 50-2/150 M	230v	2" / DN32	300/24.5	1.5	9.9	398 x 209 x 272	34	200-0043
GX EX 50-2/150 M	230v	2" / DN32	300/24.5	1.5	9.9	398 x 209 x 272	34	200-0043EX
GX 50-2/090 T	400v	2" / DN32	210/19	0.9	2.3	376 x 180 x 241	25	200-4004
GX EX 50-2/090 T	400v	2" / DN32	210/19	0.9	2.3	376 x 180 x 241	25	200-4004EX
GX 50-2/110 T	400v	2" / DN32	240/21.5	1.1	3.1	376 x 180 x 241	25	200-4010
GX EX 50-2/110 T	400v	2" / DN32	240/21.5	1.1	3.1	376 x 180 x 241	25	200-4010EX
GX 50-2/150 T	400v	2" / DN32	300/24.5	1.5	3.6	398 x 209 x 272	34	200-0049
GX EX 50-2/150 T	400v	2" / DN32	300/24.5	1.5	3.6	398 x 209 x 272	34	200-0049EX
GX 50-2/220 T	400v	2" / DN32	360/30	2.2	5.0	398 x 209 x 272	34	200-0051
GX EX 50-2/220 T	400v	2" / DN32	360/30	2.2	5.0	398 x 209 x 272	34	200-0051EX

DRENO GM/GT GRINDER (2 POLE)

E

The main components are fabricated in cast iron GG20. In the standard configuration a lip seal in oil chamber, is fitted to the motor side, and a mechanical seal to the impeller side. The G2 poles Series have an inbuilt macerator in the inlet. This breaks down solids in waste water which permits transport along relatively narrow, often pre-existing, pipes. Applications: domestic sewage, liquids with suspended solids, whenever high pressure (Hm) is needed. The pump has a macerator in the inlet with axial cutting action. The blades are made of hardened steel guaranteeing maximal cutting efficiency. Maximum 40°C liquid temperature. Maximum immersion 20 metres. Complete with 10 metres of power cable.

Features

Cast Iron Pump Body
Cast Iron Impeller
Macerator

Applications

Heavy Duty
Sewage

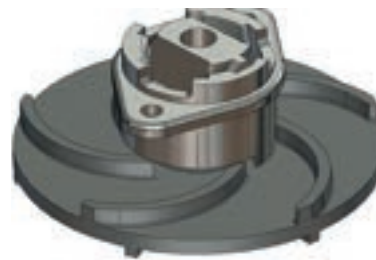
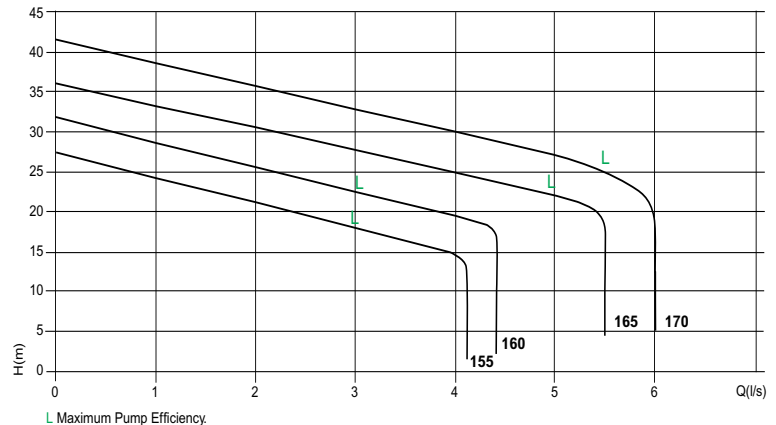

II 2G
Ex db IIB T4 Gb
EX h IIB T4 Gb
0° ≤ Ta ≤ 40°

MODEL	VOLT	OUTLET	LM/HM	Kw	AMP	H x W x L mm	Kg	CODE
GM 50-C.155	230v	2"/DN50	240/26	1.7	11.0	360 x 209 x 286	37.5	200-0048
GM 50-C.155 EX	230v	2"/DN50	240/26	1.7	11.0	360 x 209 x 286	37.5	200-0048EX
GT 50-C.155	400v	2"/DN50	240/26	1.7	4.2	360 x 209 x 286	37.5	200-0052
GT 50-C.155 EX	400v	2"/DN50	240/26	1.7	4.2	360 x 209 x 286	37.5	200-0052EX
GM 50-C.160	230v	2"/DN50	260/30	2.3	13.0	360 x 209 x 286	40	200-0053
GM 50-C.160 EX	230v	2"/DN50	260/30	2.3	13.0	360 x 209 x 286	40	200-0053EX
GT 50-C.160	400v	2"/DN50	260/30	2.3	5.0	360 x 209 x 286	40	200-0054
GT 50-C.160 EX	400v	2"/DN50	260/30	2.3	5.0	360 x 209 x 286	40	200-0054EX
GT 50-C.165	400v	2"/DN50	330/35	3.2	7.0	437 x 253 x 335	61	200-0056
GT 50-C.165 EX	400v	2"/DN50	330/35	3.2	7.0	437 x 253 x 335	61	200-0056EX
GT 50-C.170	400v	2"/DN50	360/41	4.2	9.5	437 x 253 x 365	62	200-0058
GT 50-C.170 EX	400v	2"/DN50	360/41	4.2	9.5	437 x 253 x 365	62	200-0058EX

DRENO GM/GT GRINDER (2 POLE)

E

The main components are fabricated in cast iron GG20. In the standard configuration a lip seal in oil chamber, is fitted to the motor side, and a mechanical seal to the impeller side. The G2 poles Series have an inbuilt macerator in the inlet. This breaks down solids in waste water which permits transport along relatively narrow, often pre-existing, pipes. Applications: domestic sewage, liquids with suspended solids, whenever high pressure (Hm) is needed. The pump has a macerator in the inlet with axial cutting action. The blades are made of hardened steel guaranteeing maximal cutting efficiency. Maximum 40°C liquid temperature. Maximum immersion 20 metres. Complete with 10 metres of power cable.

Features

Cast Iron Pump Body
Cast Iron Impeller
Macerator

Applications

Heavy Duty
Sewage

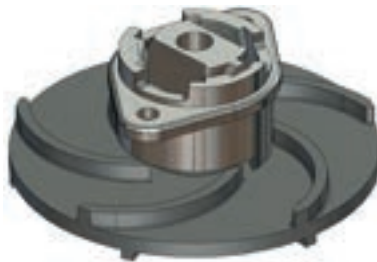
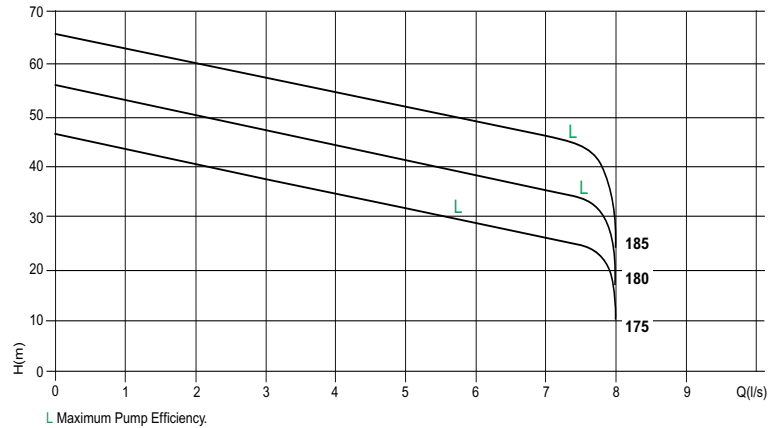

II 2G
Ex db IIB T4 Gb
EX h IIB T4 Gb
0° ≤ Ta ≤ 40°

MODEL	VOLT	OUTLET	LM/HM	Kw	AMP	H x W x L mm	Kg	CODE
GT 50-C.175	400v	2"/DN50	480/46	6.2	12.4	499 x 275 x 383	94	200-0060
GT 50-C.175 EX	400v	2"/DN50	480/46	6.2	12.4	499 x 275 x 383	94	200-0060EX
GT 50-C.180	400v	2"/DN50	480/56	7.8	16.2	499 x 275 x 383	95	200-0062
GT 50-C.180 EX	400v	2"/DN50	480/56	7.8	16.2	499 x 275 x 383	95	200-0062EX
GT 50-C.185	400v	2"/DN50	480/66	9.5	20.0	499 x 275 x 383	96	200-0065
GT 50-C.185 EX	400v	2"/DN50	480/66	9.5	20.0	499 x 275 x 383	96	200-0065EX

CONTROL EQUIPMENT

BASIC PUMP CONTROL PANELS

E

Simplex control panels for one pump control of sump pumps, booster pumps or borehole pump. Operation by floats, pressure switches or level probes. Duplex control panels for two pump control of sump pumps or booster pumps. Operation by floats or pressure switches. Both have provision for klaxon connections and a 12 Volt DC Alarm control circuit. Plastic ABS boxes and IP55 Rated.

Features

Single Pump Control
Twin Pump Control
Optional Alarm Features

Applications

Pump Stations
Booster Sets
Wells & Boreholes



FLASHING BEACON



PANEL SOUNDER

MODEL	VOLT	Kw RANGE	AMP RANGE	SINGLE OR TWIN PUMP	OPERATION*	H x W x L mm	Kg	CODE
SIMPLEX-UP M/3	230v	0.37-2.2	2-16	SINGLE	PR/FL/PS	340 x 240 x 170	1.9	021-005
SIMPLEX-UP M/3 110	110v	0.37-2.2	2-16	SINGLE	PR/FL/PS	340 x 240 x 170	1.9	021-007
SIMPLEX-UP T/10	400v	0.55-7.5	2-15	SINGLE	PR/FL/PS	340 x 240 x 170	2.4	021-010
SIMPLEX-UP T/15	400v	7.5-11	16-24	SINGLE	PR/FL/PS	340 x 240 x 170	2.6	021-015
DUPLEX-UP M/3	230v	0.37-2.2	2-16	TWIN	FL/PS	340 x 240 x 170	2.0	021-025
DUPLEX-UP T/10	400v	0.55-7.5	2-16	TWIN	FL/PS	340 x 240 x 170	2.8	021-030

*PR – PROBES / FL – FLOATS / PS – PRESSURE SWITCH

ACCESSORIES

D

OPTIONAL EXTRA'S – HIGH LEVEL ALARM EQUIPMENT

CODE

12 VOLT AC/DC 22mm PANEL SOUNDER / CONTINUOUS LIT LAMP IP20

200-002

FLASHING BEACON 12/24 VOLT DC

309-5922

CONTROL EQUIPMENT

CONTROL PUMP PLUS

E

New all in one multi voltage control pump plus panel. 230v input supply to control a single pump or twin pumps. 400v input supply to control a single pump or twin pumps. On twin pump set up there are alternate and assist functions. Run and trip indicators, auto/off/manual button. In built alarm buzzer. For sump pumps, surface booster pumps and well pumps – almost all applications. Easy to follow set up and wiring diagram. Anti rotor lock function (drainage set up only). Plastic ABS box IP55 rated.

Features

- 230v or 400v Supply
- Single or Twin Pump
- NO & NC Alarm Contact
- Operations by Floats/Probes or Pressure Switches

Applications

- Pump Sewage Stations
- Booster Sets
- Wells & Boreholes

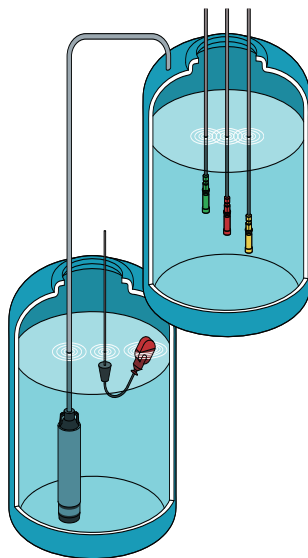
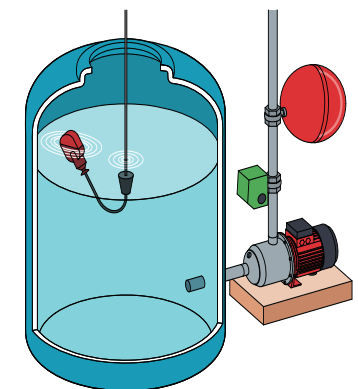
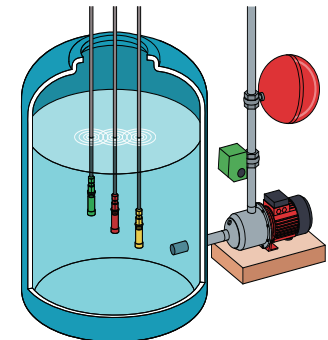
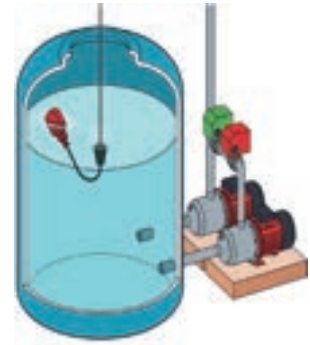

MODEL	VOLT	Kw RANGE	AMP RANGE	SINGLE OR TWIN	OPERATION	H x W x L mm	CODE
CONTROL PUMP PLUS	230v & 400v	UP TO 1.5Kw UP TO 5.5kw	0.25-15	SINGLE & TWIN	FLOATS/ PROBES/ PRESSURE SWITCHES	305 X 224 x 127	021-400

CONTROL EQUIPMENT

STAR DELTA PUMP CONTROL PANELS

D

IP54 Steel enclosure with interlock main Isolator. Line fuses and overload relays. Transformer for low voltage circuit, auto changeover relay (twin pump) run and trip indicators and hour counter, auto off manual switch. Alarm circuit 24v AC. Single pump panels require a two float operation (three if using the alarm feature). Twin pump panels require a three float operation (four if using the alarm feature).

Features

Star Delta
Single Or Twin Pump Control
Optional Alarm Features

Applications

Pump Stations



EXAMPLE – STAR DELTA TWIN CONTROL PANEL



PANEL SOUNDER



FLASHING BEACON



FLASHING BEACON
SOUNDER

MODEL	VOLT	Kw RANGE	AMP RANGE	SINGLE OR TWIN PUMP	OPERATION	H x W x L mm	Kg	CODE
DELTA1/10	400v	7.5	9-12.5	SINGLE	FLOATS	420 x 320 x 170	6.0	021-132
DELTA1/15	400v	11	11-16	SINGLE	FLOATS	420 x 320 x 170	6.0	021-134
DELTA1/20	400v	15	14-20	SINGLE	FLOATS	530 x 400 x 230	16.0	021-136
DELTA2/10	400v	7.5	9-12.5	TWIN	FLOATS	630 x 400 x 230	12.0	021-138
DELTA2/15	400v	11	11-16	TWIN	FLOATS	630 x 400 x 230	12.0	021-140
DELTA2/20	400v	15	14-20	TWIN	FLOATS	690 x 500 x 230	32.0	021-145
OPTIONAL EXTRA'S – HIGH LEVEL ALARM EQUIPMENT								CODE
RECTIFIER AC-DC & INTERNAL BUZZER / REMOTE CONNECTION								200-001
24 VOLT AC/DC 22mm PANEL SOUNDER / CONTINUOUS LIT LAMP IP20								200-003
FLASHING BEACON 12/24 VOLT DC								309-5922
FLASHING BEACON / SOUNDER 24 VOLT DC								530-6016

CONTROL EQUIPMENT

FULL CONTROL PANELS

C

IP55 Steel enclosure with interlock main isolator. Line fuses and overload relays. Transformer for low voltage circuit, auto changeover (twin pump) run and trip indicators and hour counter, auto/off manual switch. Alarm circuit 24v DC. Alarm panel sounder / lit lamp installed. Single pumps require a two float operation (three if using the alarm feature) Twin pump panels require a three float operation (four if using the alarm feature).

Features

Single Or Twin Pump Control
Mechanical Operation

Applications

Pump Stations



EXAMPLE SINGLE PUMP PANEL

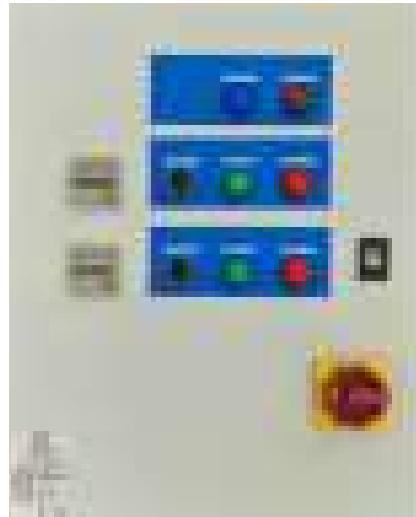

EXAMPLE TWIN PUMP PANEL



FLASHING BEACON



FLASHING BEACON
SOUNDER

MODEL	VOLT	Kw RANGE	AMP RANGE	SINGLE OR TWIN PUMP	OPERATION	H x W x L mm	Kg	CODE
DIRECT 1 MOTOR SEWAGE	230v	0.1-1.1	1-8	SINGLE	FLOATS	500 x 400 x 210	10	020-722 (8A)
DIRECT 1 MOTOR SEWAGE	230v	1.1-2.2	6-16	SINGLE	FLOATS	500 x 400 x 210	10	020-722(16A)
DIRECT 2 MOTOR SEWAGE	230v	0.1-1.1	1-8	TWIN	FLOATS	500 x 400 x 210	10	020-724 (8A)
DIRECT 2 MOTOR SEWAGE	230v	1.1-2.2	6-16	TWIN	FLOATS	500 x 400 x 210	17	020-724 (16A)
DIRECT 1 MOTOR SEWAGE	400v	0.1-2.2	1-8	SINGLE	FLOATS	500 x 400 x 210	10	020-726 (8A)
DIRECT 1 MOTOR SEWAGE	400v	2.2-7.5	6-16	SINGLE	FLOATS	500 x 400 x 210	10	020-726 (16A)
DIRECT 2 MOTOR SEWAGE	400v	0.1-2.2	1.8	TWIN	FLOATS	500 x 400 x 210	17	020-728 (8A)
DIRECT 2 MOTOR SEWAGE	400v	2.2-7.5	6-16	TWIN	FLOATS	500 x 400 x 210	17	020-728 (16A)
OPTIONAL EXTRA'S – HIGH LEVEL ALARM EQUIPMENT								CODE
FLASHING BEACON 12/24 VOLT DC								309-5922
FLASHING BEACON / SOUNDER 24 VOLT DC								530-6016

CONTROL EQUIPMENT

FULLAPP3- 3 PUMP CONTROL PANELS

D

Fullapp 3 control panels for 3 pump operation, Main switch with door interlock, AUTO-0-MAN buttons, LED power on, auto operation. Selector for filling/emptying operation, internal regulator for probes sensitivity, adjustable motor overload protection. Provision for start-up capacitors on 230v model. Optical/acoustic alarm output 12V 100mA. 230v model comes in a plastic ABS enclosure, 400v model comes in a metal enclosure, both IP55 rated.

Features

- Control 3 Pumps
- Alternating, Assist, Assist
- Optional Alarm Features

Applications

- Pump Stations
- Booster Sets



EXAMPLE TRIPLE PUMP PANEL 230v



EXAMPLE TRIPLE PUMP PANEL 400V



PANEL SOUNDER



FLASHING BEACON

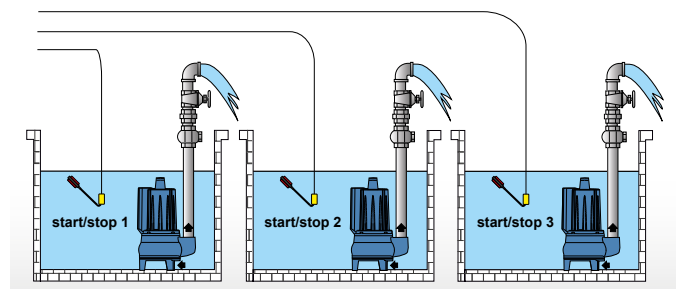
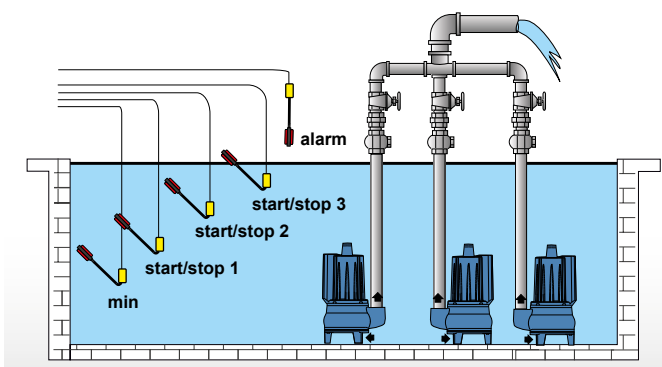

INSTALLATION EXAMPLES

MODEL	VOLT	Kw RANGE	AMP RANGE	OPERATION*	H x W x L mm	Kg	CODE
FULL APP	230v	0.37-2.2	2-18	PR/FL/PS	400 x 300 x 200	6.0	021-120
FULL APP	400v	0.55-7.5	2-15	PR/FL/PS	500 x 400 x 200	10.0	021-125

*PR - PROBES / FL - FLOATS / PS - PRESSURE SWITCH

CONTROL EQUIPMENT

HIGH/LOW LEVEL ALARM PANELS

E

High or low level alarms can be used for almost any application where detection of high or low level liquids needs to be raised. Low voltage output for float connection (Float not included). Complete with acoustic and visual alarm. Beeper & Top Alarm have NO and NC contacts for remote signalling. Beeper SQ 9v is a basic stand alone unit, powered by an internal 9 volt battery only (included, but not recharge type). Top Alarm has battery back up, optional power failure alarm, optional alarm delay timer.

Features

High Or Low Level Alarm
Acoustic Alarm
Visual Alarm*
NO NC Output Contacts*
*Refer To Model

Applications

Pump Stations
Booster Sets
Wells & Boreholes
Tanks



BEEPER



TOP ALARM

MODEL	VOLT	OPERATION	H x W x L mm	Kg	CODE
BEEPER SQ 2	230/400v	FLOAT	270 x 120 x 95	1	020-013
BEEPER SQ 9	9v DC	FLOAT	270 x 120 x 95	1	020-014
TOP ALARM	230v	FLOAT	180 x 140 x 140	1.5	021-204

ACCESSORIES

PUMP LIFTING CHAIN & KIOSK

C

Pump pit chain made from 6mm stainless steel 316. 10 metre length with index lifting points at each end and at 1 metre centres. Maximum load 400 kilos. Pump pit shackles are also made from 6mm stainless steel 316.

Single door Metal kiosks are used to protect control panels and electrical equipment from the weather elements. Triangular lock. Dimensions are approximate.



MODEL	Kg	CODE
PUMP PIT CHAIN 10m	9.6	100-10000
PUMP PIT SHACKLE	0.16	100-10001

MODEL	OUTER DIM mm	INTERNAL DIM mm	Kg	CODE
KIOSK	1000H x 700W x 450L	970H x 680W x 380L	40.0	020-700
	DOOR SIZE DIM mm	BACKING BOARD DIM mm		
	890H x 540W	800H x 680W		

CONTROL EQUIPMENT

SINGLE & DOUBLE ACTION FLOAT SWITCHES

E

Microstart/I and Minimatic/C floats are built to withstand humidity and condensation (patented). Water resistant to 100 metres depth. Level control for filling and emptying tanks or cisterns. Single outer casing piece in blow moulded polyethylene. Inner chamber built as a single blowmoulded piece for the switch and ball seat. Non-hygroscopic closed cells injection of expanded polyurethane in the regulator to eliminate air and to hermetically seal the unit. Max working pressure 10 bar. Microstart/I floats are single action floats. Minimatic/C floats are double action floats.

Features

Single Action Floats
Double Action Floats
Maximum Temp 45°C

Applications

Pump Stations
Tanks
Wells



MICROSTART/I



MINIMATIC/C



COUNTER WEIGHT

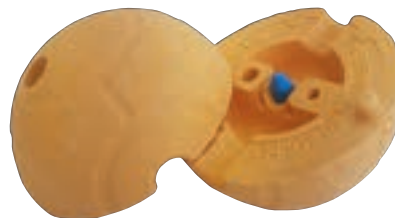

SHELL COUNTER WEIGHT

MODEL	LENGTH (METRE)	CABLE TYPE	OPERATION	Kg	CODE
MICROSTART/I 0.5	0.5	PVC	SINGLE ACTION	0.5	030-549
MICROSTART/I 5	5	PVC	SINGLE ACTION	0.7	030-550
MICROSTART/I 10	10	PVC	SINGLE ACTION	1.1	030-552
MICROSTART/I 15	15	PVC	SINGLE ACTION	1.5	030-554
MICROSTART/I 20	20	PVC	SINGLE ACTION	1.9	030-556
MICROSTART/I 30	30	PVC	SINGLE ACTION	2	030-558
MINIMATIC/C 5M	5	PVC	DOUBLE ACTION	0.7	030-562
MINIMATIC/C 10M	10	PVC	DOUBLE ACTION	1.1	030-564
MINIMATIC/C 15M	15	PVC	DOUBLE ACTION	1.5	030-566
MINIMATIC/C 20M	20	PVC	DOUBLE ACTION	1.9	030-568
MINIMATIC/C 30M	30	PVC	DOUBLE ACTION	3	030-570
COUNTER WEIGHT				0.13	030-580
SHELL COUNTER WEIGHT				0.23	9000-0025

Heavyweight floats for sewage and waste water with double action floats for emptying or filling operation. 3 core connections. Operation at 5 degrees and tilt from centre for ease of operation. Sewage MC floats come complete with counterweight. Little Mercury MC floats same design as the MC but smaller in size for more compact tanks and vessels and complete with counter weight. ECO LM are a new design of sewage float with built in internal weight close to the cable connection.

Features

Double Action Floats
Maximum Temp 45°C
Heavy Weight

Applications

Pump Stations
Tanks



MC



LITTLE MC



ECO LM



COUNTER WEIGHT

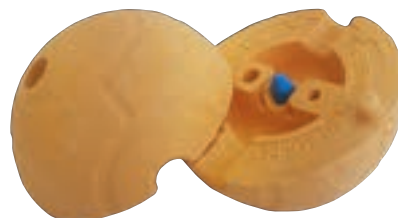

SHELL COUNTER WEIGHT

MODEL	LENGTH (METRE)	CABLE TYPE	OPERATION	Kg	CODE
MC6	6	PVC	DOUBLE ACTION	1.3	030-620
MC13	13	PVC	DOUBLE ACTION	1.9	030-622
MC20	20	PVC	DOUBLE ACTION	2.3	030-624
MC30	30	PVC	DOUBLE ACTION	3.5	030-626
MC50	50	PVC	DOUBLE ACTION	6.0	030-629
LITTLE MC10	10	PVC RUBBER	DOUBLE ACTION	1.3	030-632
LITTLE MC20	20	PVC RUBBER	DOUBLE ACTION	2.1	030-634
ECO LM 10	10	PVC RUBBER	DOUBLE ACTION	1.2	030-674
ECO LM 20	20	PVC RUBBER	DOUBLE ACTION	2.0	030-676
COUNTER WEIGHT				0.13	030-580
SHELL COUNTER WEIGHT				0.23	9000-0025

CONTROL EQUIPMENT

SPECIAL APPLICATION FLOAT SWITCHES

E

Minimatic WRAS approved float switch for level control filling or emptying tanks or cisterns. WRAS approved counterweight also available if required. Little EX for use in the regulation of diesel oil, water and hydrocarbon mixture, motor oils, tools, machine oils, etc. Matic V/MC Float switch insensitive to humidity and condensation realised to control directly the liquid or water – vapour level up to a max. temperature of 130°C and max. pressure of 4 bar. Due to the possible temperature at which the regulator could be used, the outer casing is made in 304 AISI stainless steel and the electric cable sheath is resistant to high temperatures.

Features

Single Action Floats
Double Action Floats

Applications

Pump Stations
Tanks
Wells



LITTLE EX ATEX



MINIMATIC/C WRAS



MATIC/V/MC
HOT WATER



WRAS COUNTER WEIGHT

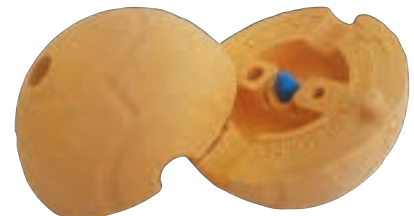

SHELL COUNTER WEIGHT

MODEL	LENGTH (METRE)	CABLE TYPE	OPERATION	Kg	CODE
MINIMATIC/C (WRAS) 5	5	EPDM	DOUBLE ACTION	0.8	030-650
MINIMATIC/C (WRAS) 10	10	EPDM	DOUBLE ACTION	1.5	030-652
MINIMATIC/C (WRAS) 15	15	EPDM	DOUBLE ACTION	2.2	030-654
MINIMATIC/C (WRAS) 20	20	EPDM	DOUBLE ACTION	2.9	030-656
MINIMATIC/C (WRAS) 30	30	EPDM	DOUBLE ACTION	4.3	030-658
COUNTER WEIGHT (WRAS)				0.15	030-582
LITTLE EX (ATEX) 5	5	POLYURETHANE	DOUBLE ACTION	0.6	030-638
LITTLE EX (ATEX) 10	10	POLYURETHANE	DOUBLE ACTION	0.9	030-640
LITTLE EX (ATEX) 20	20	POLYURETHANE	DOUBLE ACTION	1.4	030-642
MATIC/V/MC 6	6	SILICON	SINGLE ACTION	0.6	030-590
MATIC/V/MC 10	10	SILICON	SINGLE ACTION	1	030-592
MATIC/V/MC 20	20	SILICON	SINGLE ACTION	1.90	030-594
COUNTER WEIGHT (WRAS)				0.13	030-582
SHELL COUNTER WEIGHT				0.23	9000-0025

CONTROL EQUIPMENT

SPECIAL APPLICATION FLOAT SWITCHES – RETRO FIT

E

MAC3 is one of the most widely used float switches retrofitted to submersible pumps. High quality with double liquid proof chamber for maximum reliability. Agma for use in tight spaces where a normal float switch could not operate. Reka2000 level regulator is a device that controls equipment once it has reached a pre-established level. A capacity sensor is integrated in the plastic structure and this makes it suitable for a wide range of liquids. (Note – Oils, fats and grease are not recommended as they act as an insulator.) It can be operated by mains electricity and due to an internal relay, it is able to control pumps up to 0.75kw/1 HP and is easy to install near the pump itself or can be fitted directly onto JS single phase pumps as an integral unit. New to the range is the mouse. Similar to the Agma, this has two floating bodies that can be moved along the shaft to regulate the minimum and maximum level. Can be used in auto and manual mode.

Features

Single Action Floats
Double Action Floats

Applications

Pump Stations
Tanks
Wells



**REKA 2000 230v
C/W 10M CABLE**



MAC 3



**REKA 2000 110v
C/W 10M CABLE**



AGMA



**MOUSE WITH CABTYRE
GLAND FIXING**



**REKA C/W CABTYRE GLAND
SHOWN FITTED ONTO JS250**



**REKA C/W CABTYRE GLAND
SHOWN ONTO JS150SV**



REKA BRACKET

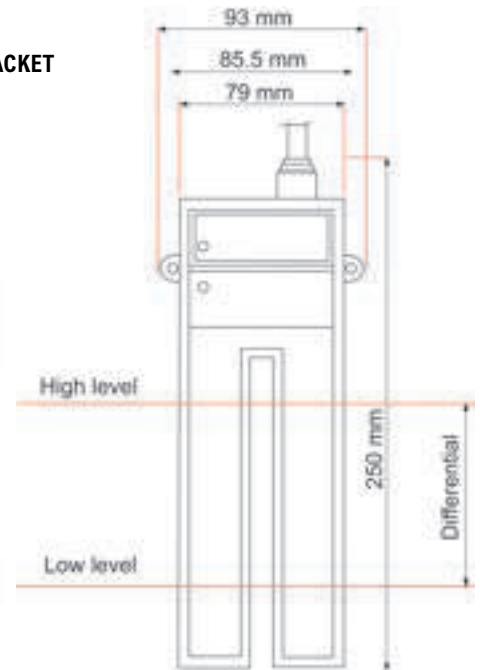

MODEL	LENGTH (METRE)	CABLE TYPE	OPERATION	Kg	CODE
MAC-3 FLOAT & GLAND	0.5	H07RNF	SINGLE ACTION	0.5	020-001
AGMA c/w 10M CABLE	10	H07RNF	SINGLE ACTION	1.2	020-003
REKA 2000* 110v	0.4	H07RNF	SINGLE ACTION	0.5	020-004-110
REKA 2000 110v	10	H07RNF	SINGLE ACTION	3.0	020-004-110-10
REKA 2000* 230v	0.4	H07RNF	SINGLE ACTION	2.0	020-004-230
REKA 2000 230v	10	H07RNF	SINGLE ACTION	3.0	020-004-230-10
REKA 2000 12/24v DC	10	H07RNF	SINGLE ACTION	3.5	020-004-DC
BRACKET	/	/	/	0.5	020-004-KT
MOUSE	10	H07RNF	SINGLE ACTION	1.2	020-002

*Complete with Cabtyre type cable gland on the end of the 0.4m cable. It is advisable to let us fit the Reka to the chosen model.

CONTROL EQUIPMENT

SPECIAL APPLICATION LEVEL CONTROL

E

Submatic electronic control units to be used with two probe “N”s allowing emptying or filling without the need for float switches. Levels are dependent on the difference in the position of the probes. **Probe N**, Twin probes, available in various cable lengths. **ST-70AB** for wall or tank mounting. Twin liquid filled balls working on displacement. Contacts can be used for filling or emptying differential 20mm to 1 metre. **Divermatic** is a portable signalling device, visual and acoustic, for the measuring of the water level in a borehole. Divermatic is complete with metric cable, numbered by a 0-200 metre scale and a cable reel. Power supply is by a 9 volt battery which is included in the device. With the marked metric numerical cable sheath it is possible to read the depth to the water surface by means of a probe which provides a lit LED and acoustic signal. **Level probes x 3**, bare probes no cable. Non toxic material, suitable for clean water.

Features

Single Action Floats
 Double Action Floats
 Maximum Temp 45°C

Applications

Pump Stations
 Tanks/Wells



SUBMATIC Q



PROBE N



LEVEL PROBES x 3 (BARE)



DIVERMATIC



ST-70AB

MODEL	LENGTH (METRE)	CABLE TYPE	OPERATION	Kg	CODE
SUBMATIC Q 230v/400v	/	/	/	1	030-535
SUBMATIC Q 110v	/	/	/	1	030-538
PROBE N 10	10	PVC	SINGLE ACTION	0.8	030-546
PROBE N 20	20	PVC	SINGLE ACTION	1.6	030-548
PROBE N 30	30	PVC	SINGLE ACTION	2.4	030-544
PROBE N 50	50	PVC	SINGLE ACTION	4.0	030-628
PROBE N 100	100	PVC	SINGLE ACTION	8.0	030-630
LEVEL PROBES x 3	/	/	/	0.50	9000-0030
ST-70AB	/	/	DOUBLE ACTION	0.6	030-500
DIVERMATIC	200	PVC	/	9.4	030-660

CONTROL EQUIPMENT

UTILITY LOW LEVEL CONTROL

E

Utility 15 panels and utility sensor can control low levels of water when using a residue puddle sucker pump. Can be used with the RSD, PXL and Puddle Buddy. The sensor can work horizontally on the floor or in a vertical position fixed to a wall or to a pipe into small pits and narrow spaces. The sensor has 3 level points and combined to the Utility 15 control panel can be used for checking water or controlling a pump and signalling a too high level point if required.

Features

Low level control
Control Residue Pumps

Applications

Pump Stations
Tanks
Lift Shafts
Basements



UTILITY 15 PANEL



PUDDLE SENSOR

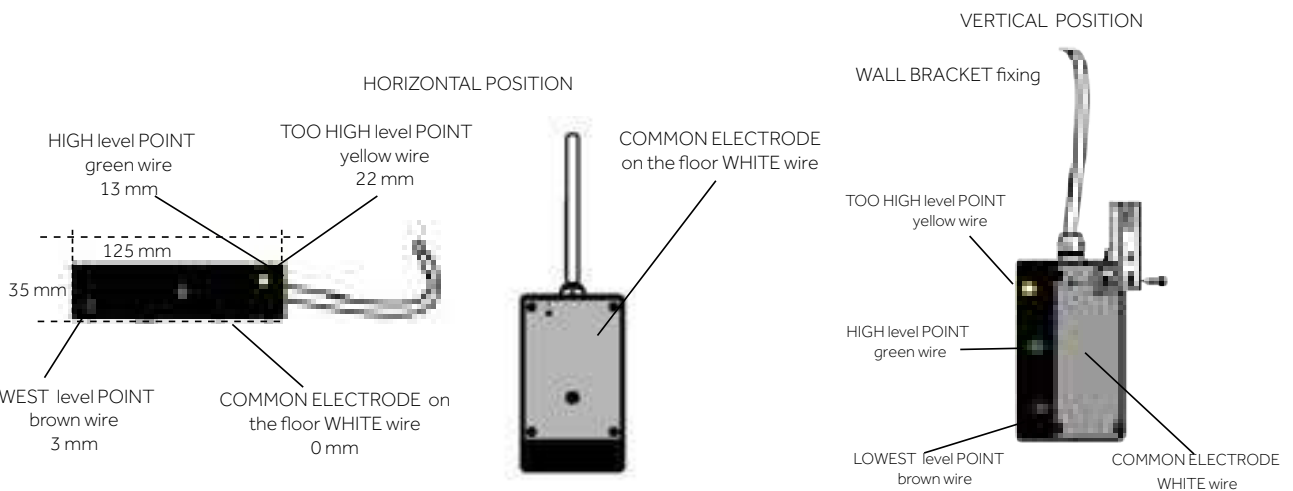

MODEL	VOLT	Kw RANGE	AMP RANGE	OPERATION	H x W x L mm	Kg	CODE
UTILITY 15	110/230v	0.15-0.4	1-8	PROBES	210 x 210 x 100	1.2	030-600
PUDDLE SENSOR	/	/	/	/	35 x 125 x 70	0.85	030-602

CONTROL EQUIPMENT

THE CRAB – LOW LEVEL PROBE SENSOR

E

Resting on a flat surface, it remains weighted to the bottom, allowing to detect the presence of water from the floor. By means of the magnetic key supplied, the customer is able to adjust the delay time of start and stop according to the own needs of use. The Crab can be connected directly to a pump without the need of a traditional control panel. Suitable for level monitoring in clear and dirty waters. Adjustable start and stop delay time. Cable length 30cm. Designed to be fitted onto our range of JS RSD400, JS RSD150 and the Ponstar PXL puddle pumps. The factory setting is as follows - Pump turns on 5 seconds after the 2 sensors detect the water at 3mm level. Pump then turns off 30 seconds after the 2 sensors do not detect the water anymore. Now available for 110v pumps up to 6 amps.

Features

Low Level Control
Control Residue Pumps

Applications

Tanks
Lift Shafts
Basements



THE CRAB SHOWN FITTED TO THE RSD150 RESIDUE PUMP



THE CRAB

MODEL	VOLTAGE	CONNECTION	MAX AMPS	H x W x L mm	Kg	CODE
CRAB	230v	CABTYRE	5	100 x 50 x 116	0.28	020-010
CRAB	110v	CABTYRE	6	100 x 50 x 116	0.28	020-012

Small pumping stations for the collection and lifting of water from the bath, sink, shower and washing machines in basements or below the sewer line. Novabox consists of a Nova 300 pump in a 30 litre tank, standard level arm float fitted as standard but also supplied is the low level shower float kit. Nova box requires assembly. JS Box 150 has the JS150SV pump fitted and the JS Box 250 has the JS250SV fitted. Both pumps are fitted with the Agma W float switch which can be adjusted for different level turn on & off's if required from the factory setting. All require assembly.

Features

Automatic Pump Units

Applications

Under Sink
Utility Room

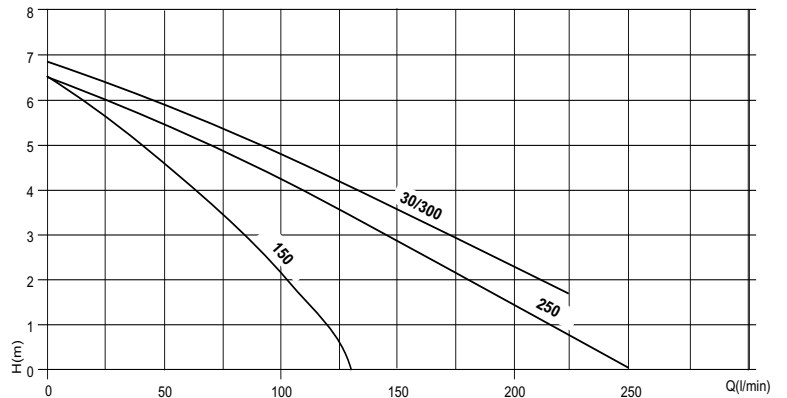

MODEL	VOLT	OUTLET	LM/HM	Kw	Amp	H x W x L mm	Kg	CODE
NOVABOX 30/300 1M	230v	1¼"	220/6.9	0.22	1.3	360 x 311 x 409	9.2	020-771
JS BOX 150	230v	1¼"	125/6.5	0.15	1.4	352 x 300 x 400	10	9000-4060
JS BOX 250	230v	1½"	240/6.5	0.25	1.9	452 x 400 x 600	16	9000-4065

Complete wastewater pumping unit for installation at floor level and fitted with a submersible pump from the Robusta or MF ranges. Suitable for the removal of liquids containing solid adjustable from 10mm up to 30mm depending on model, from wash-hand basins, domestic washing machines, or showers, from areas below the sewer level. Compact triangular design optimises space beneath a hand-wash basin. Can be fitted with Robusta 202 TS or MF 154 & 324 pumps, complete with non-return valve and level control. A separate check valve should be used at heads over 5m. Seven ports (5 x 40mm, 2 x 50mm), ready-prepared with seals, which can be used for inflow, discharge, power cable, or flexible hose connection to a washing machine (3/4" adaptor supplied).

Features

- Automatic Pump Units
- Max Solids
- Robusta 202 10mm
- MF 154W 20mm
- MF324W 30mm

Applications

- Under Sink
- Utility Room

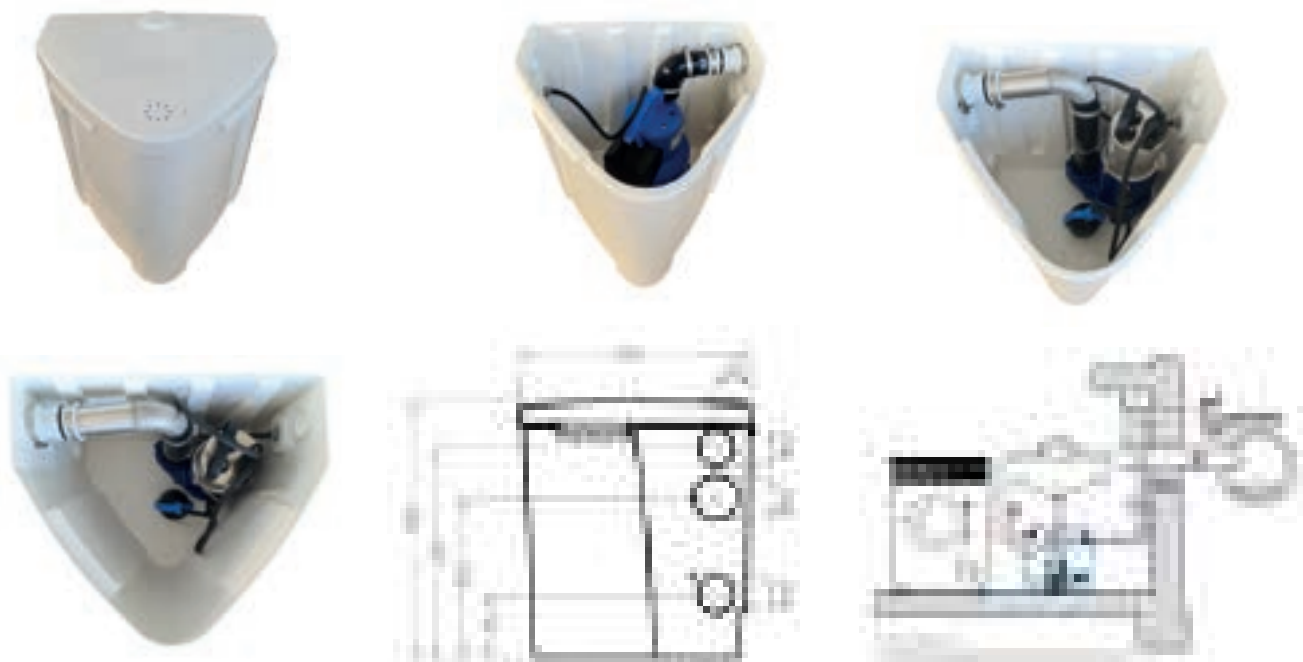
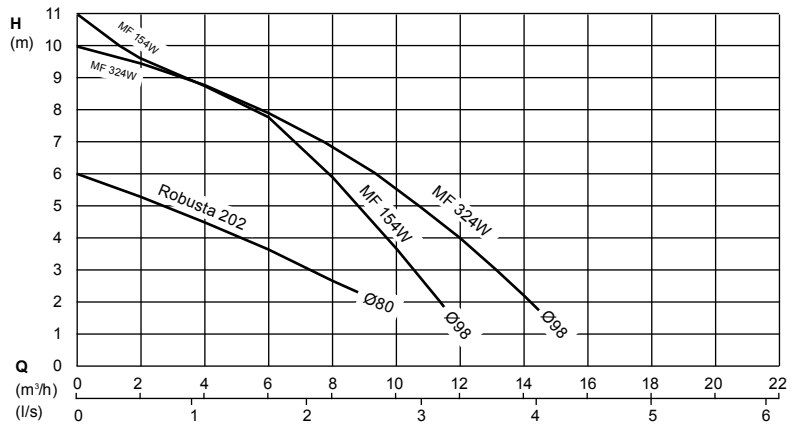

MODEL	VOLT	OUTLET	LM/HM	Kw	AMP	H x W x L mm	Kg	CODE
SANIMAX R202	230v	40mm	150/6	0.36	1.6	390 x 345 x 400	6.75	020-783
SANIMAX MF154HW	230v	40mm	200/11	0.65	2.83	390 x 345 x 400	13.5	020-796
SANIMAX MF324HW	230v	40mm	300/9.5	0.83	3.61	390 x 345 x 400	13.5	020-798

SURFACE MOUNTED PUMPS

PENTAX



Page 154



Page 155



Page 156



Page 35 & 35



Page 20



Page 34 & 35



Page 142

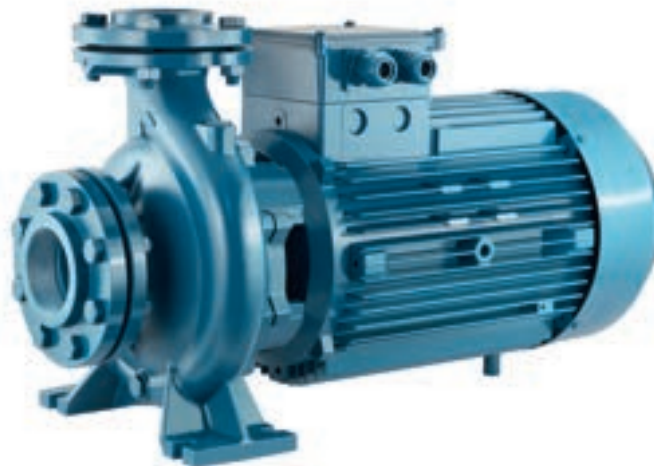

Page 174 - 181



Page 143



Page 142



Page 143



GENIX is indispensable when the wastewater coming from WCs, showers, washbasins, or bidet cannot be expelled by gravity. These lifting stations can be installed wherever there is the wish to add a toilet during new installations, renovations or new constructions. In the model 110, beside the WC, an additional line can be connected such as a wash basin. In the model 130, besides the WC, three more lines can be connected such as a shower, washbasin and bidet. Comfort versions offer even better silent running. Extremely easy maintenance in case of clog or motor blocking.

Features

Automatic Pump Units

Applications

WC Waste
Wash Basin

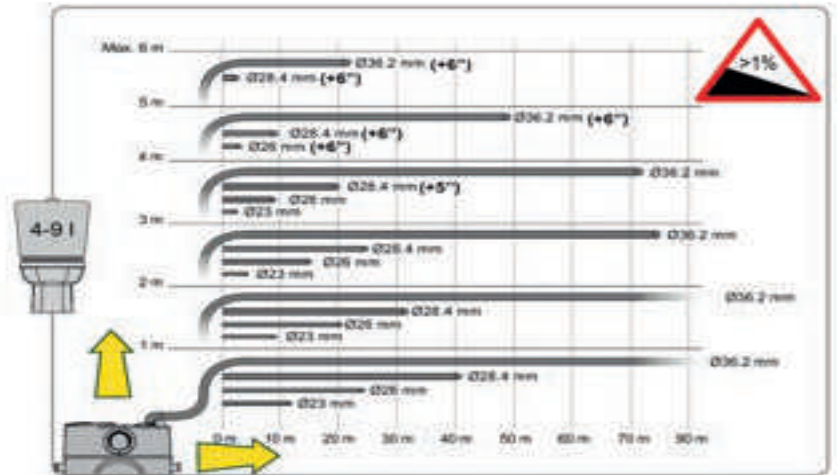

MODEL	VOLTAGE	INLET / OUTLET	LM/HM	Kw	AMPS	H x W x L mm	Kg	CODE
GENIX 110	230v	MULTIPLE OPTIONS	115/8	0.32	2.3	277 x 178 x 456	10.3	020-749
GENIX 130	230v	MULTIPLE OPTIONS	115/8	0.32	2.3	277 x 178 x 456	10.6	020-752
GENIX COMFORT 110	230v	MULTIPLE OPTIONS	115/8	0.32	2.3	277 x 178 x 456	11.5	020-753
GENIX COMFORT 130	230v	MULTIPLE OPTIONS	115/8	0.32	2.3	277 x 178 x 456	12	020-754

TYPICAL PACKAGE SEWAGE STATIONS



WE CAN BUILD SEWAGE VESSELS TO YOUR SPECIFICATIONS

SEWAGE & WASTE

PACKAGE SEWAGE STATIONS

We are happy to build any type or size of sewage station using any of the pumps, vessels and control panel combinations.

WHAT YOU NEED TO CONSIDER:

1. AMOUNT OF LIQUID TO BE TRANSFERRED _____ NUMBER OF PEOPLE @ 180LT/DAY _____
To allow for 24 Hour back up guidelines, multiply result above by 2 _____
2. MAXIMUM TOTAL HEAD AND DISTANCE TO MAIN SEWER _____
3. TYPE OF PUMP AND NUMBER OF PUMPS REQUIRED _____
4. SIZE/TYPE OF VESSEL REQUIRED _____ GRP OR POLYETHELENE
(At least one metre depth below the selected outlet level required)
5. TYPE OF PANEL REQUIRED _____
(See pages 74-78)
6. TYPE, NUMBER AND LENGTH OF FLOATS REQUIRED _____
(See pages 82-87)
7. VALVES, FITTINGS AND INTERNAL PIPEWORK _____
(See pages 194-204)
8. DISCHARGE PIPE TO MAIN _____
9. DISCHARGE CONNECTION AND SIZE REQUIRED – MDPE COMPRESSION FITTING OR HOSETAIL OR PVC SOLVENT WELD CONNECTOR _____

IF IN DOUBT PLEASE DO NOT HESITATE TO CALL OUR SALES STAFF WHO WILL BE HAPPY TO ADVISE YOU ON THE CORRECT SELECTION OF EQUIPMENT REQUIRED.

PLEASE NOTE THAT SEWAGE PACKAGE STATIONS WILL REQUIRE SOME ON-SITE ASSEMBLY.

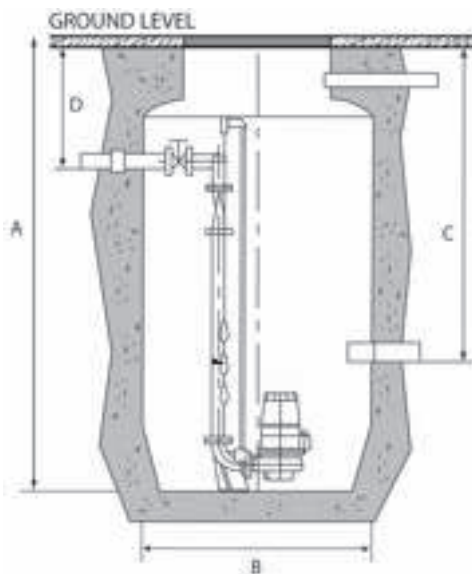

ITEM	INDEX	DEPTH (mm)	DIAMETER (mm)
TANK DEPTH	A		
TANK DIAMETER	B		
DISCHARGE	D		

WE CAN BUILD SEWAGE VESSELS TO YOUR SPECIFICATIONS

SEWAGE PACKAGE VESSELS

A

Vessels complete with access cover. Inlet & Outlet to customer specifications. Working volume is based on inlet pipe at 500mm invert. All vessels have branched bottom to avoid sludge build up. Please Note: Dimensions are external measurements. Common sizes listed below. Other diameters and depths available. Delivery charges vary, dependant on location and size of vessel. Due to so many variants in pumps and pipework, fixed, non fixed, 2", 3", 4" pumps we now offer a price on the full sewage package station. Please ensure you have answered all questions on page 97 so we can process you a quote as soon as possible. Bare vessels are available, contact us for up-to-date prices.



POLYETHELENE EXAMPLE



GRP EXAMPLE

SIZE (DIA X DEPTH)	WORKING VOLUME (Nominal)	GRP CODE	POLYETHELENE CODE
1m x 1m	400 lt	020-246	020-200
1m x 2m	1100 lt	020-248	020-204
1.2m x 1.5m	1220 lt	020-254	020-208
1.2m x 2m	1800 lt	020-255	020-212
1.5m x 1.5m	1760 lt	020-249	020-216
1.5m x 2m	3100 lt	020-250	020-220
1.8m x 2m	3820 lt	020-252	020-224

SEWAGE & WASTE

VACUSYSTEM SEWAGE STATION SINGLE PUMP 230v

E

Single Vacusystem models are small basic package stations. Supplied with the Biox range of pumps. Operation by single integral float switch. Includes non return valve and quick release coupling, three 4" 100mm knockout inlets. Being plastic moulded, holes can be drilled to suit. No control panel is included. Outlet discharge is 2" bsp female thread as standard to allow onsite requirements. If the pump is not suited to the application, please contact our sales representatives for information on other models of pump that can be installed.



ADAPTER

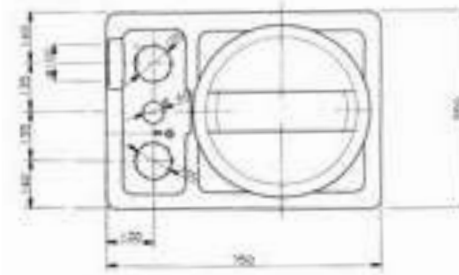

MODEL	FLOW L/M	HEAD (M)	MAX TEMP	VESSEL LITRE	WASTE WATER	SEWAGE WASTE	SOLIDS	POWER	CODE
VS-170-B300	300	10	50°C	170	YES	YES	40mm	1.3 Kw	214-1040
VS-170-B400	400	12	50°C	170	YES	YES	40mm	1.6 Kw	214-1050
110mm – 100mm Adapter (if required)									214-1200

VACUSYSTEM SEWAGE STATION TWIN PUMP 230v & 400v

E

Moulded one piece sump with twin pumps and full control panel for operation as alternative duty and assist, floats included. Supplied with the PrioX range of pumps. Includes non return valves and quick release couplings, three 4" 100mm knockout inlets. Being plastic moulded, holes can be drilled to suit. Full control panel with duty changeover and assist facilities. Outlet discharge is two 2" bsp female thread as standard to allow onsite manifold requirements to be built. If the pumps are not suited to the application, please contact our sales representatives for information on other models of pump that can be installed.

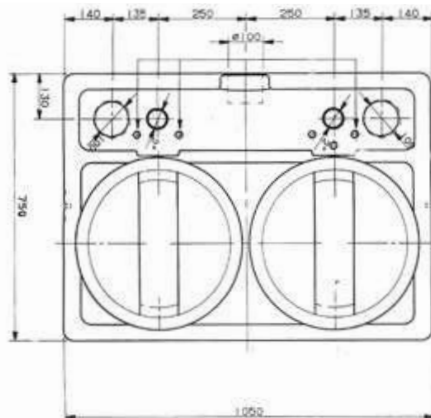

MODEL	FLOW L/M	HEAD (M)	MAX TEMP	VESSEL LITRE	WASTE WATER	SEWAGE WASTE	SOLIDS	POWER	CODE
SINGLE PHASE 230v MODELS									
VS400TP420M	420	11	50°C	400	YES	YES	40mm	2 x 1.3 Kw	214-1120
THREE PHASE 400v MODELS									
VS400TP460T	460	13	50°C	400	YES	YES	40mm	2 x 1.45 Kw	214-1130
110mm – 100mm Adapter (if required)									214-1200

ENGINE DRIVEN PUMPS

KOSHIN

In 1948, KOSHIN Ltd was founded in the ancient city Kyoto, Japan. Since then, Koshin is now one of the world's biggest and most professional Japanese engine pump manufacturers and has been renowned for over 70 years for its production partnerships with petrol and diesel manufacturers such as Suzuki, Mitsubishi, Robin, Yanmar and Honda. Clean and black water pumps, Semi Trash, Full Trash Duty, 1"– 4" are all available from this high quality engine pump supplier.



PETROL ENGINE DRIVEN PUMPS

ENGINE PUMPS, HONDA POWERED, RECOIL START

C

KOSHIN has been striving in the manufacture of products for agriculture, construction, industrial, marine, and household and is used in 160 countries and counts around 30% global market share. Ideal for clean and black water applications, construction and agricultural duties. Heavy duty build. STH are semi trash pumps with spheroidal graphite iron impeller and volutes and also a SIC mechanical seal for aggressive applications.

Features

Honda Engine Driven
4 Stroke
Self Priming

Applications

Drainage
Hire
Utilities



SEH-25L



SEH-25H

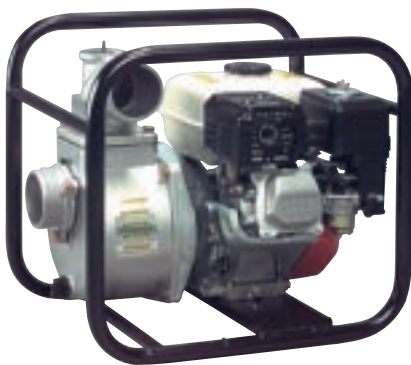

SEH-80X



STH-80X

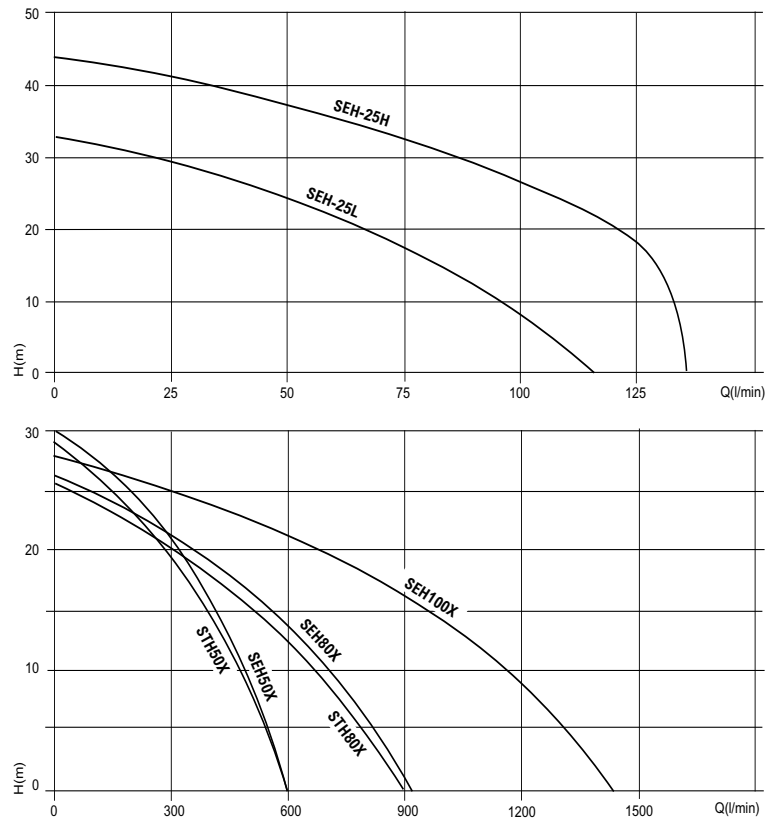

MODEL	ENGINE	OIL ALERT	ELECTRIC START	INLET/OUTLET	LM/HM	SOLIDS	H x W x L mm	Kg	CODE
SEH-25L	GX25 2.0HP	NO	NO	1" x 1"	115/32	5mm	330 x 375 x 235	7.0	050-016
SEH-25H	GXH50 2.0HP	NO	NO	1" x 1"	135/43	5mm	453 x 311 x 385	15.0	050-015
SEH-50X	GX120 4.0HP	YES	NO	2" x 2"	620/30	5mm	420 x 360 x 465	24.0	050-022
SEH-80X	GX160 5.5HP	YES	NO	3" x 3"	900/26	7mm	458 x 389 x 525	32.0	050-032
SEH-100X	GX240 8.0HP	YES	NO	4" x 4"	1450/28	9mm	669 x 477 x 670	55.0	050-038
STH SEMI TRASH									
STH-50X	GX120 4.0HP	YES	NO	2" x 2"	600/29	8mm	415 x 395 x 500	25	050-028
STH-80X	GX160 5.5HP	YES	NO	3" x 3"	900/26	9mm	473 x 389 x 525	35	050-048

PETROL ENGINE DRIVEN PUMPS

ENGINE PUMPS, KOSHIN K SERIES POWERED

C

KOSHIN, one of the world's biggest and most professional engine pump manufacturers have been renowned for over 50 years for its production partnerships with petrol and diesel engine manufacturers such as Suzuki, Mitsubishi, Robin, Yanmar and Honda. KOSHIN has produced 2 ranges of Engine pumps powered by its own K series engine. The SEV25L, SEV50X and SEV80X are for clean and black water duties.

Features

Engine Driven
4 Stroke (Except SEV25L)
Self Priming

Applications

Drainage
Hire
Utilities



SEV-25L

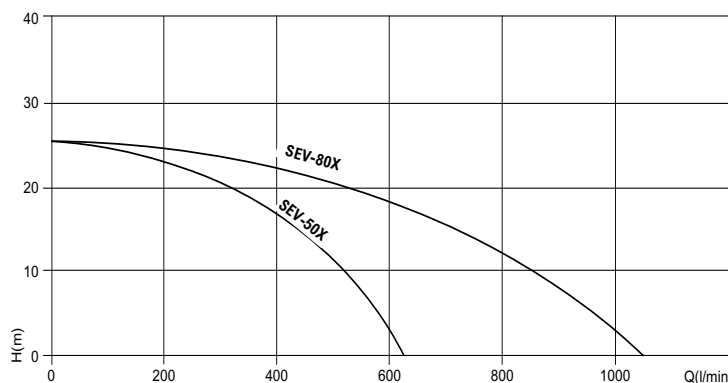
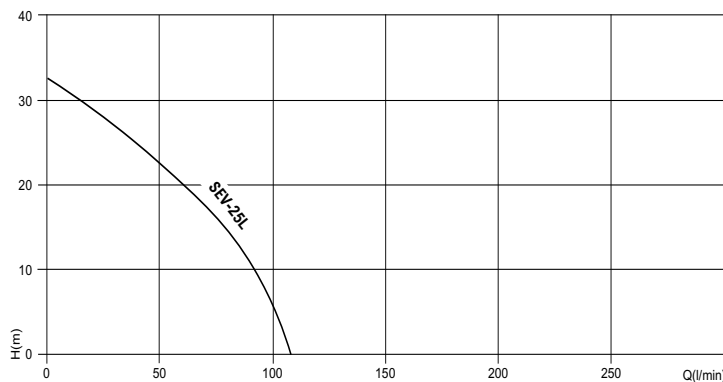

SEV-80X

MODEL	ENGINE	OIL ALERT	ELECTRIC START	INLET/OUTLET	LM/HM	SOLIDS	H x W x L mm	Kg	CODE
SEV-25L	KC26 2.0HP*	NO	NO	1" x 1"	110/32	5mm	300 x 230 x 350	5.5	050-000
SEV-50X	K180 4.0HP	YES	NO	2" x 2"	620/25	5mm	427 x 360 x 460	26.0	050-002
SEV-80X	K180 4.0HP	YES	NO	3" x 3"	1050/25	7mm	458 x 389 x 525	30.0	050-004

*2 Stroke.

DIESEL ENGINE DRIVEN PUMPS

DIESEL ENGINE POWERED CENTRIFUGAL PUMPS

C

SE50XDHR/HES & SE80XDHR/HES deliver high volumes of water powered by a strong and durable Hatz diesel engine. Operation costs are reduced by using this economical diesel engine. Pump sets are assembled here in the UK and offer recoil start or recoil/ electric start options. These also come in a sturdy roll over steel pipe frame and wheel kit for making more portable to move around.

Features

- Engine Driven
- Electric Start Options
- Self Priming

Applications

- Drainage
- Hire
- Utilities

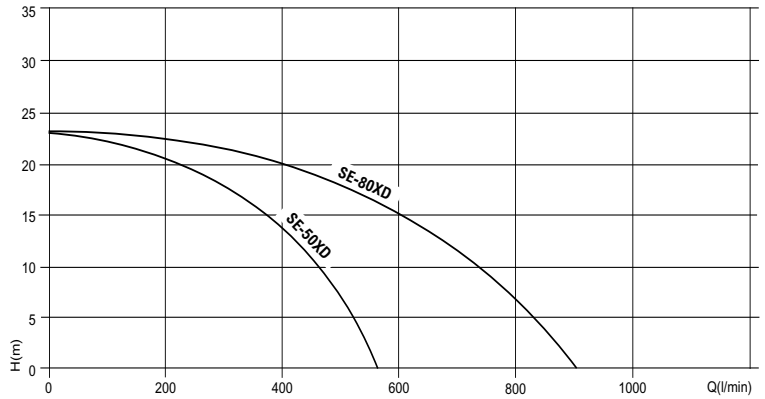

SE-50XDHES



MODEL	ENGINE	OIL ALERT	ELECTRIC START	INLET/OUTLET	LM/HM	SOLIDS	H x W x L mm	Kg	CODE
SE-50XDHR*	HATZ 1B20 5.0HP	NO	NO	2" x 2"	560/23	5mm	710 x 700 x 800	55.0	050-070HR
SE-80XDHR*	HATZ 1B20 5.0HP	NO	NO	3" x 3"	900/23	7mm	710 x 700 x 800	58.0	050-075HR
SE-50XDHES*	HATZ 1B20 5.0HP	NO	YES	2" x 2"	560/23	5mm	710 x 700 x 800	65.0	050-070HES
SE-80XDHES*	HATZ 1B20 5.0HP	NO	YES	3" x 3"	900/23	7mm	710 x 700 x 800	68.0	050-075HES

*Complete with Crash Frame & Wheel Kit.

DIESEL DRIVEN PUMPS

DIESEL ENGINE POWERED CENTRIFUGAL PUMPS

SE50XD YR & SE80XD YR self priming diesel engine driven water pumps. Featuring aluminum pump body, cast iron impeller and volute. Suitable for pumping clean and black water. Powered by Yanmar L48V diesel engine. All models are housed within a protective tubular carry frame complete with hose couplings, clips and strainer.

Features

Engine Driven
Self Priming

Applications

Drainage
Hire
Utilities

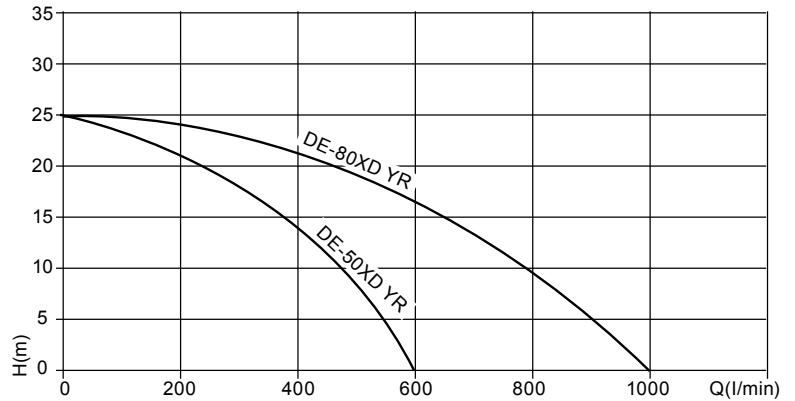

DE-50XD YR



DE-80XD YR



MODEL	ENGINE	OIL ALERT	ELECTRIC START	INLET/OUTLET	LM/HM	SOLIDS	H x W x L mm	Kg	CODE
DE-50XD YR	YANMAR L48V 4.6 HP	NO	NO	2" x 2"	600/25	5mm	560 x 445 x 640	47	050-070 DUYP
DE-80XD YR	YANMAR L48V 4.6 HP	NO	NO	3" x 3"	1000/25	7mm	560 x 445 x 640	51	050-075 DUYP

ENGINE DRIVEN PUMPS

DIESEL ENGINE POWERED TRASH PUMPS

Cast iron trash water pumps complete with an inspection door to remove any blockages that may occur. A non return valve is fitted on the inlet of the pump to avoid the loss of water after the pump has stopped, making it easier to prime when the pump starts again. Maximum suction depth 6 metres. Silicon carbide seal. Driven by a Yanmar diesel engines. Model B2KQA-ST YR comes complete in a crash frame. Models B3QA-ST YR/YES & B4QA-ST YES comes complete in a crash frame and wheel kit (wheel kit and handles need to be assembled upon delivery)

Features

Engine Driven
Self Priming

Applications

Drainage
Hire
Utilities

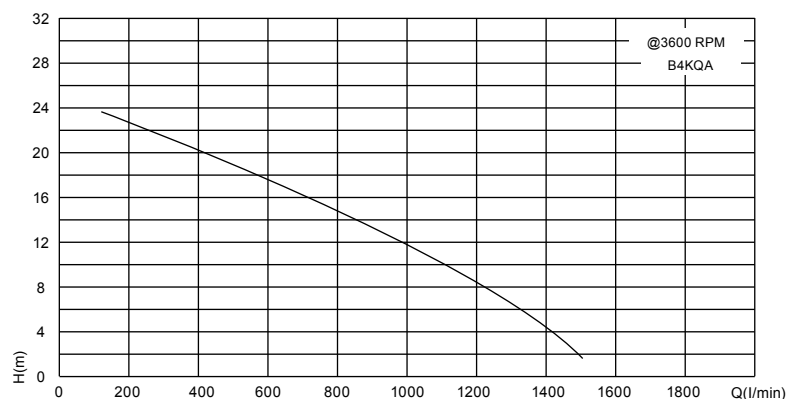
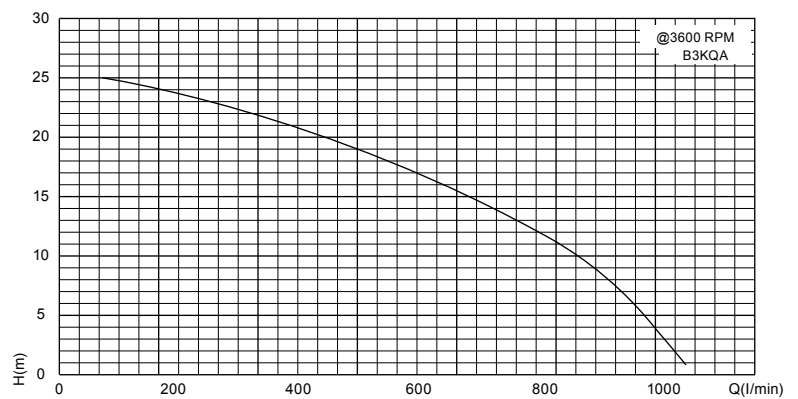
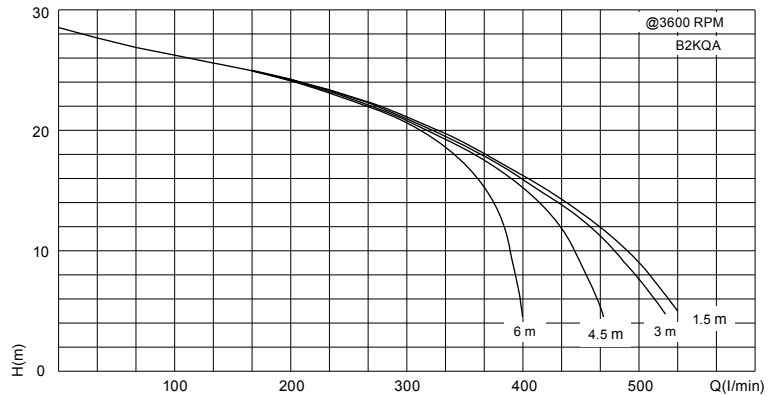

MODEL	ENGINE	OIL ALERT	ELECTRIC START	INLET/OUTLET	LH/HM	SOLIDS	H x W x L mm	Kg	CODE
B2KQA-STYR	YANMAR L48V6 3.1 Kw	NO	NO	2" x 2"	530/28	16mm	715 x 670 x 670	56.5	050-100
B3KQA-STYR	YANMAR L70V 4.8 Kw	NO	NO	3" x 3"	1030/24	27mm	715 x 670 x 670	68.5	050-110
B3KQA-STYES	YANMAR L70V 4.8 Kw	NO	YES	3" x 3"	1030/24	27mm	717 x 670 x 800	79	050-115
B4KQA-STYES	YANMAR L100V6 6.8Kw	NO	YES	4" x 4"	1510/24	28mm	820 x 670 x 950	121	050-125

ENGINE DRIVEN PUMPS

ENGINE POWERED HIGH PRESSURE POWERED PUMPS

C

Honda powered high pressure pumps, compact in design with excellent flow and high pressure they are suitable for irrigation, transfer and dust suppression. Pumps sets using the Hatz diesel range of engine pumps are assembled to order and offer recoil start or recoil/electric start options. These also come in a sturdy crash frame and wheel kit for making them more portable to move around.

Features

Engine Driven
Honda Petrol or Hatz Diesel
Electric Start Options
Self Priming

Applications

Drainage
Hire
Utilities

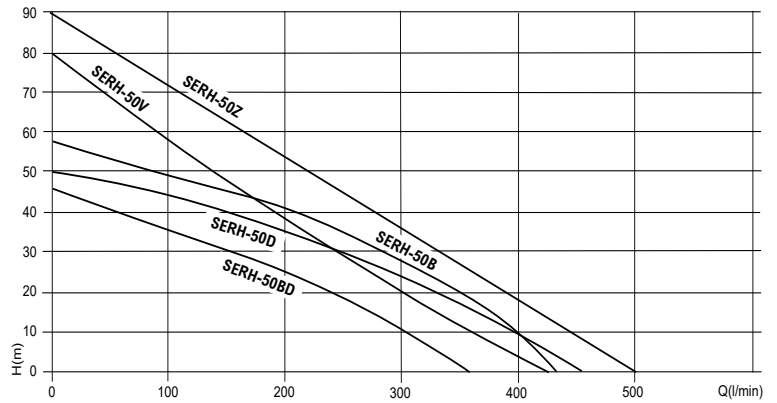

SERH-50B



SERH-50V/50Z



SERH-50BDHES

MODEL	ENGINE	OIL ALERT	ELECTRIC START	INLET/OUTLET	LM/HM	SOLIDS	H x W x L mm	Kg	CODE
SERH-50B	GX160 5.5HP	YES	NO	2" x 2"	440/57	1mm	440 x 405 x 535	35.0	050-042
SERH-50V	GX160 5.5HP	YES	NO	2" x 2"	430/80	1mm	468 x 450 x 555	39.0	050-045
SERH-50Z	GX200** 6.5HP	YES	NO	2" x 2"	500/90	1mm	468 x 450 x 570	37.6	050-046
SERH-50BDHR*	HATZ 1B20 5.0HP	NO	NO	2" x 2"	350/45	1mm	710 x 700 x 800	55.0	050-043HR
SERH-50DHR*	HATZ 1B30 7.0HP	NO	NO	2½" x 2"	450/49	1mm	710 x 700 x 800	60.0	050-044HR
SERH-50BDHES*	HATZ 1B20 5.0HP	NO	YES	2" x 2"	350/45	1mm	710 x 700 x 800	60.0	050-043HES
SERH-50DHES*	HATZ 1B30 7.0HP	NO	YES	2½" x 2"	450/49	1mm	710 x 700 x 800	65.0	050-044HES

*Complete with Crash Frame & Wheel Kit

** Hi-Revolution.

ENGINE DRIVEN PUMPS

ENGINE POWERED TRASH DUTY PUMPS

C

Honda Petrol engine & Hatz Diesel engine trash duty pumps for sewage and muck. Large easy off front cover for cleaning. SIC mechanical seals and Hi Chrome Impeller and Spheroidal Graphite Iron volute. Pumps sets using the Hatz diesel range of engine pumps are assembled to order and offer recoil start or recoil/electric start options. These also come in a sturdy roll over steel pipe frame and wheel kit for making them more portable to move around.

Features

- Engine Driven
- Honda Petrol or Hatz Diesel
- Electric Start Options
- Self Priming

Applications

- Drainage
- Hire
- Utilities



KTH-50X



KTH-80S



KTH-80DHES

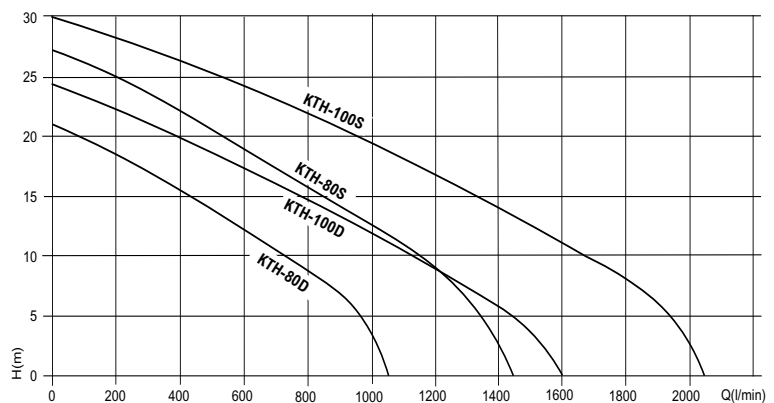
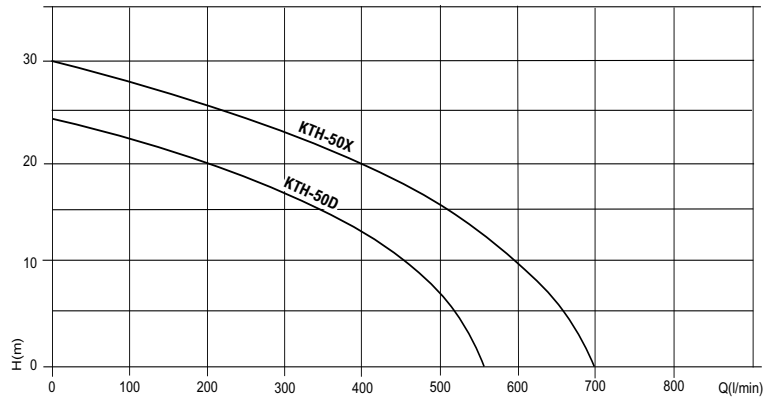

MODEL	ENGINE	OIL ALERT	ELECTRIC START	INLET/OUTLET	LM/HM	SOLIDS	H x W x L mm	Kg	CODE
KTH-50X	HONDA GX160 5.5HP	YES	NO	2" x 2"	700/30	20mm	524 x 498 x 656	51	050-074
KTH-80S	HONDA GX240 8.0HP	YES	NO	3" x 3"	1450/27	27mm	570 x 495 x 690	67	050-076
KTH-100S	HONDA GX340 11.0HP	YES	NO	4" x 4"	2050/30	30mm	600 x 540 x 745	83	050-078
KTH-50DHR*	HATZ 1B20 5.0HP	NO	NO	2" x 2"	560/24	20mm	710 x 700 x 800	54	050-052HR
KTH-80DHR*	HATZ 1B30 7.0HP	NO	NO	3" x 3"	1160/21	27mm	710 x 700 x 800	99	050-082HR
KTH-100DHR*	HATZ 1B40 8.5HP	NO	NO	4" x 4"	1640/24	30mm	820 x 700 x 1300	140	050-087HR
KTH-50DHES*	HATZ 1B20 5.0HP	NO	YES	2" x 2"	560/24	20mm	710 x 700 x 800	54	050-052HES
KTH-80DHES*	HATZ 1B30 7.0HP	NO	YES	3" x 3"	1160/21	27mm	710 x 700 x 800	99	050-082HES
KTH-100DHES*	HATZ 1B40 8.5HP	NO	YES	4" x 4"	1640/24	30mm	820 x 700 x 1300	140	050-087HES

*Complete with Crash Frame & Wheel Kit.

ENGINE DRIVEN PUMPS

KOSHIN PARTS

When it comes to maintenance and repair, Koshin believes that consumers should be able to replace parts at a fair and reasonable cost. Unlike other manufacturers and distributors who charge premium prices for spare parts discourage service and repair. Koshin with consumers in mind do not charge premium prices on their spare parts. A recent comparison found that other manufacturers and distributors charge over 100's of a percent more than a Koshin spare part.



COMMON SPARE PARTS FOR KOSHIN ENGINE PUMPS

CENTRIFUGAL SERIES

C

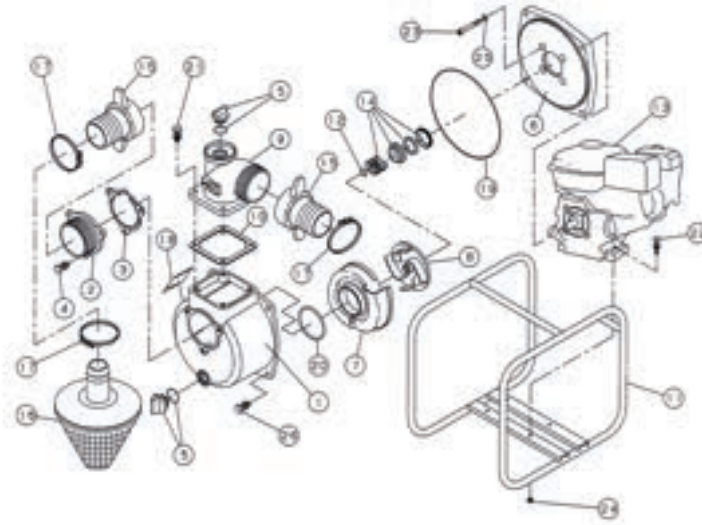

PART	1	2	3	5a	5b	6	7	8	9	10	14	15	19	20
MODEL	PUMP CASE	SUCTION FLANGE	CHECK VALVE	DRAIN BUNG	FILLER BUNG	FLANGE BRACKET	VOLUTE	IMPELLER	DELIVERY FLANGE	GASKET	SEAL	HOSE TAILS EACH	O RING CASE	O RING VOLUTE
SEM-25L TU-26	0113329 050-960	0113325 050-966	0113326 050-967	0148010 050-600	0118450 050-973	0115987	0115986	0115985	N/A	N/A	0116054	0348015 050-952	890255031 050-969	889855042 050-972
SEH-25L GX-25	0113329 050-960	0113325 050-966	0113326 050-967	0148010 050-600	0118450 050-973	0114992 050-963	0112528 050-964	0114994	N/A	N/A	0116054	050-952	8902550 050-969	8898550 050-972
SEH-25H GXH-50	0113330 050-940	0114002 050-947	0113328 050-948	0118078 050-604	0118078 050-604	0116926	0116994	0116937	0111449 050-949	0110593 050-950	0110685 050-842	0348015 050-952	890255043 050-953	889855048 050-954
*SEH-50X GX120-OLD	0112578 050-684	0112662 050-644	0112665 050-664	0118078 050-604	0118078 050-604	0112579 050-864	0113175 050-743	0111780 050-804	0110556 050-704	0110541 050-724	0110688 050-844	0117026 050-624	0115014 050-784	011279201 050-764
*SEH-50X GX120-NEW	0112578 050-684	0112662 050-644	0112665 050-664	0118078 050-604	0118078 050-604	0112579 050-864	0114640 050-744	0113532 050-805	0110556 050-704	0110541 050-724	0110688 050-844	0117026 050-624	0115014 050-784	011279201 050-764
SEH-50X GX120 BEJ	0112578 050-684	0112662 050-644	0112665 050-664	0118078 050-604	0118078 050-604	0115268	0114640 050-744	0116616	0110556 050-704	0110541 050-724	0114090	0117026 050-624	0115014 050-784	011279201 050-764
*SEH-80X GX-160 OLD	0112795 050-686	0112797 050-646	0112799 050-666	0118078 050-604	0118079 050-607	0112796 050-866	0113176 050-746	0110532 050-806	0110570 050-706	0110584 050-726	0110664 050-846	0117028 050-626	0115015 050-786	0113989 050-766
*SEH-80X GX-160 NEW	0112795 050-686	0112797 050-646	0112799 050-666	0118078 050-604	0118079 050-607	0112796 050-866	0114379 050-747	0114376 050-807	0110570 050-706	0110584 050-726	0110664 050-846	0117028 050-626	0115015 050-786	0113989 050-766
SEH-80X GX-160 BFD	0112795 050-686	0112797 050-646	0112799 050-666	0118078 050-604	0118079 050-607	0115269	0114379 050-747	0116617	0110570 050-706	0110584 050-726	0114090	0117028 050-626	0115015 050-786	0113989 050-766
STH-50X GX-120	0112578 050-684	0112662 050-644	0112665 050-664	0118078 050-604	0118078 050-604	0114027	0115169	0115168	0110556 050-704	0110541 050-724	0115159	0117026 050-624	0115014 050-784	011279201 050-764
STH-80X GX-160	0112795 050-686	0112797 050-646	0112799 050-666	0118078 050-604	0118079 050-607	0112796 050-866	0115541	0115539	0110570 050-706	0110584 050-726	0115159	0117028 050-626	0115015 050-786	0113989 050-766
SERH-50B GX160	0114001 0114184 050-692	0114003 050-650	0112799 050-666	0118079 050-607	0118078 050-604	0110568 050-870	0112818 050-750	0112861 050-810	0114209 050-712	0110584 050-726	0110863 050-846	Ask For Details	0115016 050-792	0113989 050-766
SERH-50 GX240		0114004 050-652	0112799 050-666	0118079 050-607	0118078 050-604	0110722 050-872	0112819 050-752	0112862 050-812	0114209 050-712	0110584 050-726	0110862 050-852	Ask For Details	0115016 050-792	0113989 050-766
SERH-50V GX160	0120393	0120394	0120398	0118078 050-604	0118078 050-604	0120396	0120390	0117990	0120395	0120399	0120389	Ask For Details	0115016 050-792	889855056

*Discontinued models – limited spare parts available.

COMMON SPARE PARTS FOR KOSHIN ENGINE PUMPS

KTH TRASH PUMP SPARES

C

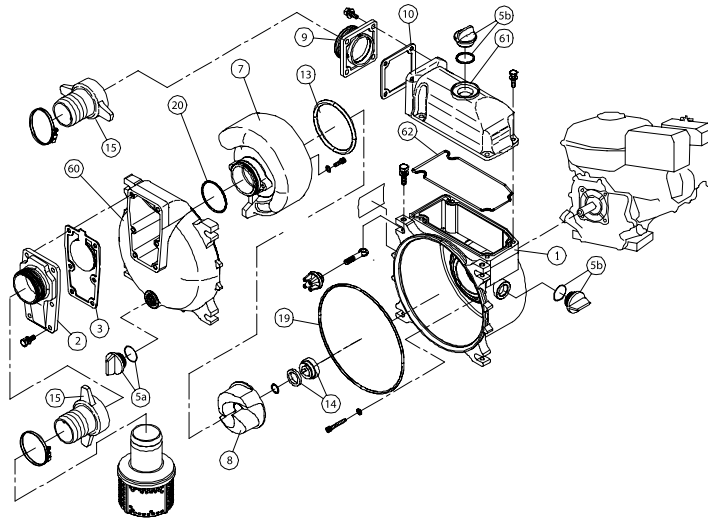

PART MODEL	1 PUMP CASE	2 SUCTION FLANGE	3 CHECK VALVE	5a DRAIN BUNG	5b FILLER BUNG	7 VOLUTE	8 IMPELLER	9 DELIVERY FLANGE	10 GASKET	13 CASING PACKING	14 SEAL	19 O RING CASE	20 O RING VOLUTE	60 FRONT COVER	61 DELIVERY HOUSING	62 HEAD PACKING
KTH-50X	0115446	0115839	0115780	0118079 050-607	0118450 050-973	0115489 SEE NOTES	0115447	0115840	0115490	0115578	0115159	0115579	0115676	0115545 SEE NOTES	0115445	0115548
KTH-80X*	0115546	0111573	0115692	0118079 050-607	0118450 050-973	0115559	0115558	0115838	0110584 050-726	0115578	0115678	0115579	0115676	0115545	0115547	0115548
KTH-100X*	0116150	0116268	0118261	0118079 050-607	0118450 050-973	0116488	0115626	0116188	0110750	N/A	0115678	0115579	0116270	0116490	0116148	0115548

*Discontinued models, for S version model spares see page 105.

Notes - 0115489 Volute Discontinued. Use new code 0121897. This new part will not fit together with 0115545 front cover. 0115545 - Discontinued. Use new code 0212900. This new part will not fit together with 0115489 Volute. If 0115545 or 0115489 needs replacing then both items 0121897 & 0212900 will be required

THERMOPLASTIC PUMP SPARES

C

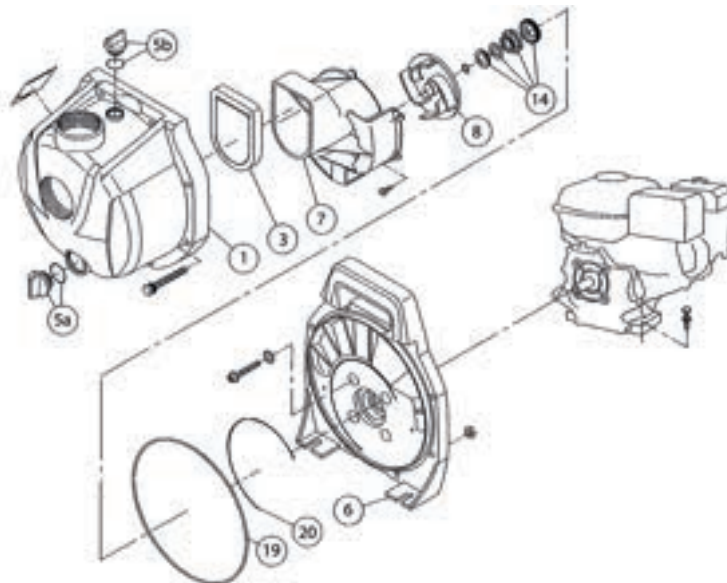

PART MODEL	1 PUMP CASE	2 SUCTION FLANGE	3 CHECK VALVE	5a DRAIN BUNG	5b FILLER BUNG	6 FLANGE BRACKET	7 VOLUTE	8 IMPELLER	9 DELIVERY FLANGE	10 GASKET	14 SEAL	19 O RING CASE	20 O RING VOLUTE	60	61	62
PGH-50	0130024	N/A	0130009	050-604	050-604	0130002	0130003	0130004	N/A	N/A	0130011	0130005	0130008	N/A	N/A	N/A

COMMON SPARE PARTS FOR KOSHIN ENGINE PUMPS

KTH S TRASH PUMP SPARES

C

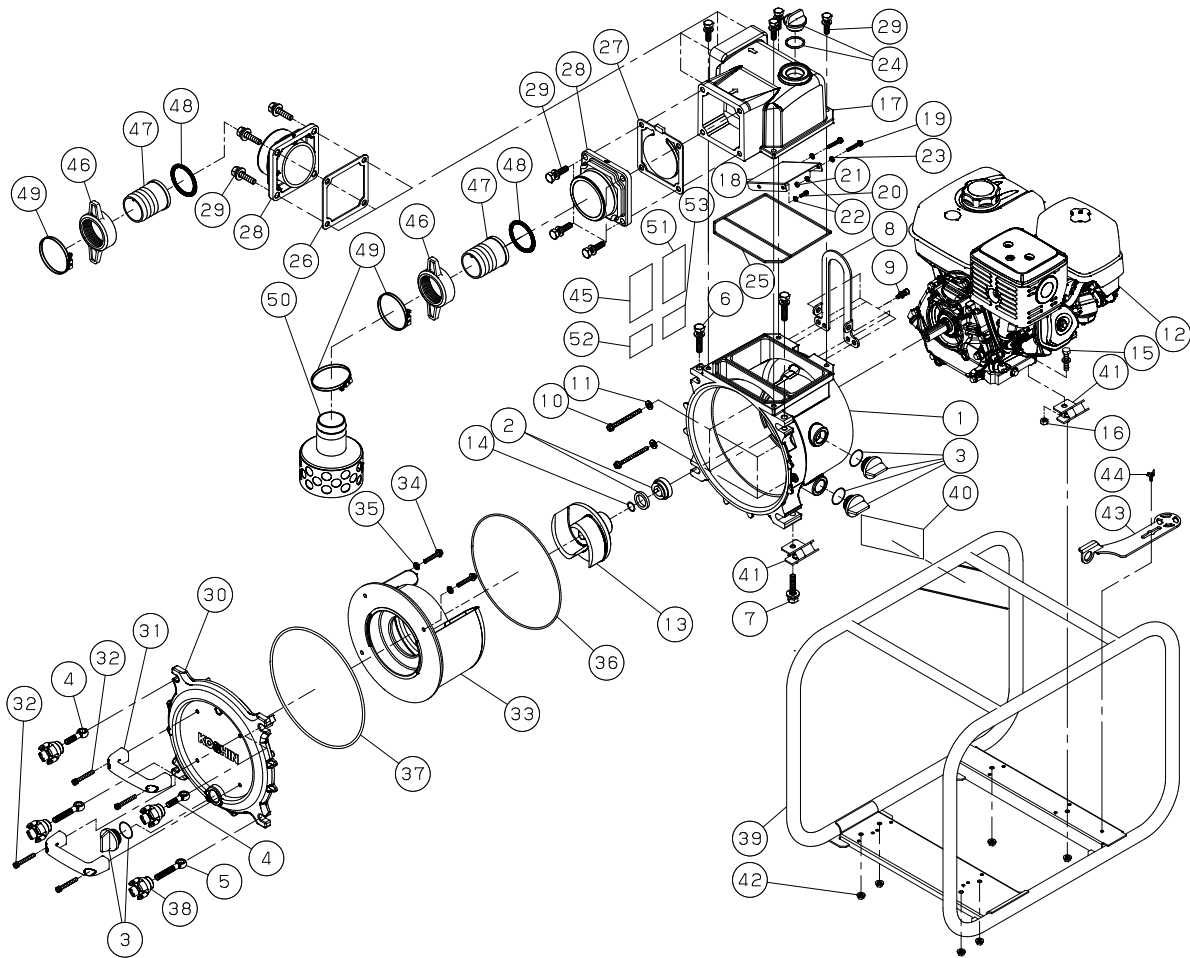

PART	1	2	3	13	24	25	26	27	28	30	33	36	37	46/47/48
MODEL	PUMP CASE	MECH SEAL	DRAIN BUNG	IMPELLER	FILLER BUNG	HEAD PACKING	FLANGE PACKING	CHECK VALVE	SUC/DEL FLANGE	FRONT COVER	VOLUTE CASE	VOLUTE O RING	CASE O RING	HOSE TAIL
KTH-80S	0121439	0115678	0118079	0121438	0118450	0121450	0110584	0121574	0115838	0121440	0121441	0121917	0121916	0118015
			050-607		050-973		050-726							
KTH-100S	0121442	0115678	0118079	0121436	0118450	0121450	0110750	0121577	0116188	0121443	0121444	0121917	0121916	0117639
			050-607		050-973									



ENGINE DRIVEN PUMPS

ENGINE POWERED THERMOPLASTIC PUMPS

C

Honda petrol and Hatz diesel powered engine pumps are self-priming for the transfer of non-abrasive, but aggressive liquids that would normally cause corrosion of the aluminium and cast iron components normally found in standard engine driven pumps. They are constructed from polyethylene terephthalate, EPDM o rings and rubber of the carbon ceramic mechanical seal. Stainless steel for all bolts and washers. The standard construction will handle most detergents, many agricultural chemicals and sea salt water. If unsure please contact us.

Features

- Engine Driven
- Honda Petrol or Hatz Diesel
- Electric Start Options
- Self Priming

Applications

- Drainage
- Hire
- Utilities

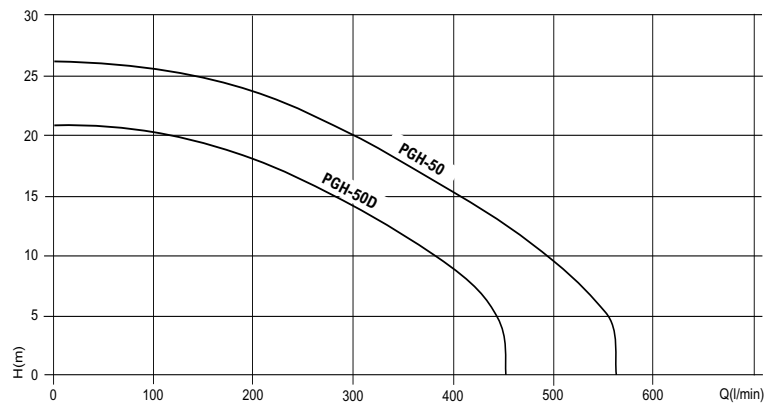

PGH-50



PGH-50D

MODEL	ENGINE	OIL ALERT	ELECTRIC START	INLET/OUTLET	LM/HM	SOLIDS	H x W x L mm	Kg	CODE
PGH-50	HONDA GX120 4.0HP	YES	NO	2" x 2"	560/26	5	476 x 402 x 506	22	050-024
PGH-50DHR*	HATZ 1B20 5.0HP	NO	NO	2" x 2"	450/21	5	710 x 700 x 800	58	050-024DHR
PGH-50DHES*	HATZ 1B20 5.0HP	NO	YES	2" x 2"	450/21	5	710 x 700 x 800	58	050-024DHES

*Complete with Crash Frame & Wheel Kit.

ENGINE DRIVEN PUMPS

DIESEL ENGINE POWERED DIESEL TRANSFER PUMPS

C

Self priming engine driven pump with open impeller to transfer fuels. Suitable for pumping diesel, gas oil, paraffin. NOT FOR PUMPING PETROL. A non-return valve is fitted on the inlet of the pump body to avoid the loss of liquid after the pump has stopped, making it easier to prime when the pump starts again. Maximum suction depth of 6 metres and a maximum liquid temperature of 60°C. Pump casing, inlet flange and impeller are made from cast iron. Stainless steel shaft. Viton mechanical seal and Viton check valve.

Features

Engine Driven
Hatz Diesel
Electric Start Options
Self Priming

Applications

Fuel Oil Transfer
Hire

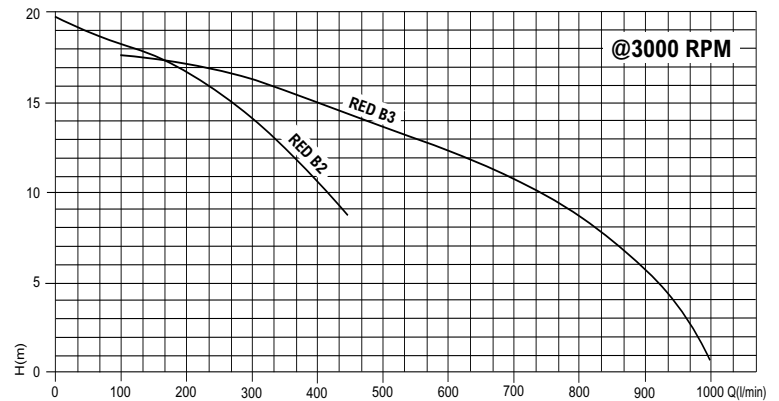

MODEL	ENGINE	OIL ALERT	ELECTRIC START	INLET/OUTLET	LM/HM	SOLIDS	H x W x L mm	Kg	CODE
RED B2KQA HR	HATZ 1B20	NO	NO	2" x 2"	480/19	12	820 x 700 x 1030	50	070-200HR
RED B3KQA HR	HATZ 1B20	NO	NO	3" x 3"	700/17	25	820 x 700 x 1030	60	070-300HR
RED B2KQA HE	HATZ 1B20	NO	YES	2" x 2"	480/19	12	820 x 700 x 1030	50	070-200HE
RED B3KQA HE	HATZ 1B20	NO	YES	3" x 3"	700/17	25	820 x 700 x 1030	60	070-300HE

ENGINE DRIVEN PUMPS

HONDA PETROL POWERED DIAPHRAGM PUMPS

C

Quiet and reliable recoil start Honda overhead valve engine with a low oil sensor. Straight line flow design is self cleaning – eliminates clogging. Pump housing made of lightweight sand cast aluminium, standard wheel kit provides portability. Built to run dry without damage, perfect for areas of slow seepage. New narrow design allows access through doorways and easier storage.

Features

Engine Driven
Honda Petrol
Self Priming

Applications

Mud and Sludge
Hire

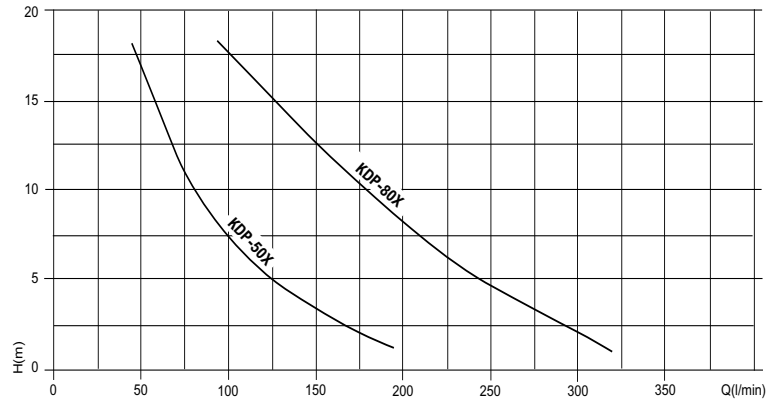

MODEL	ENGINE	OIL ALERT	ELECTRIC START	INLET/OUTLET	LM/HM	SOLIDS	H x W x L mm	Kg	CODE
KPD-50X	HONDA GX120 4.0HP	YES	NO	2" x 2"	190/17	25mm	650 x 430 1200	44	060-870
KPD-80X	HONDA GX120 4.0HP	YES	NO	3" x 3"	330/17	37mm	650 x 430 1200	60	060-880

ENGINE DRIVEN PUMPS

DIESEL POWERED DIAPHRAGM PUMPS

C

Diesel powered diaphragm pump complete with either a Hatz 1B20 recoil or electric start. Reliable straight line flow design – eliminates clogging. Pump housing made of lightweight sand-cast aluminium. Standard wheel kit provides portability. Built to run dry without damage, perfect for areas of slow seepage. New narrow design allows access through doorways and easier storage. 3" diesels come complete with crash frame and mud feet for site duty applications.

Features

Engine Driven
Hatz Diesel
Self Priming

Applications

Mud and Sludge
Hire

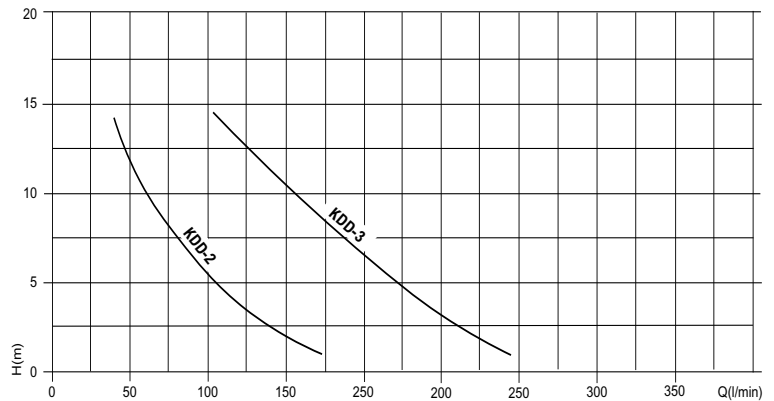

MODEL	ENGINE	OIL ALERT	ELECTRIC START	INLET/OUTLET	LM/HM	SOLIDS	H x W x L mm	Kg	CODE
KDD-2R	HATZ 1B20 5.0HP	NO	NO	2" x 2"	150/13.5	25mm	670 x 430 x 1200	91	060-872
KDD-3R	HATZ 1B20 5.0HP	NO	NO	3" x 3"	260/13.5	37mm	670 x 430 x 1200	94	060-882
KDD-2E	HATZ 1B20 5.0HP	NO	YES	2" x 2"	150/13.5	25mm	670 x 430 x 1200	94	060-874
KDD-3E	HATZ 1B20 5.0HP	NO	YES	3" x 3"	260/13.5	37mm	670 x 430 x 1200	98	060-884



Sediment filtration system

- Removes sediment from contaminated water down to 100 micron
- Has a rugged PVC outer sleeve
- Hydrocarbon detection strip to identify oil pollution
- Retains approx 20 Kg of sediment
- Lightweight and compact
- Highly visible
- Straps for easy lifting
- Highly reusable
- Very easy to empty and wash through

Budget sediment filter

- Simple low cost and effective
- Removes sediment from contaminated water
- Retains approximately 20 Kg of sediment
- Very lightweight and compact
- Highly visible collar
- Straps for easy lifting
- Can be reused



Oil & Sediment filter

- Same uses as above but for the removal of sediment and oil sheen from pumped water
- Can remove up to 2.5 litres of oil

Evac filtration system

- Removes oil sheen and sediment from contaminated water down to non-detectable levels
- Sediment to as low as 1 micron
- Comes with a cam lock fitting for high pressure pumping
- Hydrocarbon detection strip to identify pollution
- Contains C.I Agent Polymer Technology to help remove hydrocarbons



Dewatering packs come in a sealable container with 5, 10 or 15 pillows

- This system contains technology that turns oil into a non leaching rubber so that it can be easily removed from water
- It removes hydrocarbons down to non-detectable levels
- Each polymer pillow solidifies and retains one litre of hydrocarbon within minutes of contact
- Once the pillows have collected the oil, the remediated water can be processed through an oil and sediment filter for a final polish, allowing it to be safely pumped into the environment
- Big cost savings compared to vacuum tankers

MODEL	H x W x L	Kg	CODE
GREEN RHINO BUDGET SEDIMENT FILTER	5 x 35 x 135	0.4	015-100
GREEN RHINO SEDIMENT FILTER	5 x 35 x 126	0.3	015-104
GREEN RHINO OIL & SEDIMENT FILTER	5 x 43 x 140	0.75	015-108
EVAC FILTRATION SYSTEM	15 x 35 x 140	2	015-112
GREEN RHINO DEWATERING PACK 5	46 x 34 x 34	3.5	015-116
GREEN RHINO DEWATERING PACK 10	46 x 34 x 34	4.5	015-120
GREEN RHINO DEWATERING PACK 15	46 x 34 x 34	5.5	015-124

ENGINE DRIVEN PUMPS, VILLIERS POWERED

ENGINE POWERED CENTRIFUGAL / TRASH / HIGH PRESSURE PUMPS

C

Villiers 4 stroke engine powered pumps, centrifugal VZB for clean and dirty water applications. Trash VWB for sewage and solids handling with large easy off front cover for easy cleaning. High pressure VHP, twin impeller high pressure pump set.

Features

Engine Driven
Petrol
Self Priming
Centrifugal
Trash
High Pressure

Applications

Drainage
Hire
Utilities



RT25VZB



RT50VZB



RT80VWB

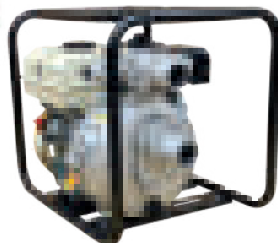

RT50VHP

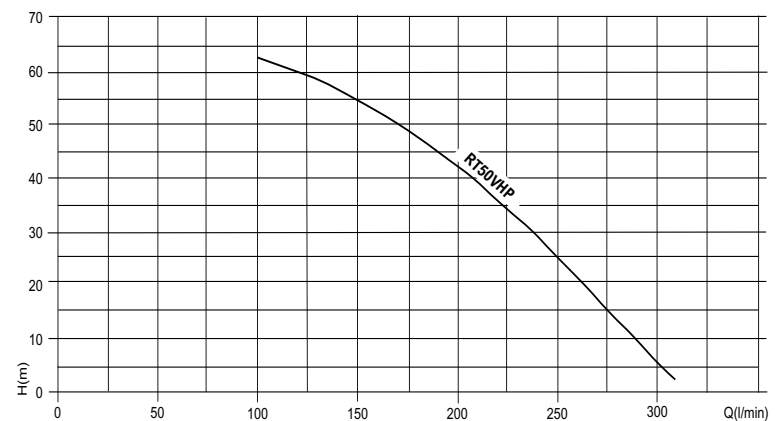
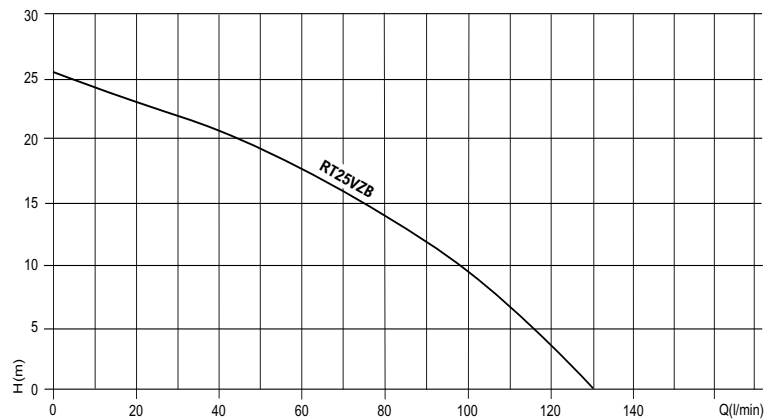
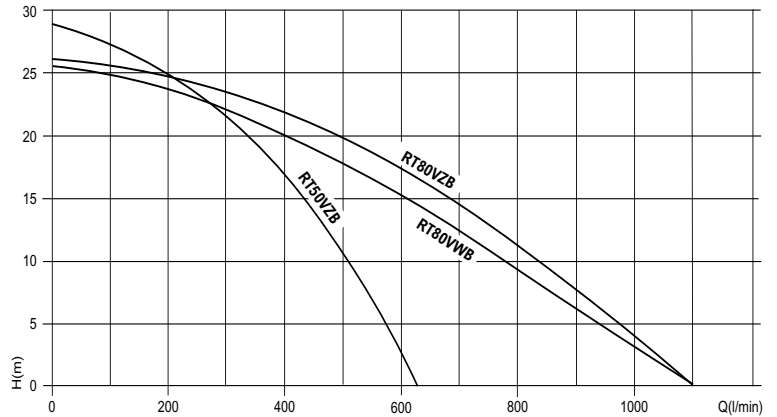

MODEL	ENGINE	OIL ALERT	ELECTRIC START	INLET/OUTLET	LM/HM	H x W x L mm	Kg	CODE
RT25VZB	R80V 2.0HP	YES	NO	1" x 1"	130/26	380 x 290 x 390	14	RT25VZB
RT50VZB	G160V 5.5HP	YES	NO	2" x 2"	600/28	400 x 400 x 480	26	RT50VZB
RT80VZB	G160V 5.5HP	YES	NO	3" x 3"	1000/26	440 x 400 x 500	28	RT80VZB
RT80VWB	G200V 6.5HP	YES	NO	3" x 3"	1110/26	470 x 440 x 560	36	RT80VWB
RT50VHP	G200V 6.5HP	YES	NO	2" x 2"	300/60	430 x 400 x 500	30	RT50VHP

SURFACE MOUNTED PUMPS

SPECIAL BUILDS



We can offer special builds like the examples above.



Contact us for more details.

ACCESSORIES

SUPER ELASTIC MEDIUM DUTY HOSE

A

Strong, flexible and smooth, special super elastic material. For medium duty suction and delivery of water, salt water, light chemicals, liquids in agricultural and industrial applications, sewer purging, sludge, slurries, waste matter, sand and gravel, especially for use in cold climates. This hose will almost lay where you leave it and not try to coil itself back up again.

Sold in 10 and 30 metre coils



SIZE	LENGTH	Kg	WORKING BAR	BURST BAR	CODE
1" 25mm	10m	4.8	7	20	030-342
1" 25mm	30m	14.4	7	20	030-344
1¼" 32mm	10m	5.8	6	17	030-346
1¼" 32mm	30m	17.4	6	17	030-348
1½" 38mm	10m	6.7	5	16	030-350
1½" 38mm	30m	20.1	5	16	030-352
2" 51mm	10m	9.8	5	15	030-354
2" 51mm	30m	29.4	5	15	030-356
2½" 63mm	10m	13.5	4.5	14	030-358
2½" 63mm	30m	40.5	4.5	14	030-360
3" 76mm	10m	17	4	12	030-362
3" 76mm	30m	51	4	12	030-364
4" 102mm	10m	26	3.5	10	030-366
4" 102mm	30m	78	3.5	10	030-368
6" 152mm	10m	50	3	9	030-370
6" 152mm	30m	150	3	9	030-372

ACCESSORIES

SUCTION & DELIVERY HOSE

A

Full Spec High Quality Suction Hose manufactured for use as Suction and Delivery Hose with High Pressure and Vacuum Resistance. Sold by the coil or cut to size.



3/4" 20mm (LIGHT WEIGHT DUTY PVC)

LENGTH	Kg	WORKING BAR	BURST BAR	CODE
Cut p/metre	0.3	6	21	030-320
30m	8.4	6	21	030-321

1" 25mm

LENGTH	Kg	WORKING BAR	BURST BAR	CODE
Cut p/metre	0.48	8	24	030-322
5m	2.4	8	24	030-380
10m	4.8	8	24	030-400
20m	9.6	8	24	030-402
30m	14.4	8	24	030-404
50m	24	8	24	030-406

1 1/4" 30mm

LENGTH	Kg	WORKING BAR	BURST BAR	CODE
30m	17.4	7	21	030-414

1 1/4" 32mm

LENGTH	Kg	WORKING BAR	BURST BAR	CODE
Cut p/metre	0.58	7	21	030-324
6m	3.5	7	21	030-408
10m	5.8	7	21	030-410
20m	11.6	7	21	030-412
30m	17.4	7	21	030-415
50m	29	7	21	030-416

1 1/2" 38mm

LENGTH	Kg	WORKING BAR	BURST BAR	CODE
Cut p/metre	0.67	6	18	030-326
10m	6.7	6	18	030-424
30m	20.1	6	18	030-422

ACCESSORIES

SUCTION & DELIVERY HOSE

A

Full Spec High Quality Suction Hose manufactured for use as Suction and Delivery Hose with High Pressure and Vacuum Resistance. Sold by the coil or cut to size.



2" 50mm

LENGTH	Kg	WORKING BAR	BURST BAR	CODE
Cut p/metre	1	6	18	030-328
6m	6	6	18	030-390
10m	10	6	18	030-426
20m	20	6	18	030-428
30m	30	6	18	030-430
50m	50	6	18	030-432

2½" 65mm

LENGTH	Kg	WORKING BAR	BURST BAR	CODE
Cut p/metre	1.4	5	15	030-329
10m	14	5	15	030-436
30m	42	5	15	030-438

3" 76mm

LENGTH	Kg	WORKING BAR	BURST BAR	CODE
Cut p/metre	1.8	4	12	030-330
6m	10.8	4	12	030-439
10m	18	4	12	030-440
20m	36	4	12	030-442
30m	54	4	12	030-444

4" 102mm

LENGTH	Kg	WORKING BAR	BURST BAR	CODE
Cut p/metre	2.6	4	12	030-332
6m	15.5	4	12	030-447
10m	26	4	12	030-448
20m	52	4	12	030-450
30m	78	4	12	030-452

6" 155mm

LENGTH	Kg	WORKING BAR	BURST BAR	CODE
p/metre	5.1	3	9	030-334
10m	51	3	9	030-456
20m	102	3	9	030-458

ACCESSORIES

LAYFLAT DELIVERY HOSE

A

Sunnyhose is made of synthetic fibres and soft PVC in a continuous one process production. It is a general purpose hose, consistently high in quality, and available in long lengths. It is designed for water supply or drainage, for drip irrigation and sprinkler irrigation at farms, ideal for use as drainage hose in emergency/flood/disaster situations when large quantities of water must be moved quickly.

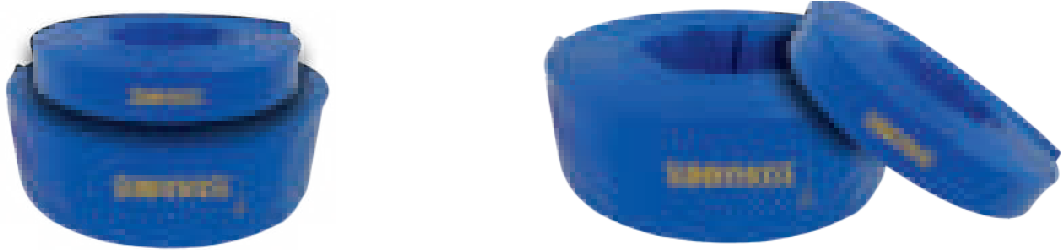

1" 25mm SILVER LINE

LENGTH	Kg	WORKING BAR	BURST BAR	CODE
Cut p/metre	0.165	7	21	030-300
10m	1.65	7	21	SH1-010
20m	3.3	7	21	SH1-020
50m	8.4	7	21	SH1-050
100m	16.5	7	21	SH1-100

1 1/4" 30mm SILVER LINE

LENGTH	Kg	WORKING BAR	BURST BAR	CODE
Cut p/metre	0.2	7	21	030-302
10m	2	7	21	SH14-010
20m	4	7	21	SH14-020
50m	10	7	21	SH14-050
100m	20	7	21	SH14-100

1 1/2" 38mm SUNNY HOSE

LENGTH	Kg	WORKING BAR	BURST BAR	CODE
Cut p/metre	0.15	5	15	030-304
10m	1.5	5	15	SH15-010
20m	3	5	15	SH15-020
50m	8	5	15	SH15-050
100m	15	5	15	SH15-100

2" 50mm SUNNY HOSE

LENGTH	Kg	WORKING BAR	BURST BAR	CODE
Cut p/metre	0.27	4.5	13.5	030-306
10m	2.7	4.5	13.5	SH2-010
20m	5.4	4.5	13.5	SH2-020
30m	8.1	4.5	13.5	SH2-030
50m	13.5	4.5	13.5	SH2-050
100m	27	4.5	13.5	SH2-100

ACCESSORIES

LAYFLAT DELIVERY HOSE

A

Sunnyhose is made of synthetic fibres and soft PVC in a continuous one process production. It is a general purpose hose, consistently high in quality, and available in long lengths. It is designed for water supply or drainage, for drip irrigation and sprinkler irrigation at farms, ideal for use as drainage hose in emergency/flood/disaster situations when large quantities of water must be moved quickly.

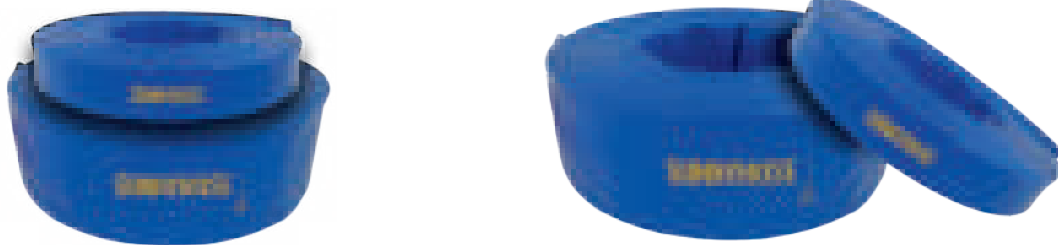

2 1/2" 65mm SUNNY HOSE

LENGTH	Kg	WORKING BAR	BURST BAR	CODE
Cut p/metre	0.39	4	12	030-307
100m	39	4	12	SH25-100

3" 76mm SUNNY HOSE

LENGTH	Kg	WORKING BAR	BURST BAR	CODE
Cut p/metre	0.54	4	12	030-308
10m	5.4	4	12	SH3-010
20m	10.8	4	12	SH3-020
50m	26.5	4	12	SH3-050
100m	53	4	12	SH3-100

4" 102mm SUNNY HOSE

LENGTH	Kg	WORKING BAR	BURST BAR	CODE
Cut p/metre	0.78	4	12	030-310
10m	7.8	4	12	SH4-010
20m	15.6	4	12	SH4-020
30m	23.4	4	12	SH4-030
50m	36	4	12	SH4-050
100m	72	4	12	SH4-100

6" 155mm SUNNY HOSE

LENGTH	Kg	WORKING BAR	BURST BAR	CODE
Cut p/metre	1.2	3	9	030-312
50m	60	3	9	SH6-050
100m	120	3	9	SH6-100

8" 200mm SUNNY HOSE

LENGTH	Kg	WORKING BAR	BURST BAR	CODE
Cut p/metre	1.78	3	9	030-314
50m	89	3	9	SH8-050
100m	178	3	9	SH8-100

ACCESSORIES

LAYFLAT DELIVERY HOSE

A

Sunnyhose is made of synthetic fibres and soft PVC in a continuous one process production. It is a general purpose hose, consistently high in quality, and available in long lengths. It is designed for water supply or drainage, for drip irrigation and sprinkler irrigation at farms, ideal for use as drainage hose in emergency/flood/disaster situations when large quantities of water must be moved quickly. Hi Sunny is more heavy duty, higher burst pressure, greater resistance to abrasion and stronger durability.



10" 250mm SUNNY HOSE

LENGTH	Kg	WORKING BAR	BURST BAR	CODE
Cut p/metre	2.65	2.5	7.5	030-316
50m	132.50	2.5	7.5	SH10-050
100m	265	2.5	7.5	SH10-100

12" 300mm SUNNY HOSE

LENGTH	Kg	WORKING BAR	BURST BAR	CODE
Cut p/metre	2.91	2	6	030-318
50m	145.50	2	6	SH12-050
100m	291	2	6	SH12-100

4" 102mm HI SUNNY HOSE

LENGTH	Kg	WORKING BAR	BURST BAR	CODE
50m	44	6	18	SH4-050HI SUN
100m	88	6	18	SH4-100HI SUN

6" 155mm HI SUNNY HOSE

LENGTH	Kg	WORKING BAR	BURST BAR	CODE
50m	74	6	18	SH6-050HI SUN
100m	149	6	18	SH6-100HI SUN

SELF PRIMING CONTRACTOR PUMPS

GT50 & GT80

B

Self priming electric pump with three blade impeller, suitable for pumping dirty water. This version is provided with a large inspection cover to remove any blockages that may occur, a wear disc made from stainless steel. A non-return valve is fitted on the inlet of the pump body to avoid the loss of water after the pump has stopped, making it easier to prime when the pump starts again. Maximum suction depth of 8 metres and a maximum liquid temperature of 80°C. Pump casing and impeller are made from cast iron. Stainless steel shaft. Silicon carbide seal.

Features

Centrifugal
Self Priming
Cast Iron

Applications

Drainage
Circulation

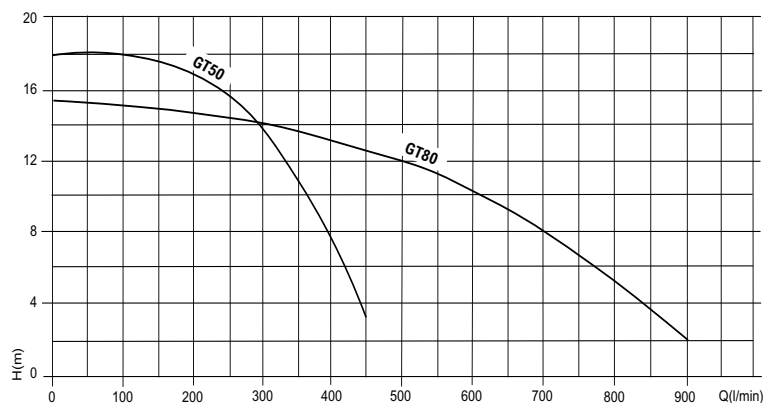

MODEL	VOLTAGE	INLET/ OUTLET	LM/HM	Kw	AMP	SOLIDS	H x W x L mm	Kg	CODE
GT50M	230v	2" x 2"	450/17	1.5	9.4	30mm	290 x 200 x 420	23	070-0050
GT50T	400v	2" x 2"	450/17	1.5	3.14	30mm	290 x 200 x 420	23	070-0070
GT80T	400v	3" x 3"	900/15	2.2	4.59	30mm	320 x 240 x 460	34	070-0090

SELF PRIMING CONTRACTOR PUMPS

BARE SHAFT UNITS COMPLETE WITH PULLEY

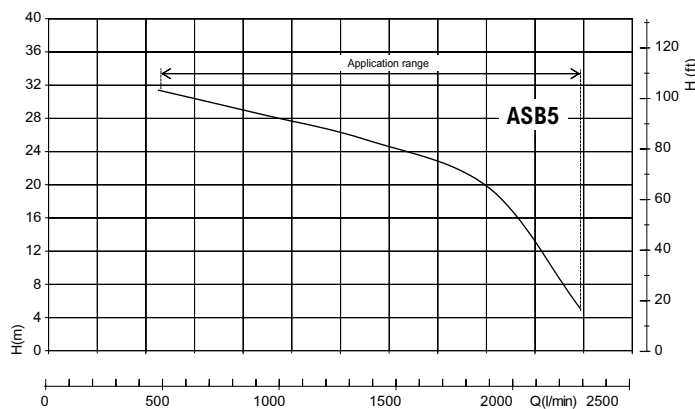
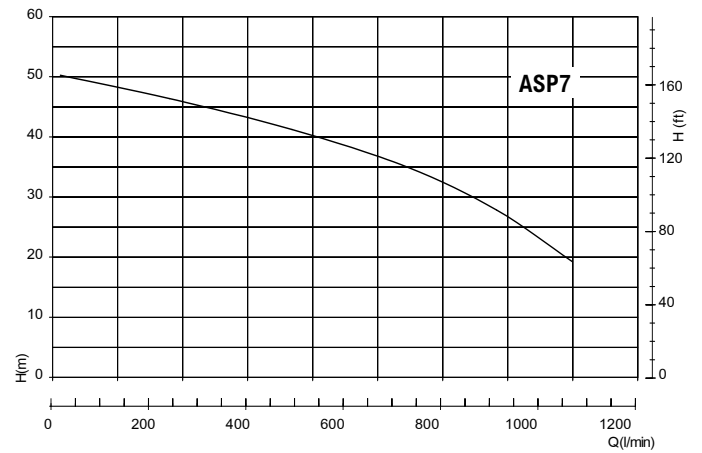
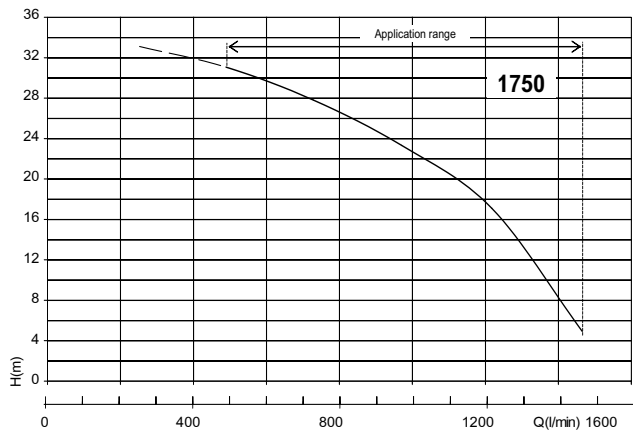
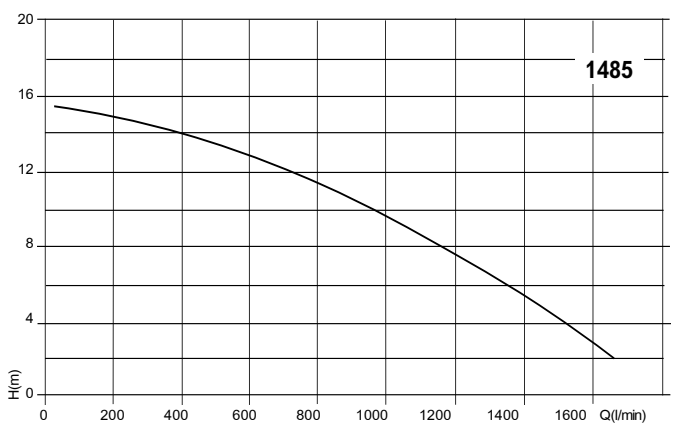
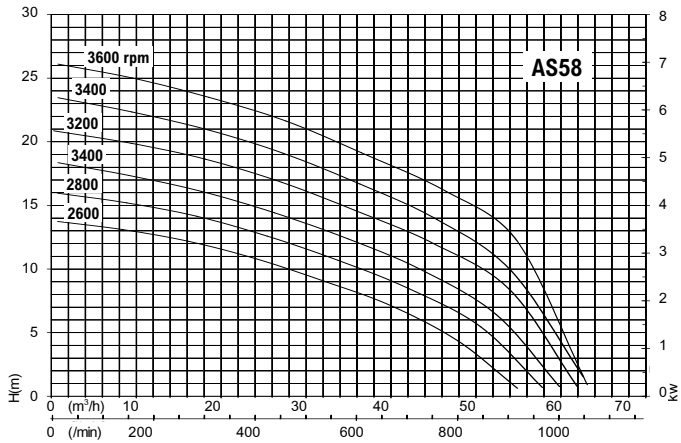
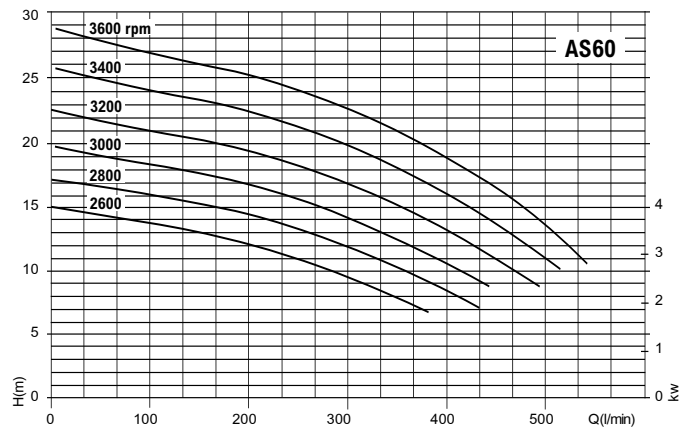
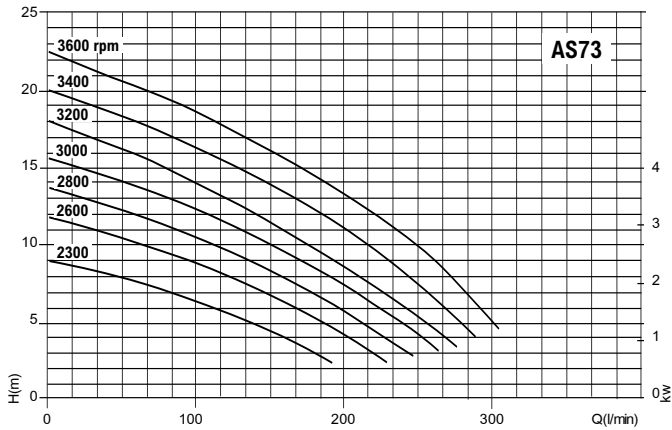

SELF PRIMING CONTRACTOR PUMPS

BARE SHAFT UNITS COMPLETE WITH PULLEY

B

Self priming pump complete with pulley. Suitable for pumping clean or slightly dirty water. Not suitable for pumping abrasives. A non-return valve is fitted on the inlet of the pump body to avoid the loss of water after the pump has stopped, making it easier to prime when the pump starts again. Maximum suction depth of 6 metres and a maximum liquid temperature of 60°C. Pump casing, inlet flange and impeller are made from cast iron. Stainless steel shaft. Carbon mechanical seal. High pressure versions, trash duty versions and bronze versions are available.

Features

Centrifugal
Bare Shaft
Self Priming

Applications

Drainage



MODEL	INLET/ OUTLET	PULLEY	LM/HM @2900 RPM	Kw	SOLIDS	H x W x L mm	Kg	CODE
B1½KQA-W AS73	1½" x 1½"	100 x 2A	275/15	0.75	6mm	300 x 183 x 250	13	070-140
B2KQA-W AS60	2" x 2"	100 x 2A	450/18	1.5	14mm	300 185 x 275	15	070-142
B3KQA-W AS58	3" x 3"	100 x 2A	900/16	2.2	25mm	300 x 185 x 295	17	070-144
B4KQA-W 1485	4" x 4"	100 x 2A	1650/15	4	35mm	405 x 315 x 485	55	070-146
B3XRA-W*	3" x 3"	100 x 2A	1450/30	7.5	24mm	400 x 280 x 450	51	070-148
G3TMKA-W ASP7*	3" x 3"	100 x 2A	1060/48	9.2	14mm	409 x 285 x 480	52	070-ASP7
B4XRA-R ASB5*	4" x 4"	100 x 2A	2050/30	15	39mm	450 x 365 x 505	65	070-ASB5

*Available upon request.

SELF PRIMING CONTRACTOR PUMPS

P.T.O. POWERED

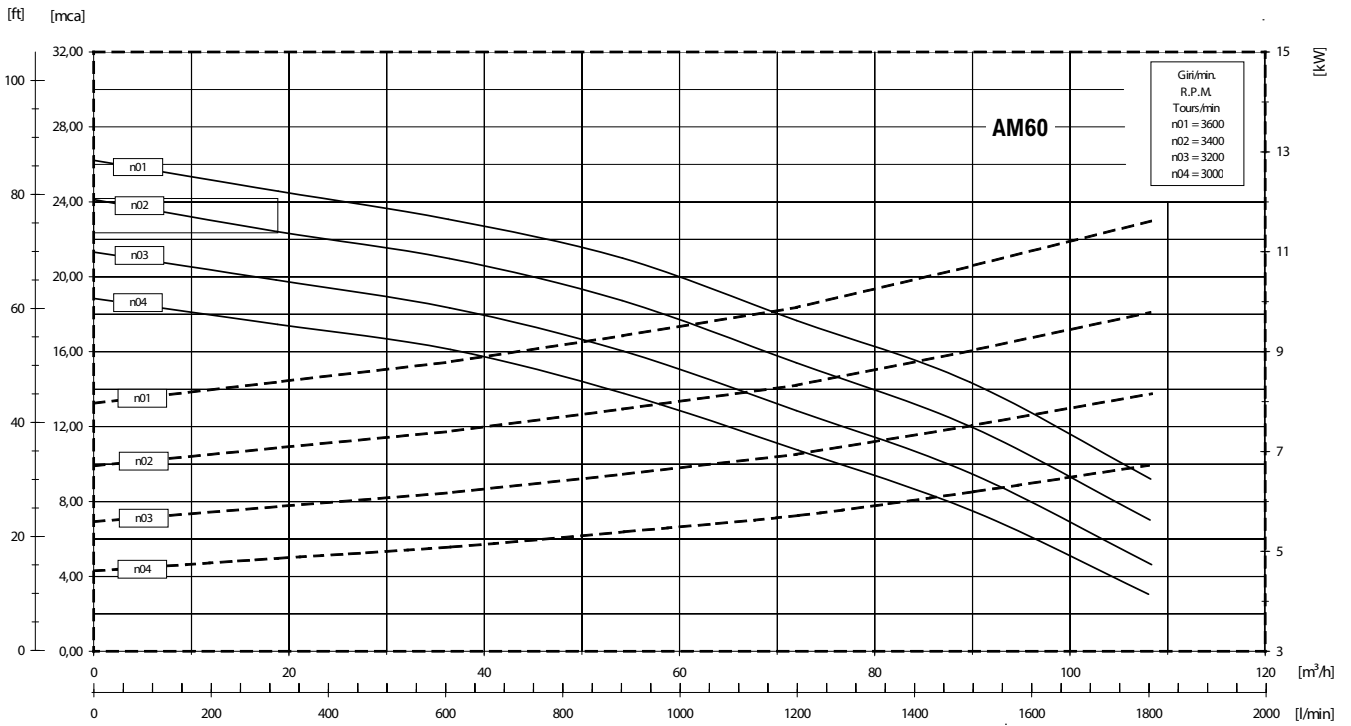
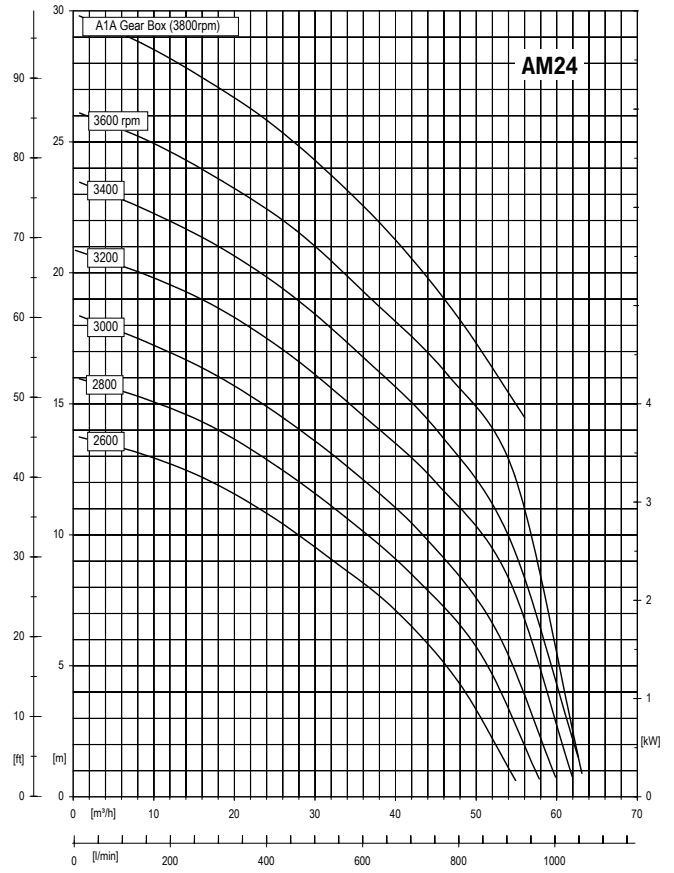
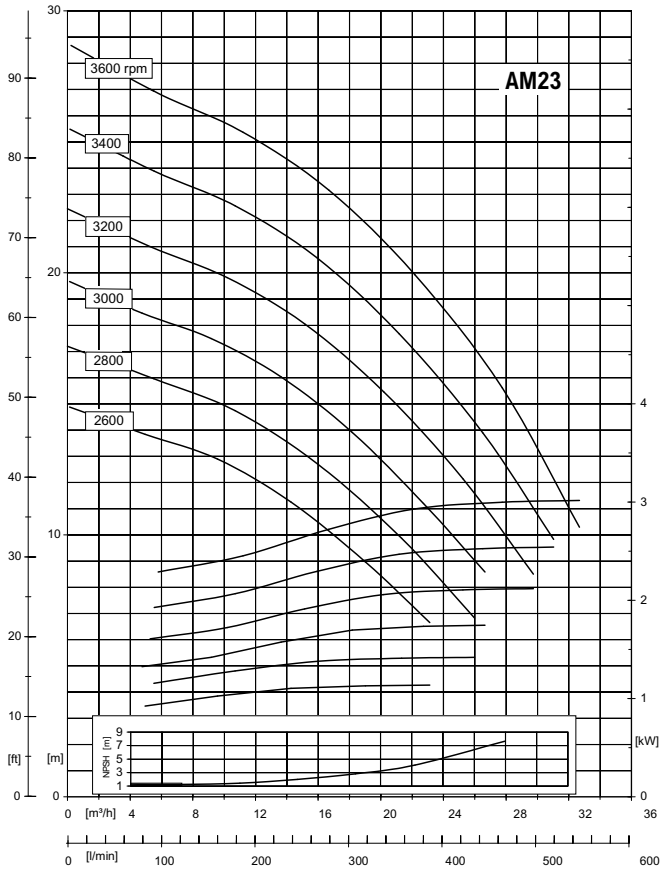

SELF PRIMING CONTRACTOR PUMPS

P.T.O. POWERED

B

Self priming pump with gearbox for connecting to tractors by a universal joint. Suitable for pumping clean or slightly dirty water. Not suitable for pumping abrasives. A non-return valve is fitted on the inlet of the pump body to avoid the loss of water after the pump has stopped, making it easier to prime when the pump starts again. Maximum suction depth of 6 metres and a maximum liquid temperature of 60°C. Pump casing, inlet flange and impeller are made from cast iron. Stainless steel shaft. Carbon mechanical seal. High pressure versions, trash duty versions and bronze versions are available upon request.

Features

Centrifugal
Bare Shaft
Self Priming

Applications

Drainage



MODEL	INLET/ OUTLET	RATIO	LM/HM	Kw	SOLIDS	H x W x L mm	Kg	CODE
B2KQ-A PTO AM23	2" x 2"	1:7,8	550/29.5@3600RPM	4	14mm	388 x 218 x 395	20	070-134
B3KQ-A PTO AM24	3" x 3"	1:7,8	1050/26@3600RPM	5.8	23mm	388 x 218 x 428	22	070-136
B4KQ-A PTO AM60	4" x 4"	1:6,9	1800/24@3600RPM	7.8	38mm	490 x 315 x 597	64	070-138

SELF PRIMING CONTRACTOR PUMPS

ELECTRIC DRIVEN CAST IRON SELF PRIMING PUMPS

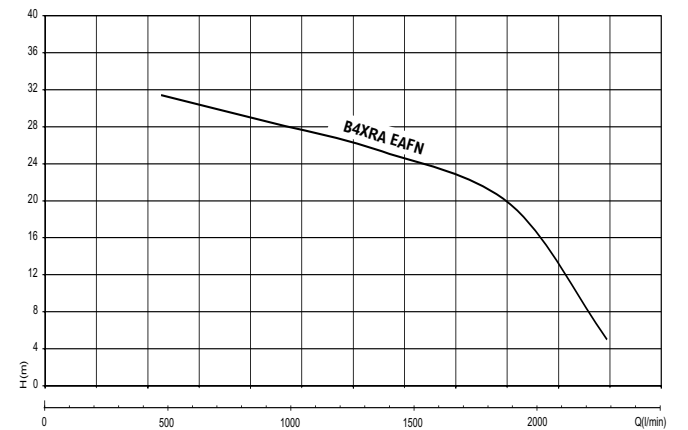
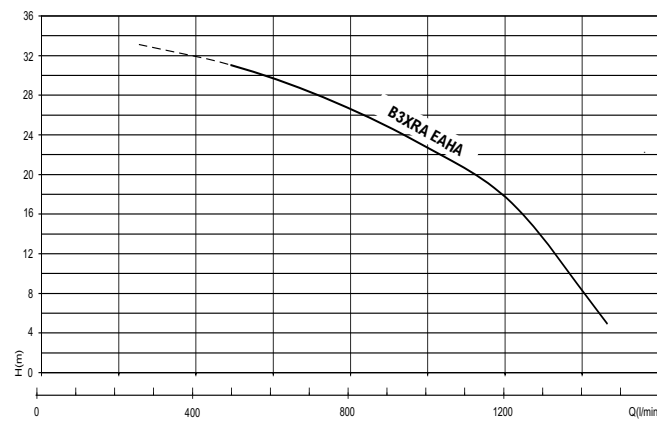
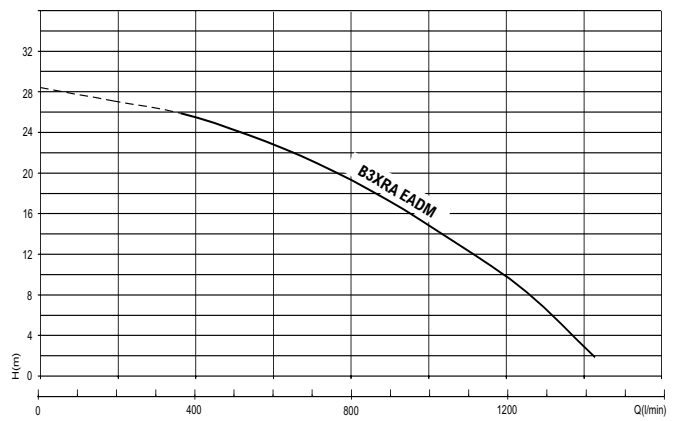
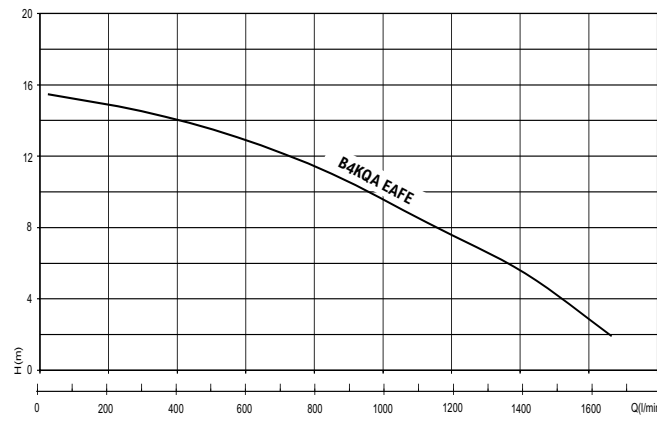
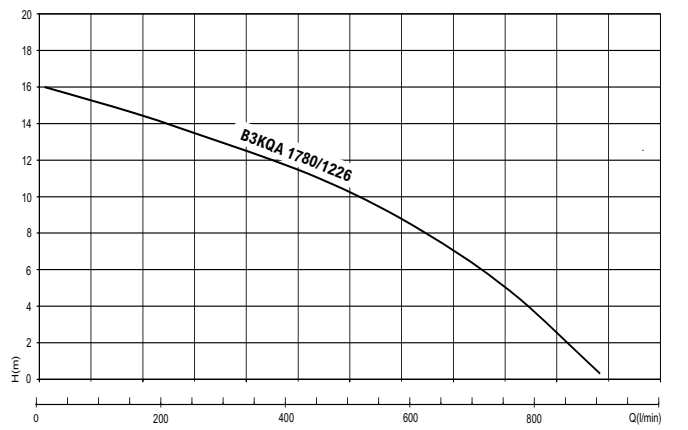
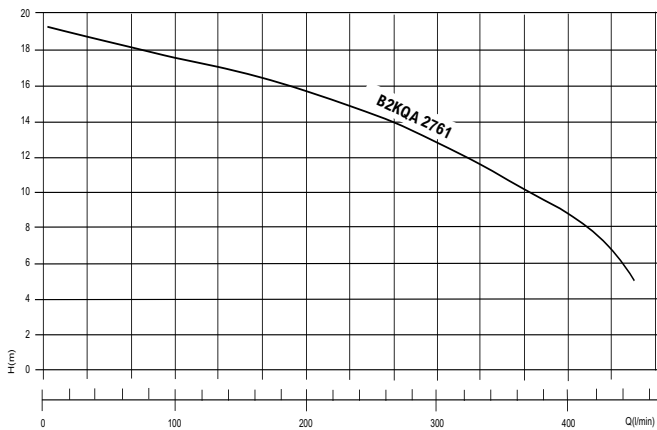
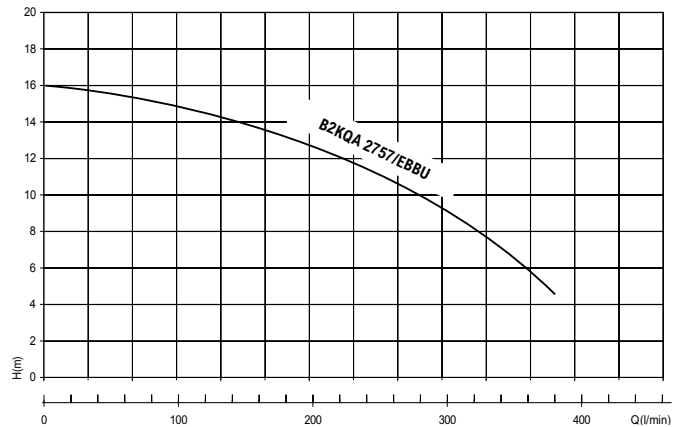
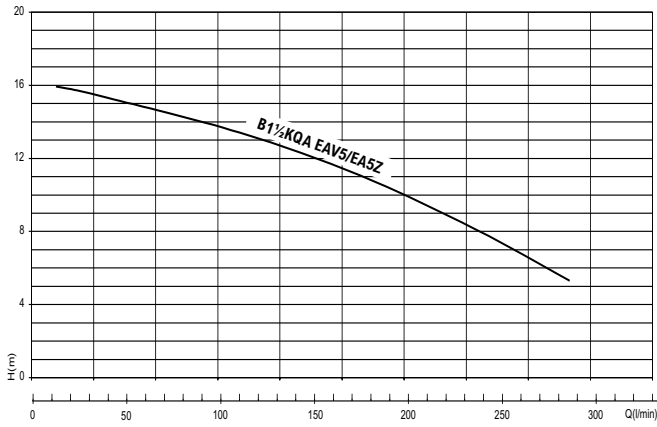

SELF PRIMING CONTRACTOR PUMPS

ELECTRIC DRIVEN CAST IRON SELF PRIMING PUMPS

B

Self priming electric pump with multi blade impeller, suitable for pumping clean or slightly dirty water. Not suitable for pumping abrasives. A non-return valve is fitted on the inlet of the pump body to avoid the loss of water after the pump has stopped, making it easier to prime when the pump starts again. Maximum suction depth of 6 metres and a maximum liquid temperature of 60°C. Pump casing, inlet flange and impeller are made from cast iron. Stainless steel shaft. Carbon mechanical seal. High pressure versions are available upon request. Models 4 Kw and above now come on a skid plate.

Features

Centrifugal
Self Priming
Cast Iron

Applications

Drainage



B2KQA shown in frame and isolator



B2KQA shown on sack trolley with isolator

MODEL	VOLTAGE	INLET/OUTLET	LM/HM	Kw	AMP	SOLIDS	H x W x L mm	Kg	CODE
B1½KQA EAV5	230v	1½" x 1½"	290/16	0.75	6.2	8mm	285 x 185 x 375	21	070-110
B2KQA 2757	230v	2" x 2"	390/16	1.1	7	12mm	300 x 185 x 410	22	070-112
B2KQA EBBU	110v	2" x 2"	390/16	1.5	19	14mm	300 x 185 x 410	22	070-114
B2KQA EBBU FR	110v	2" x 2"	390/16	1.5	19	14mm	385 x 430 x 550	28	070-114 FR
B2KQA EBBU SAC	110v	2" x 2"	390/16	1.5	19	14mm	1300 x 555 x 470	32	070-114 SAC
B3KQA 1780	230v	3" x 3"	850/15	2.2	13	27mm	300 x 185 x 485	32	070-116
B1½KQA EA5Z	400v	1½" x 1½"	290/16	0.75	1.9	8mm	285 x 185 x 375	21	070-120
B2KQA 2761	400v	2" x 2"	450/18	1.5	2.6	12mm	300 x 185 x 410	24	070-122
B3KQA 1226	400v	3" x 3"	850/15	2.2	5	27mm	300 x 185 x 485	32	070-124
B4KQA EAFE	400v	4" x 4"	1650/15	4	7.8	35mm	400 x 315 x 670	84	070-125
B3XR/A EADM	400v	3" x 3"	1400/26	5.5	11	24mm	405 x 280 x 650	96	070-126
B3XR/A EAHA	400v	3" x 3"	1450/30	7.5	14.3	24mm	405 x 280 x 650	104	070-128
B4XR/A EAFN	400v	4" x 4"	2250/30	15	26.5	39mm	455 x 365 x 800	228	070-130

SELF PRIMING CONTRACTOR PUMPS

ELECTRIC DRIVEN CAST IRON SELF PRIMING TRASH PUMPS

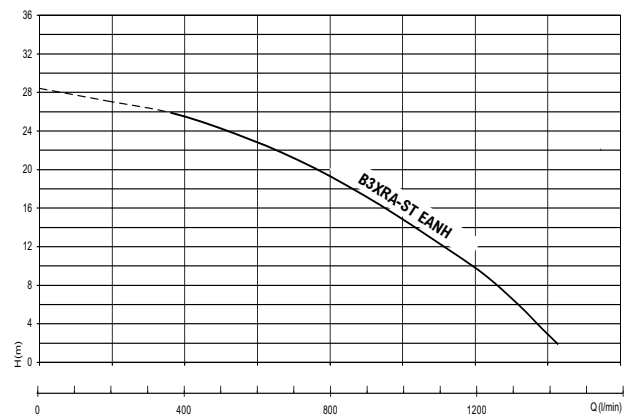
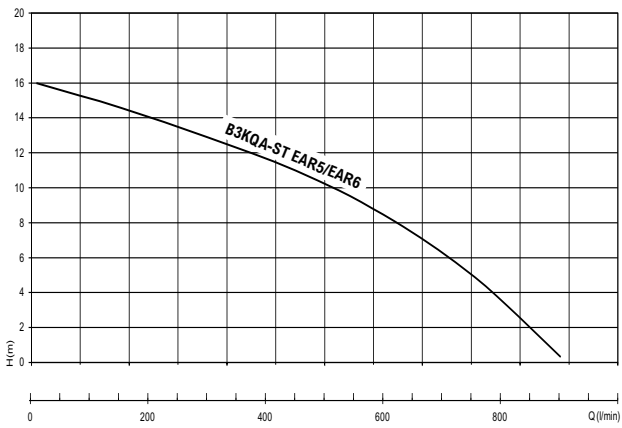
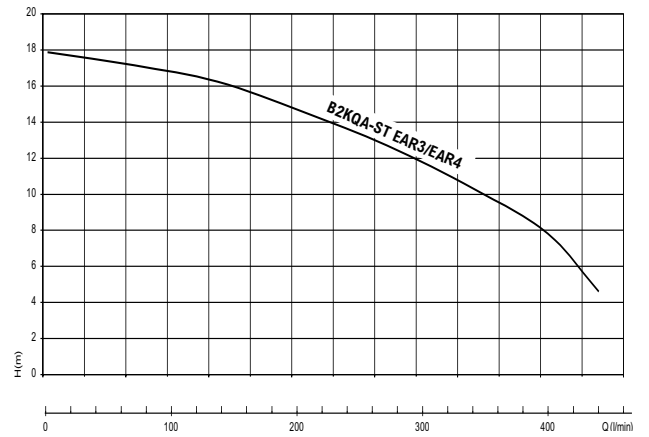
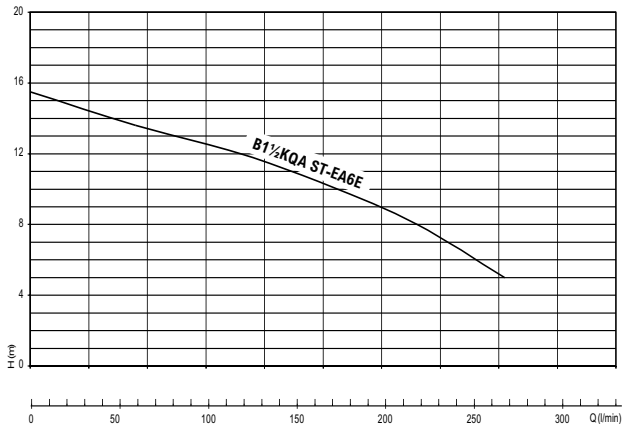

SELF PRIMING CONTRACTOR PUMPS

ELECTRIC DRIVEN CAST IRON SELF PRIMING TRASH PUMPS

B

Self priming electric pump with three blade impeller, suitable for pumping dirty water. This version is provided with an inspection door to remove any blockages that may occur, a wear disc made from stainless steel. A non-return valve is fitted on the inlet of the pump body to avoid the loss of water after the pump has stopped, making it easier to prime when the pump starts again. Maximum suction depth of 6 metres and a maximum liquid temperature of 60°C. Pump casing, inlet flange and impeller are made from cast iron. Stainless steel shaft. Silicon carbide seal. High pressure versions are available upon request.

Features

Centrifugal
Self Priming
Cast Iron

Applications

Trash Duty
Drainage



MODEL	VOLTAGE	INLET/ OUTLET	LM/HM	Kw	AMP	SOLIDS	H x W x L mm	Kg	CODE
B1½KQA-ST EA6E	230v	1½" x 1½"	280/14	0.75	6.2	11mm	285 x 185 x 375	12	070-001
B2KQA-ST EAR3	230v	2" x 2"	440/17	1.5	9	19mm	300 x 185 x 375	25	070-002
B3KQA-ST EAR5	230v	3" x 3"	850/15	2.2	13	27mm	300 x 185 x 445	32	070-003
B1½KQA-ST EA6F	400v	1½" x 1½"	280/14	0.75	1.9	11mm	285 x 185 x 375	12	070-000
B2KQA-ST EAR4	400v	2" x 2"	440/17	1.5	4	11mm	300 x 185 x 375	25	070-004
B3KQA-ST EAR6	400v	3" x 3"	850/15	2.2	5	27mm	300 x 185 x 445	32	070-005
B3XRA-ST EANH	400v	3" x 3"	1400/26	5.5	11	24mm	470 x 360 x 800	98	070-008

SELF PRIMING CONTRACTOR PUMPS

ELECTRIC DRIVEN S/STEEL & BRONZE SELF PRIMING PUMPS

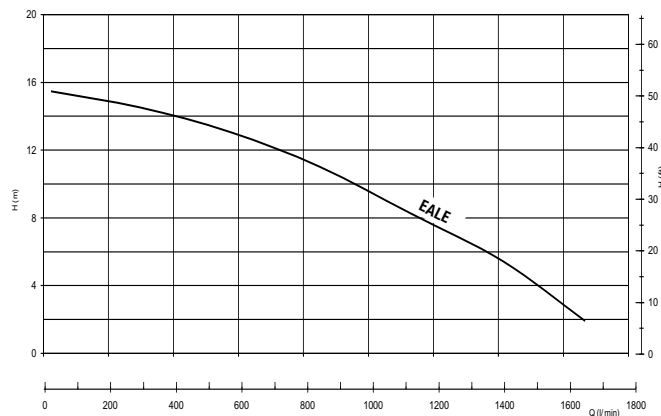
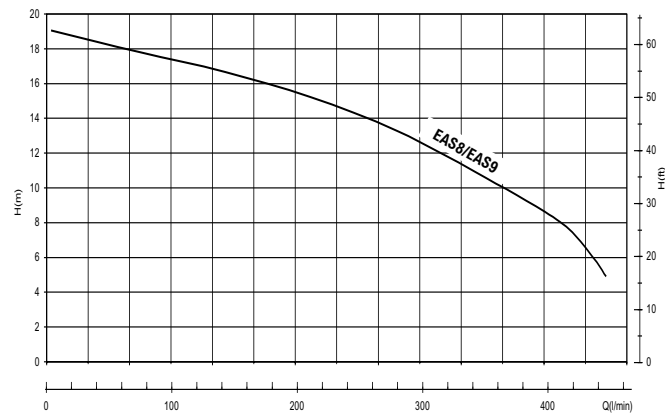
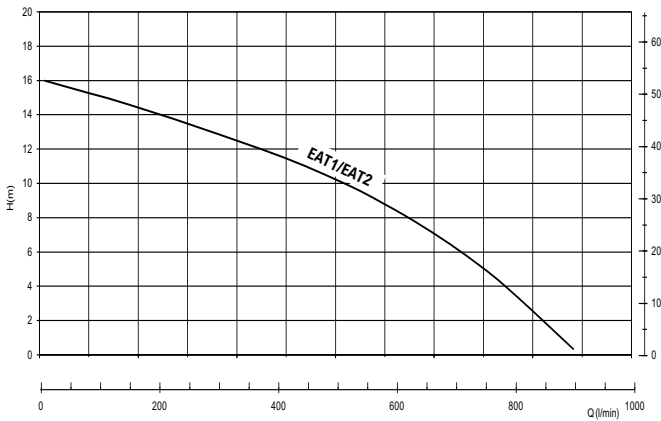
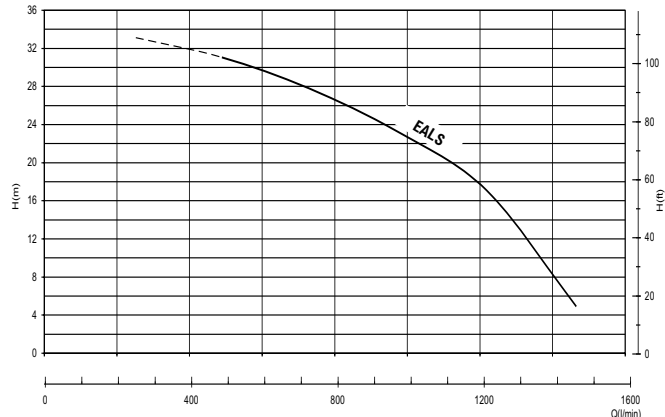
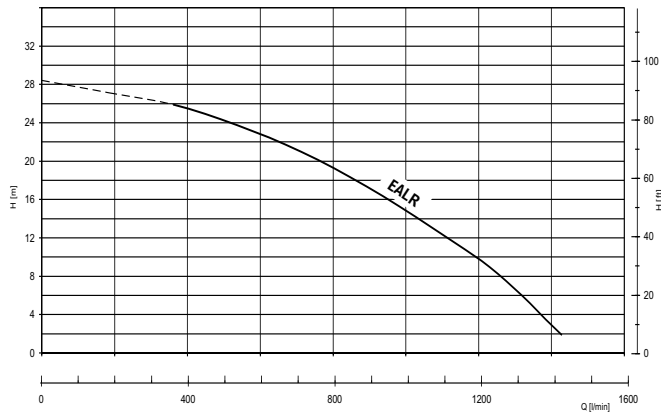
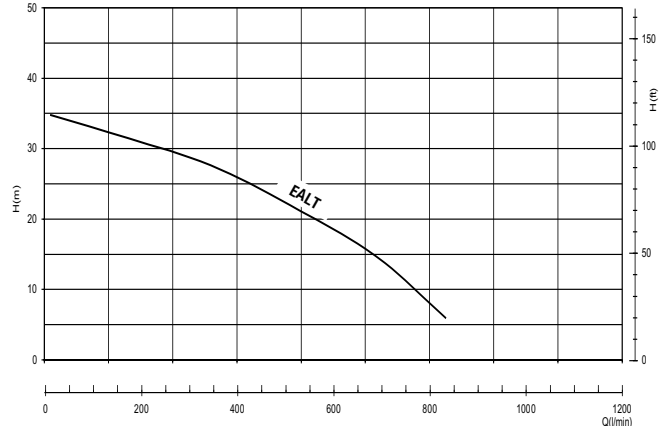
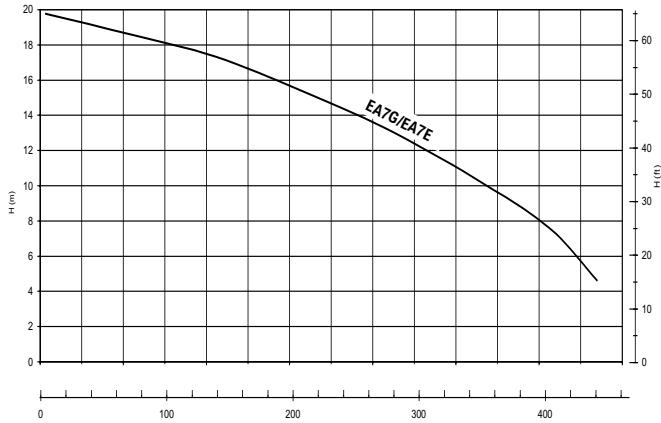

SELF PRIMING CONTRACTOR PUMPS

ELECTRIC DRIVEN S/STEEL & BRONZE SELF PRIMING PUMPS

B

Self priming electric pumps in stainless steel or bronze. A non-return valve is fitted on the inlet of the pump body to avoid the loss of water after the pump has stopped, making it easier to prime when the pump starts again. Maximum suction depth of 6 metres and a maximum liquid temperature of 60°C. Stainless steel model suitable for pumping acidic waters, transferring dilute acid, fruit juice or fluid food stuff. Pump casing, inlet flange and impeller and shaft are made from stainless steel. Silicon carbide seal. Bronze model suitable for pumping sea water and the circulation of swimming pools. Pump casing, inlet flange and impeller are made from bronze. Stainless steel shaft, carbon mechanical seal.

Features

Centrifugal
Self Priming
S/Steel or Bronze Pump

Applications

S/Steel for Acidic Water
Bronze for Sea Water



MODEL	VOLTAGE	INLET/ OUTLET	LM/HM	Kw	AMP	SOLIDS	H x W x L mm	Kg	CODE
B2KQA-A/X M EA7G* S/STEEL	230v	2" x 2"	440/18	1.5	9	16mm	300 x 185 x 410	24	070-EA7G
B2KQA-A/X T EA7E* S/STEEL	400v	2" x 2"	440/18	1.5	4	16mm	300 x 185 x 410	24	070-EA7E
G3TMK-A/X T EALT* S/STEEL	400v	3" x 3"	850/35	4	7.8	8mm	400 x 280 x 635	83	070-EALT
B3XR-A/X T EALR* S/STEEL	400v	3" x 3"	1400/26	5.5	11	24mm	405 x 280 x 650	96	070-EALR
B3XR-A/X T EALS* S/STEEL	400v	3" x 3"	1450/30	7.5	14.3	24mm	405 x 280 x 650	98.5	070-EALS
B2KQ-A/B M EAS8 BRONZE	230v	2" x 2"	450/18	1.5	9	16mm	300 x 185 x 410	26.5	070-020
B3KQ-A/B M EAT1 BRONZE	230v	3" x 3"	900/16	2.2	13	27mm	300 x 185 x 410	33	070-022
B2KQ-A/B T EAS9 BRONZE	400v	2" x 2"	450/18	1.5	4	16mm	300 x 185 x 410	26.5	070-024
B3KQ-A/B T EAT2* BRONZE	400v	3" x 3"	900/16	2.2	5	27mm	300 x 185 x 445	33	070-026
B4KQ-A/B T EALE* BRONZE	400v	4" x 4"	1650/15	4	7.8	35mm	405 x 315 x 670	87	070-EALE

*Available upon request.

SELF PRIMING CONTRACTOR PUMPS

CAST IRON SELF PRIMING PUMPS HIGH HEAD

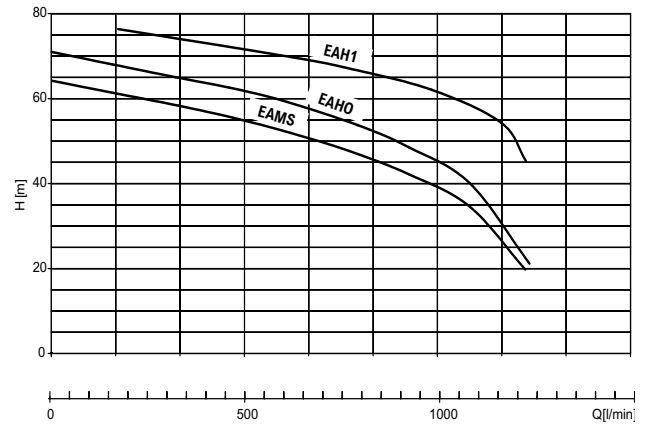
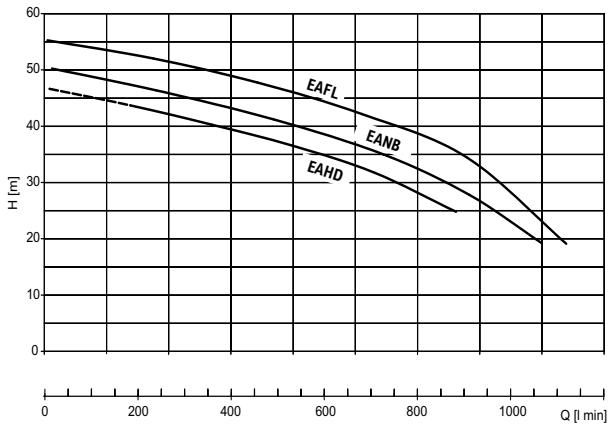
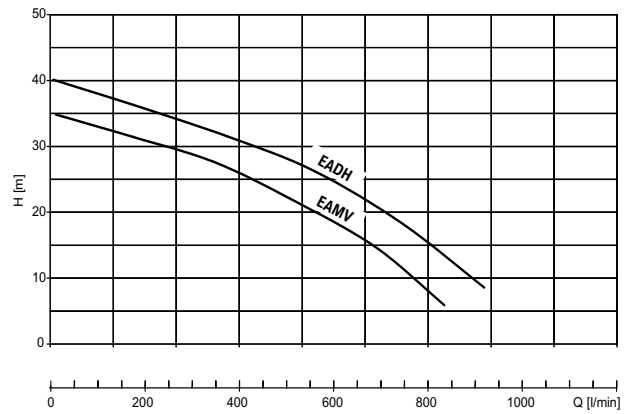
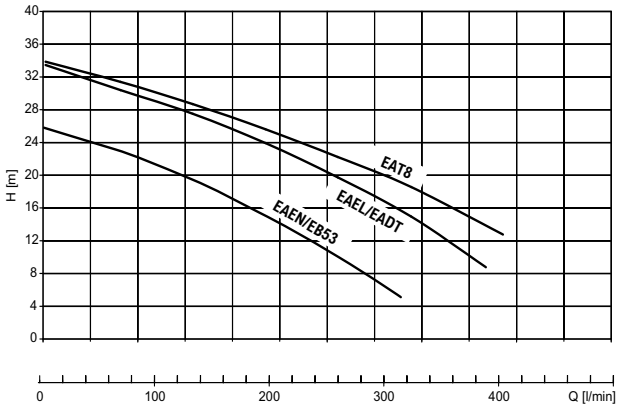

SELF PRIMING CONTRACTOR PUMPS

CAST IRON SELF PRIMING PUMPS HIGH HEAD

B

Self-priming pump with open impeller suitable for pumping clean or slightly dirty water with no abrasives. A non-return valve is fitted on the inlet of the pump to avoid the loss of water after the pump has stopped, making it easier to prime when the pump starts again. Maximum suction depth of 6 metres and a maximum liquid temperature of 70°C. Stainless steel shaft, carbon mechanical seal. Models 4Kw and above come assembled on a skid plate.

Features

Centrifugal
Self Priming
High Head

Applications

Clean Water
Dirty Water



MODEL	VOLTAGE	INLET/ OUTLET	LM/HM	Kw	AMP	SOLIDS	H x W x L mm	Kg	CODE
G2TMK-A EAEN	230v	2" x 2"	315/25	1.5	10.5	5mm	300 x 185 x 410	35	070-EAEN
G2TMK-A EB53	400v	2" x 2"	315/25	1.5	4	5mm	300 x 185 x 410	35	070-EB53
G2TMK-A EAEL	230v	2" x 2"	370/33	2.2	13	6mm	316 x 230 x 450	37	070-EAEL
G2TMK-A EADT	400v	2" x 2"	370/33	2.2	6	6mm	316 x 230 x 450	37	070-EADT
G2TMK-A EAT8	400v	2" x 2"	400/33	3	7	8mm	285 x 220 x 375	37	070-EAT8
G3TMK-A EAMV*	400/690v	3" x 3"	850/35	4	7.8	8mm	450 x 360 x 700	83	070-EAMV
G3TMK-A EADH*	400/690v	3" x 3"	900/38	5.5	10.5	10mm	470 x 360 x 800	99	070-EADH
G3TMK-A EAHD*	400/690v	3" x 3"	900/44	7.5	14.1	13mm	470 x 360 x 800	105	070-EAHD
G3TMK-A EANB*	400/690v	3" x 3"	1060/48	9.2	17.2	14mm	470 x 360 x 800	113	070-EANB
G3TMK-A EAFL*	400/690v	3" x 3"	1060/52	11	19.5	16mm	506 x 470 x 1000	202	070-EAFL
B3ZPM-A EAMS*	400/690v	3" x 3"	1200/60	15	28.8	13mm	530 x 470 x 1000	210	070-EAMS
B3ZPM-A EAHO*	400/690v	3" x 3"	1250/65	18.5	33	14mm	530 x 470 x 1000	247	070-EAHO
B3ZPM-A EAH1*	400/690v	3" x 3"	1250/75	22	38.8	19mm	530 x 470 x 1000	275	070-EAH1

*Available upon request.

SELF PRIMING CONTRACTOR PUMPS

FUEL OIL 'RED' HIGH VOLUME DIESEL TRANSFER

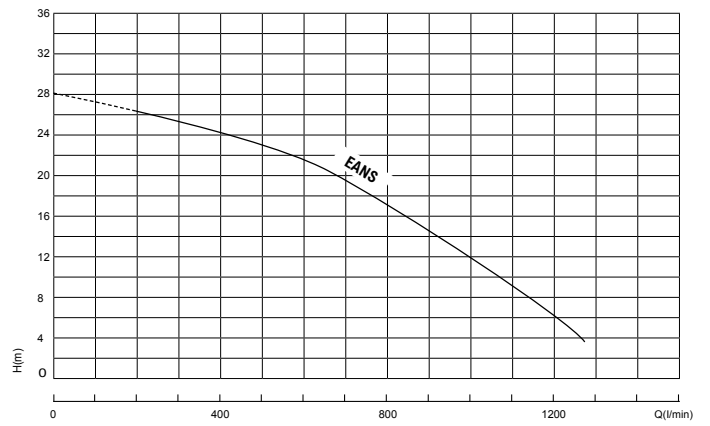
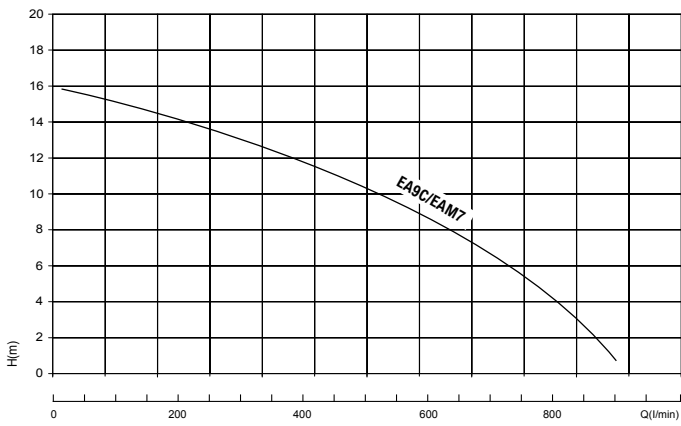
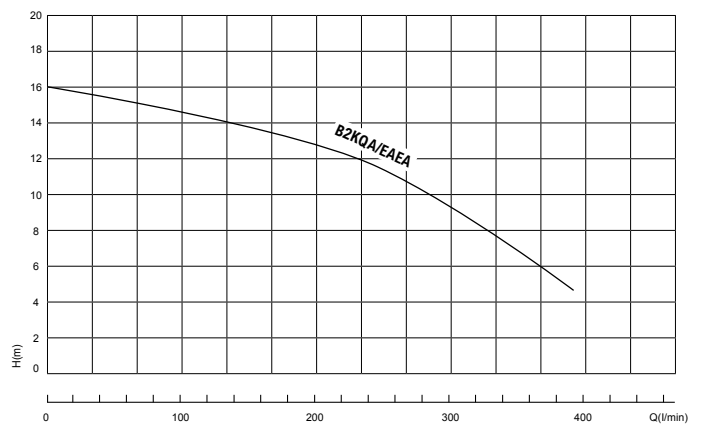
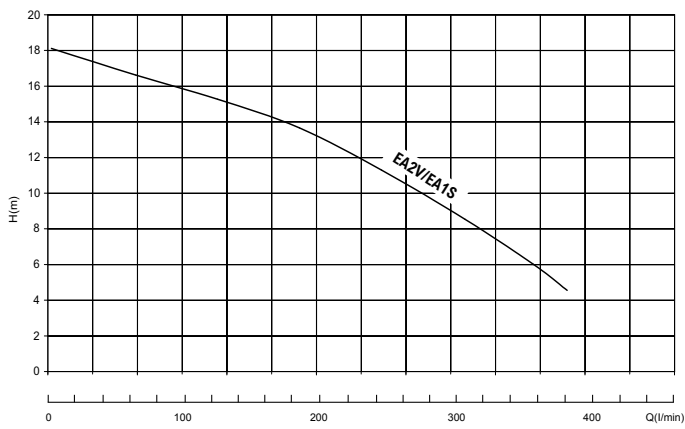
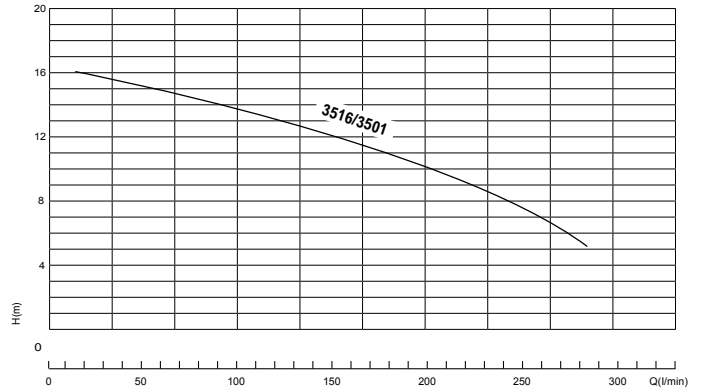
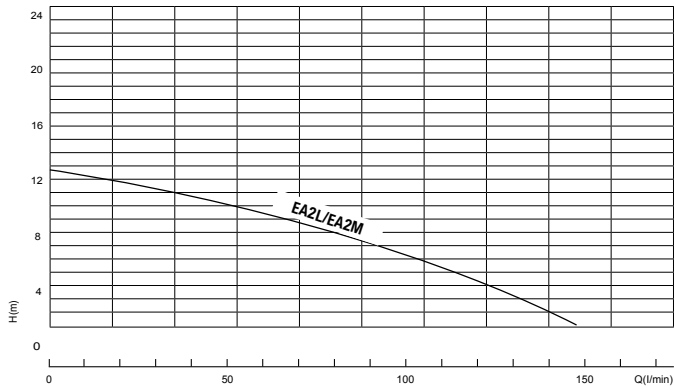

SELF PRIMING CONTRACTOR PUMPS

FUEL OIL 'RED' HIGH VOLUME DIESEL TRANSFER

B

Self priming electric pump with open impeller to transfer fuels. Suitable for pumping diesel, gas oil, paraffin. NOT FOR PUMPING PETROL. A non-return valve is fitted on the inlet of the pump body to avoid the loss of liquid after the pump has stopped, making it easier to prime when the pump starts again. Maximum suction depth of 6 metres and a maximum liquid temperature of 60°C. Pump casing, inlet flange and impeller are made from cast iron. Stainless steel shaft. Viton mechanical seal and Viton check valve.

Features

Centrifugal
Self Priming

Applications

Diesel Transfer



MODEL	VOLTAGE	INLET/ OUTLET	LM/HM	Kw	AMP	SOLIDS mm	H x W x L mm	Kg	CODE
B1KQ-A RED EA2L	230v	1" x 1"	140/12	0.55	4.1	7	285 x 216 x 375	15	070-168
B1½KQ-A RED 3516	230v	1½" x 1½"	290/16	0.75	6.2	8	300 x 180 x 375	20	070-3516
B2KQ-A RED EA2V	230v	2" x 2"	450/18	1.5	9	12	300 x 185 x 410	21	070-166
B2KQ-A RED EAEA	110v	2" x 2"	390/16	1.5	19	14	300 x 185 x 410	25	070-159
B3KQ-A RED EA9C	230v	3" x 3"	850/15	2.2	13	27	300 x 185 x 445	30	070-EA9C
B1KQ-A RED EA2M	400v	1" x 1"	140/12	0.55	1.8	7	285 x 216 x 375	15	070-169
B1½KQ-A RED 3501	400v	1½" x 1½"	290/16	0.75	1.9	8	300 x 180 x 375	20	070-163
B2KQ-A RED EA1S	400v	2" x 2"	450/18	1.5	2.6	12	300 x 185 x 410	21	070-167
B3KQ-A RED EAM7	400v	3" x 3"	850/15	2.2	5	27	300 x 185 x 445	30	070-165
B3XR-A RED EANS	400v	3" x 3"	1200/26	4	7.8	35	400 x 280 x 635	74	070-EANS

SELF PRIMING CONTRACTOR PUMPS

FUEL OIL 'RED' COMPLETE WITH ATEX MOTOR

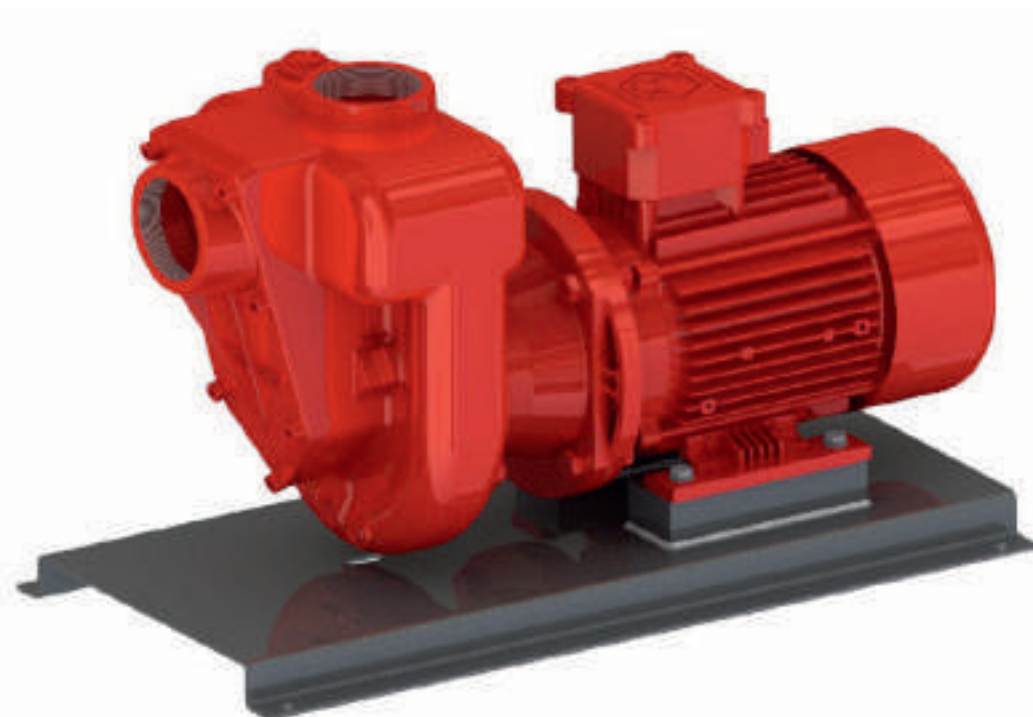
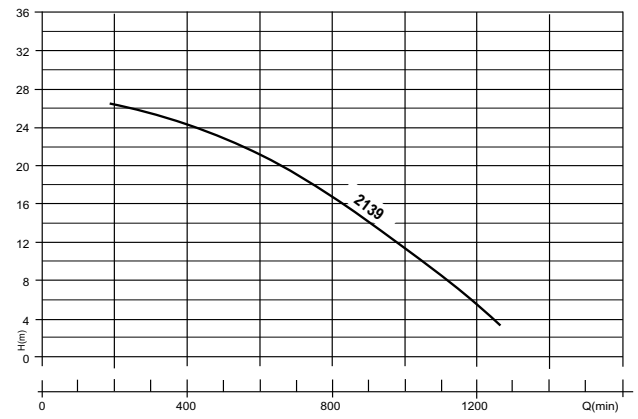
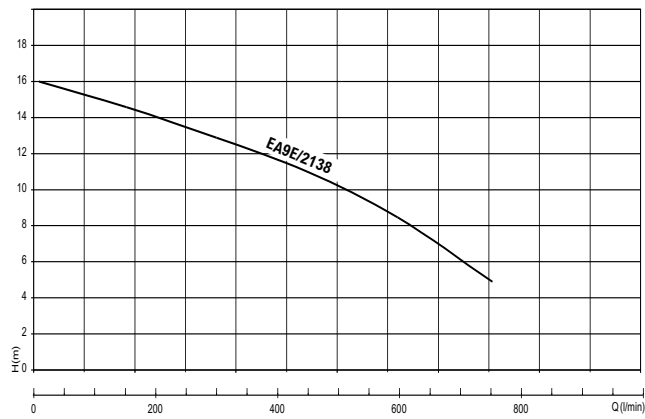
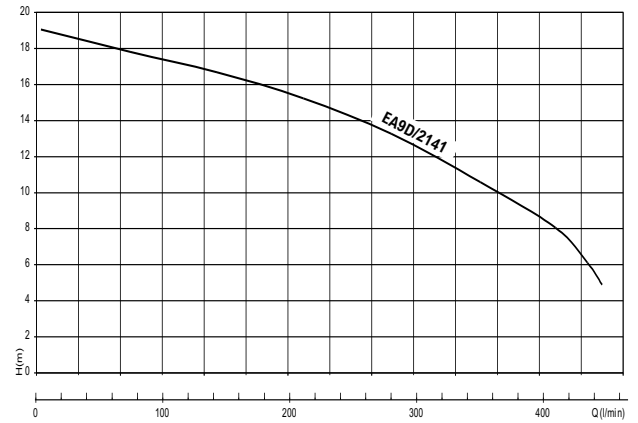
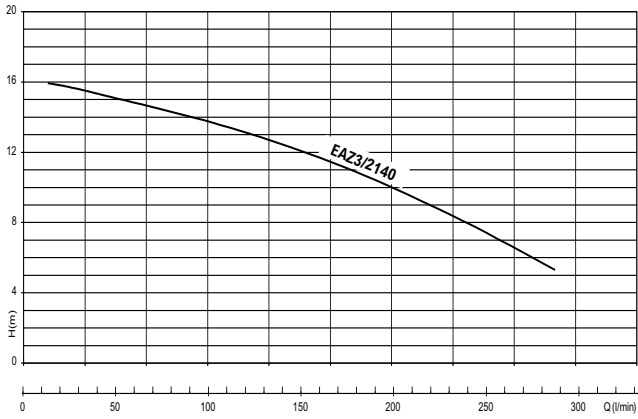

SELF PRIMING CONTRACTOR PUMPS

FUEL OIL 'RED' COMPLETE WITH ATEX MOTOR

B

Self priming electric pump with flame proof motor for the transfer of fuels. Open impeller suitable for pumping diesel, gas oil, paraffin. NOT FOR PUMPING PETROL. A non-return valve is fitted on the inlet of the pump body to avoid the loss of liquid after the pump has stopped, making it easier to prime when the pump starts again. Maximum suction depth of 6 metres and a maximum liquid temperature of 60°C. Pump casing, inlet flange and impeller are made from cast iron. Stainless steel shaft. Viton mechanical seal and Viton check valve. Manufactured in accordance with standards ATEX 94/9/CE. (II 2G Ex d IIC T4)

Features

Centrifugal
Self Priming
Atex

Applications

Diesel Transfer



ATEX 94/9/CE
II 2G EX d IIC T4

MODEL	VOLTAGE	INLET/ OUTLET	LM/HM	Kw	AMP	SOLIDS	H x W x L mm	Kg	CODE
B1½KQA RED EAZ3*	230v	1½" x 1½"	290/16	0.75	4.8	8mm	300 x 255 x 495	16	070-EAZ3
B2KQA RED EA9D*	230v	2" x 2"	450/18	1.5	9.1	16mm	300 x 280 x 520	27	070-EA9D
B3KQA RED EA9E*	230v	3" x 3"	850/15	2.2	13.1	27mm	300 x 280 x 550	50	070-EA9E
B1½KQA RED 2140*	400v	1½" x 1½"	290/16	0.75	1.8	8mm	300 x 255 x 495	40	070-2140
B2KQA RED 2141*	400v	2" x 2"	450/18	1.5	4.5	16mm	300 x 280 x 520	27	070-2141
B3KQA RED 2138*	400v	3" x 3"	850/15	2.2	4.8	27mm	300 x 280 x 550	50	070-2138
B3XR-A RED 2139*	400v	3" x 3"	1200/26	4	7.8	19mm	400 x 335 x 685	112	070-2139

*Available upon request.

SURFACE MOUNTED PUMPS

PERIPHERAL TURBINE PUMPS

E

These peripheral turbine pumps are made to develop high pressure and limited flow rates. PM/T45BR and PB100 have brass impellers and brass pump bodies. The QB60/80 and PM/T90 have brass impellers and cast iron pump bodies. PXC have ryton impellers and stainless steel pump bodies. Clean water only and mainly used for water pressure boosting of small scale booster systems and washing systems.

Features

Peripheral Turbine
High Pressure

Applications

Water Boosting
Small Industrial

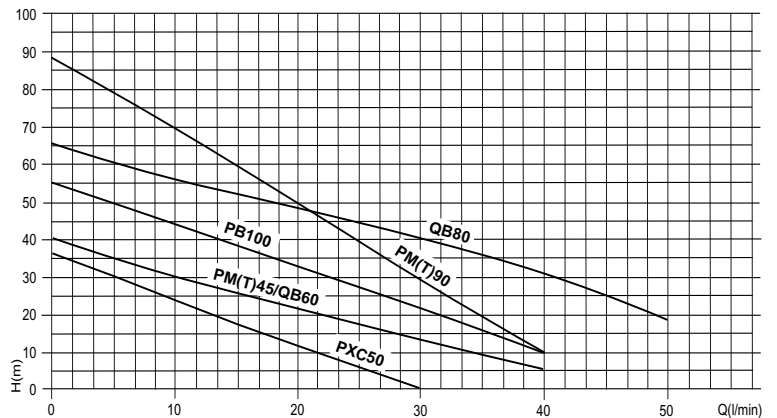

QB60



PXC



PM/T 90



PB100



PM(T) 45 BR

MODEL	VOLTAGE	INLET/ OUTLET	LM/HM	Kw	AMP	H x W x L mm	Kg	CODE
QB60	230v	1" x 1"	35/35	0.37	2.5	151 x 118 x 265	5.5	9000-2060
QB80	230v	1" x 1"	60/65	0.75	5.0	157 x 134 x 305	10.5	9000-2080
PM45 BR	230v	1" x 1"	40/40	0.37	2.3	155 x 125 x 265	6.2	022-020
PM45 BR	110v	1" x 1"	40/40	0.37	4.6	155 x 125 x 265	6.2	022-023
PMT45 BR	400v	1" x 1"	40/40	0.37	1	155 x 125 x 265	6.2	022-024
PB100	230v	1" x 1"	40/55	1.0	3.8	169 x 155 x 273	8.2	022-040
PB100	400v	1" x 1"	40/55	1.0	2.6	169 x 155 x 273	8.2	022-044
PM90	230v	1" x 1"	40/88	0.74	5.6	172 x 150 x 286	10.5	022-050
PMT90	400v	1" x 1"	40/88	0.74	2	172 x 150 x 286	10.5	022-052
PXC50	230v	1" x 1"	30/36	0.38	2.6	160 x 124 x 255	5.0	9000-2040
PXC50	400v	1" x 1"	30/36	0.38	2.2	160 x 124 x 255	5.0	9000-2045

SURFACE MOUNTED PUMPS

CENTRIFUGAL PUMPS

E

CM High flow, low pressure pumps, clean water use with no abrasives. The CM 50 has a technopolymer impeller and the CM 100-61 has a brass impeller. CR High flow, low pressure pumps centrifugal brass open impeller capable of handling up to 10mm soft solids. Cast iron pump body and carbon mechanical seal.

Features

High Flow
Low Pressure

Applications

Water Boosting
Washing Systems



CM



CR

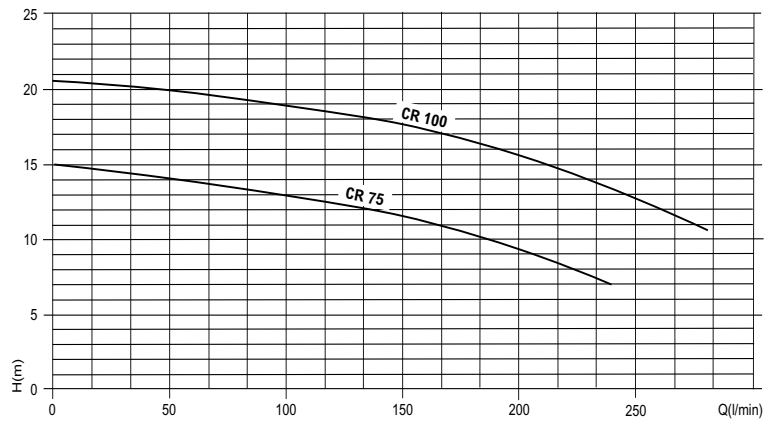
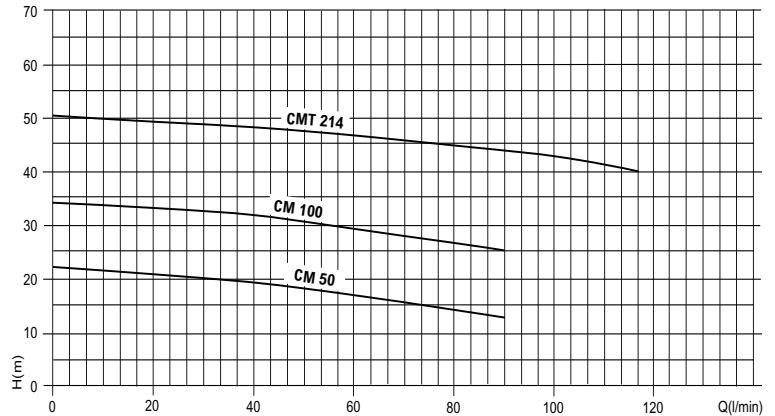

MODEL	VOLTAGE	INLET/OUTLET	LM/HM	Kw	AMP	H x W x L mm	Kg	CODE
CM 50	230v	1" x 1"	90/22	0.37	2.8	202 x 160 x 265	9	022-110
CM 100/61	230v	1" x 1"	90/33	0.74	5.7	234 x 185 x 300	14	022-120
CMT 214	400v	1¼" x 1"	120/50	1.5	4.9	285 x 225 x 348	23	022-140
CR 75	230v	1½" x 1¼"	250/15	0.59	3.4	222 x 170 x 308	13	022-316
CR 100	230v	1½" x 1¼"	280/21	0.74	5.3	222 x 170 x 308	14	022-320
CRT 100	400v	1½" x 1¼"	280/21	0.74	2.4	222 x 170 x 308	14	022-322

SURFACE MOUNTED PUMPS

PENTAX CAM JET SELF PRIMING CENTRIFUGAL PUMPS

E

Jet cast iron self priming centrifugal pumps used for water supplies, washing systems and garden irrigation. Cast iron pump bodies and motor brackets. Noryl impeller. Diffuser and venturi system made from technopolymer. Clean water only with a maximum liquid temperature of 50°C. Maximum suction height of 7 metres with footvalve

Features

High Pressure
Self Priming

Applications

Water Boosting
Washing Systems
Booster Sets



CAM 100



CAM 150-300

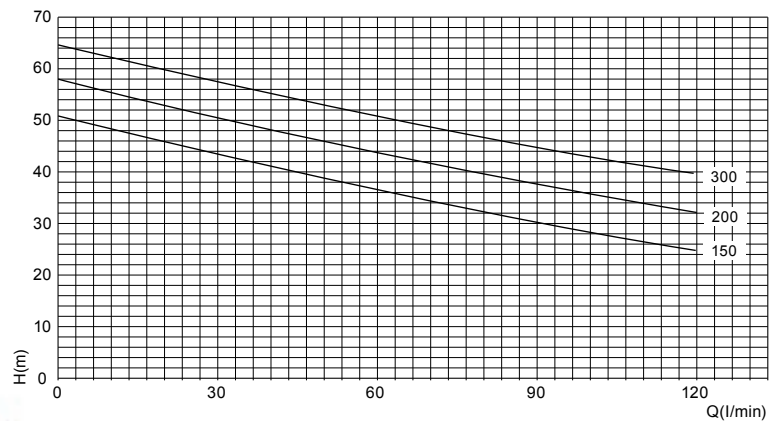
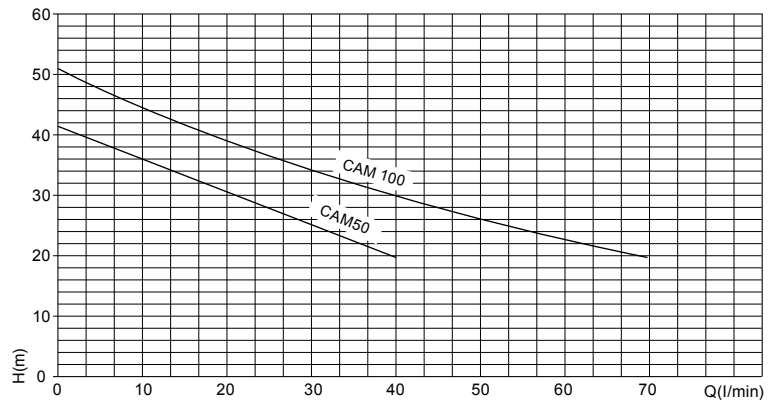

MODEL	VOLT	INLET / OUTLET	LM/HM	Kw	AMP	H x W x L mm	Kg	CODE
CAM 50	230v	1" x 1"	40/40	0.44	3.2	195 x 180 x 420	15.4	1000-0125
CAM 100N	230v	1" x 1"	60/52	0.74	4.7	195 x 180 x 420	16	1000-0235
CAM 100N	110v	1" x 1"	70/51	0.74	9.4	195 x 180 x 410	16	022-282
CAM 150	230v	1½" x 1¼"	120/50	1.1	8.2	232 x 203 x 506	24.5	1000-0145
CAM 200	230v	1½" x 1¼"	120/58	1.5	9.8	232 x 203 x 506	25.5	1000-0155
CAMT 50	400v	1½" x 1"	40/40	0.44	1.2	195 x 180 x 420	15.4	1000-0130
CAMT 100N	400v	1" x 1"	60/52	0.74	2.3	195 x 180 x 410	16	1000-0140
CAMT 150	400v	1½" x 1¼"	120/50	1.1	3.4	232 x 203 x 506	24.5	1000-0180
CAMT 200	400v	1½" x 1¼"	120/58	1.5	3.9	232 x 203 x 506	25.5	1000-0190
CAMT 300	400v	1½" x 1¼"	120/64	2.2	4.8	232 x 203 x 506	26.5	1000-0200

SURFACE MOUNTED PUMPS

PENTAX CAB JET SELF PRIMING CENTRIFUGAL PUMPS

E

Jet cast iron self priming centrifugal pumps used for water supplies, washing systems and garden irrigation. Cast iron pump bodies and motor brackets. Noryl impeller. Diffuser and venturi system made from technopolymer. Clean water only with a maximum liquid temperature of 50°C. Maximum suction height of 7 metres with footvalve. When connected up to pressure accumulator tanks and pressure switches these can be set up to run automatically

Features

High Pressure
Self Priming

Applications

Water Boosting
Washing Systems
Booster Sets

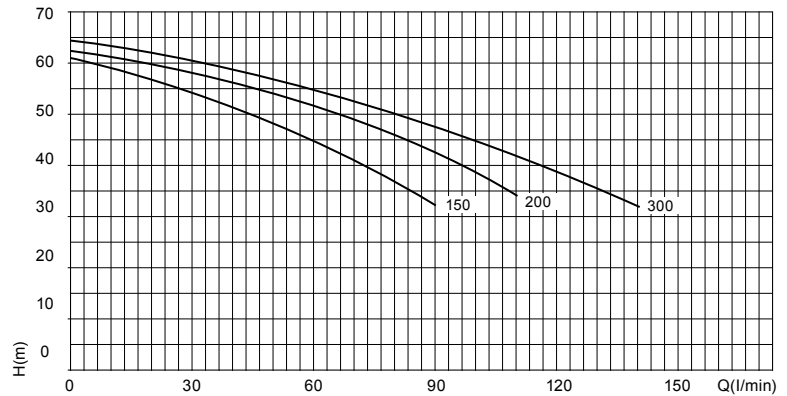

MODEL	VOLT	INLET / OUTLET	LM/HM	Kw	AMP	H x W x L mm	Kg	CODE
CAB 150	230v	1½" x 1"	90/61	1.1	7.9	240 x 220 x 596	27.9	1000-0175
CAB 200	230v	1½" x 1"	110/62	1.5	10.3	240 x 220 x 596	28.7	1000-0185
CAB 300	230v	1½" x 1"	140/64	2.2	11.8	240 x 220 x 596	29.6	1000-0195
CABT 150	400v	1½" x 1"	90/61	1.1	3.3	240 x 220 x 596	27.9	1000-0180
CABT 200	400v	1½" x 1"	110/62	1.5	3.9	240 x 220 x 596	28.7	1000-0190
CABT 300	400v	1½" x 1"	140/64	2.2	4.9	240 x 220 x 596	29.6	1000-0200

SURFACE MOUNTED PUMPS

PENTAIR JET SELF PRIMING CAST IRON CENTRIFUGAL PUMPS

E

Jet traditional cast iron self priming pumps mainly used for water boosting systems, washing systems and garden irrigation. Cast iron pump bodies and motor brackets. Impeller, diffuser and venturi system made from technopolymer. Jet 100-68/80 impeller made from brass. Clean water only with a maximum liquid temperature of 50°C. Maximum suction height of 7 metres with footvalve.

Features

High Pressure
Self Priming

Applications

Water Boosting
Washing Systems
Booster Sets

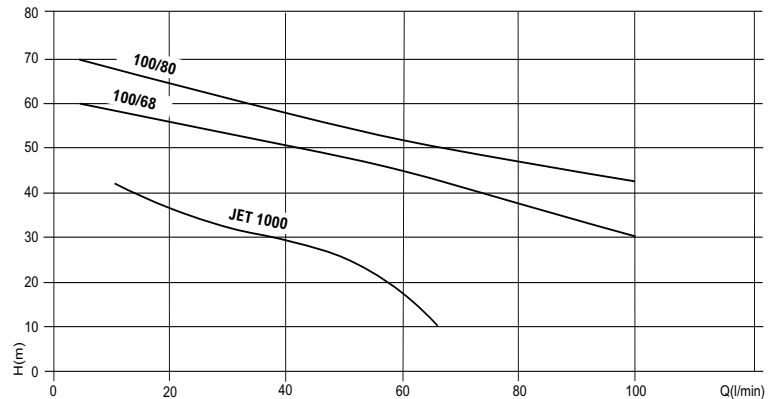

MODEL	VOLTAGE	INLET/ OUTLET	LM/HM	Kw	AMP	H x W x L mm	Kg	CODE
JET 1000M	230v	1" x 1"	70/50	1.0	5	190 x 182 x 400	18	022-280
JET 1000T	400v	1" x 1"	70/50	1.0	2.2	190 x 182 x 400	18	022-284
JET 100-68M	230v	1½" x 1"	100/68	1.5	9.8	235 x 220 x 500	29	022-292
JET 100-68T	400v	1½" x 1"	100/68	1.5	3.2	235 x 220 x 500	29	022-293
JET-100-80T	400v	1½" x 1"	100/80	2.2	4.7	235 x 220 x 500	30	022-294

SURFACE MOUNTED PUMPS

PENTAX INOX JET SELF PRIMING CENTRIFUGAL PUMPS

E

Self priming centrifugal pumps for water supplies in small household and industrial systems. Connected to pressure accumulators tanks and pressure switches these can be set up to run automatically. Noryl impeller, technopolymer diffuser and stainless steel body. Clean water only with a maximum liquid temperature of 50°C

Features

High Pressure
Self Priming

Applications

Water Boosting
Washing Systems
Booster Sets

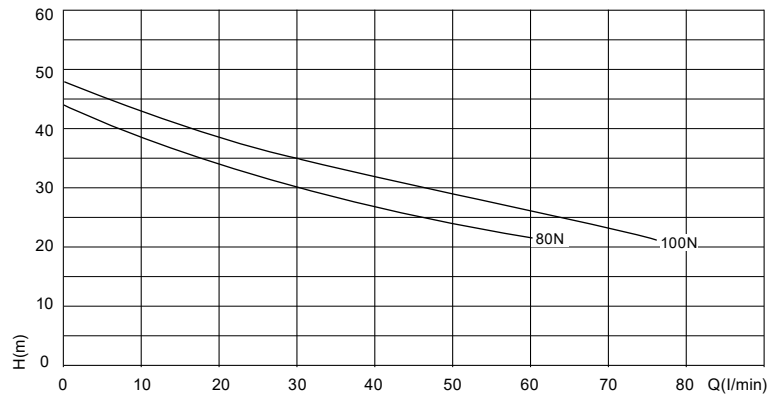

MODEL	VOLT	INLET / OUTLET	LM/HM	Kw	AMP	H x W x L mm	Kg	CODE
INOX 80N	230v	1" x 1"	50/44	0.59	3.3	215 x 175 x 410	9.5	1000-0215
INOX 100N	230v	1" x 1"	65/48	0.74	4.4	215 x 175 x 410	10.5	1000-0225
INOXT 80N	400v	1" x 1"	50/44	0.59	1.4	215 x 175 x 410	9.5	1000-0220
INOXT 100N	400v	1" x 1"	65/48	0.75	1.7	215 x 175 x 410	10.5	1000-0230
INOX 80N	110v	1" x 1"	50/44	0.79	7.4	215 x 175 x 410	8.0	022-285

SURFACE MOUNTED PUMPS

PENTAIR NOCCHI DHI CENTRIFUGAL MULTISTAGE

E

DHI horizontal multistage pumps produce high flow and pressure in performance. Not self priming and should not be allowed to run dry. Stainless steel impellers, diffusers, shaft and seal holder plate. Clean water only with no solids or abrasives and a maximum liquid temperature of 90°C. Examples of uses include water pressure booster systems, irrigation and food and wine industries.

Features

High Pressure

Applications

Water Boosting
Washing Systems
Booster Sets

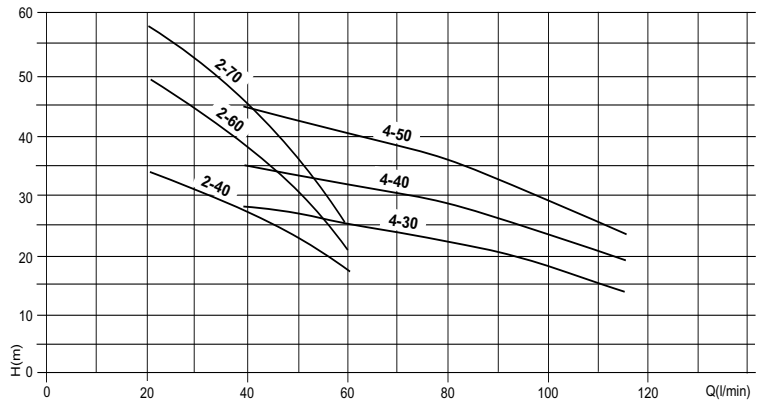

MODEL	VOLTAGE	INLET/ OUTLET	LM/HM	Kw	AMP	H x W x L mm	Kg	CODE
DHI 2-40M	230v	1¼" x 1¼"	60/35	0.4	3.2	220 x 208 x 368	12	422-0240
DHI 2-60M	230v	1¼" x 1¼"	60/50	0.6	4.1	220 x 208 x 396	13	422-0260
DHI 2-70M	230v	1¼" x 1¼"	60/60	0.78	5.2	220 x 208 x 422	13	422-0270
DHI 4-30M	230v	1¼" x 1¼"	120/25	0.5	3.6	220 x 208 x 368	13	422-0430
DHI 4-40M	230v	1¼" x 1¼"	120/35	0.7	4.4	220 x 208 x 396	14	422-0440
DHI 4-50M	230v	1¼" x 1¼"	120/43	0.9	5.8	220 x 208 x 422	17	422-0450
DHI 2-40T	400v	1¼" x 1¼"	60/35	0.4	1.4	220 x 208 x 368	12	422-1240
DHI 2-60T	400v	1¼" x 1¼"	60/50	0.6	1.8	220 x 208 x 396	13	422-1260
DHI 2-70T	400v	1¼" x 1¼"	60/60	0.78	1.8	220 x 208 x 422	13	422-1270
DHI 4-30T	400v	1¼" x 1¼"	120/25	0.5	1.7	220 x 208 x 368	13	422-1430
DHI 4-40T	400v	1¼" x 1¼"	120/35	0.7	2	220 x 208 x 396	14	422-1440
DHI 4-50T	400v	1¼" x 1¼"	120/43	0.9	2	220 x 208 x 422	14	422-1450

SURFACE MOUNTED PUMPS

JET SELF PRIMING PLASTIC & STAINLESS STEEL CENTRIFUGAL PUMPS

E

Jetcom/Pura Kit is ideal for the lifting and distribution of water for irrigation purposes of lawns and flower beds, washing of terraces or outdoor floors. Complete with 4 metres suction kit with check valve and strainer, 20 metres 15mm yellow garden hose, quick release connectors on the outlet of pump, outlet hose and spray nozzle. Pump body, diffuser/venturi system made from technopolymer plastic. Jetinox 550 Kit same as the Jetcom/Pura Kit but comes only with 4m suction kit and has a stainless steel body. Jetinox 45/43, 60/50, 90/50 and Inox 80 have stainless steel pump bodies and technopolymer plastic impeller diffuser/venturi system. Clean water only, maximum suction height of 7 metres with footvalve.

Features

High Pressure
Self Priming

Applications

Water Boosting
Washing Systems
Booster Sets

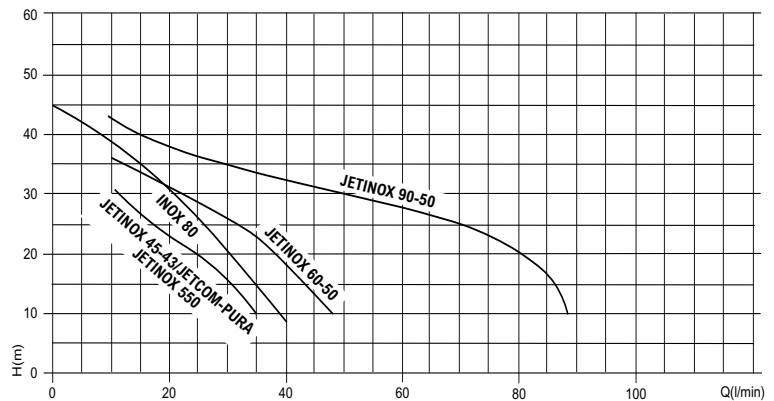

**JETINOX 45/43
60/50
90/50**



INOX 80



JETCOM/PURA KIT



**JETINOX
550 KIT**

MODEL	VOLTAGE	INLET/ OUTLET	LM/HM	Kw	AMP	H x W x L mm	Kg	CODE
JETINOX 45/43	230v	1" x 1"	45/43	0.37	3.0	190 x 178 x 351	8.0	022-253
JETINOX 60/50	230v	1" x 1"	60/50	0.55	4.0	190 x 178 x 351	8.6	022-266
JETINOX 90/50	230v	1¼" x 1"	90/50	0.9	7	260 x 235 x 430	13.0	022-286
INOX 80	110v	1" x 1"	40/45	0.79	7.4	215 x 175 x 410	7.9	022-285
JETCOM/PURA KIT	230v	1" x 1"	40/42	0.55	2.5	240 x 174 x 360	8.1	022-250
JETINOX 550 KIT	230v	1" x 1"	45/42	0.55	2.5	240 x 174 x 360	8.0	022-255

SURFACE MOUNTED PUMPS

PENTAIR NOCCHI MULTI EVO MULTISTAGE PUMPS

E

ADVANTAGES

- Electric pumps in the Multi EVO series offer the following advantages:
- Low energy consumption thanks to high-efficiency hydraulic system.
- High performance
- High-level reliability - thanks to the resistant and innovative design
- Silent operation - improved user comfort thanks to its silent operation
- Compact form
- Wide range

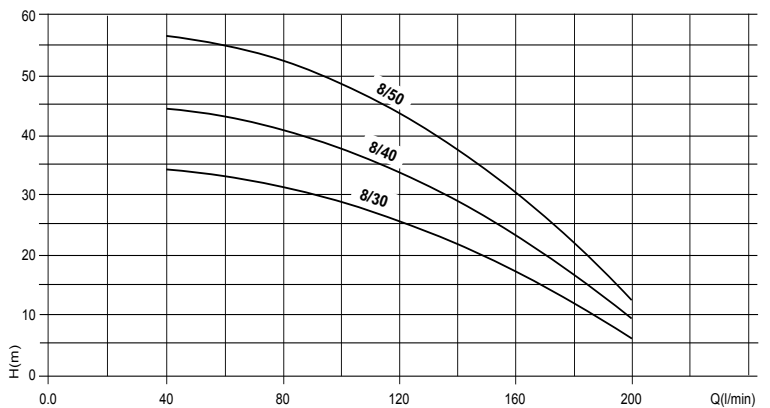
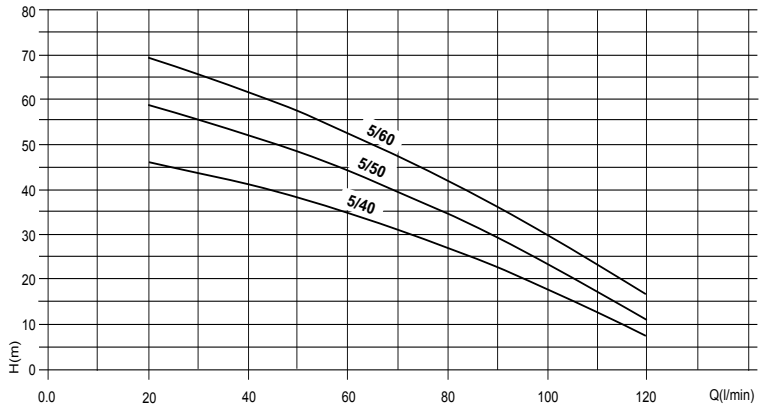
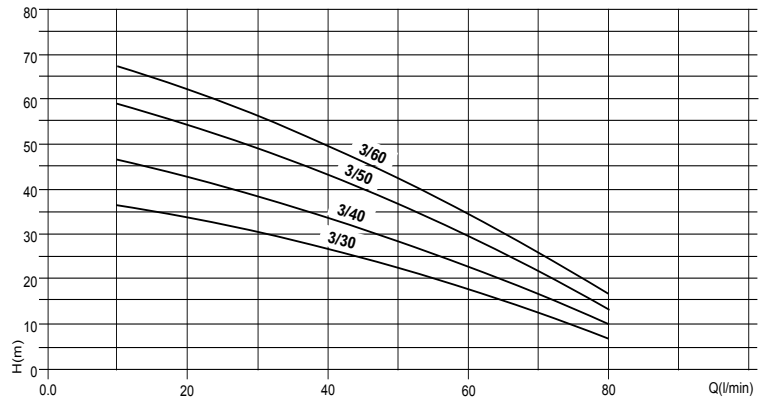

SURFACE MOUNTED PUMPS

PENTAIR NOCCHI MULTI EVO MULTISTAGE PUMPS

E

Multi Evo horizontal multistage pumps produce high flow and pressure in performance. Not self priming and should not be allowed to run dry. Technopolymer impellers and diffusers. Clean water only with no solids or abrasives and a maximum liquid temperature of 50°C. Examples of uses include water pressure booster systems, washing and irrigation.

Features

High Pressure
High Flow

Applications

Water Boosting
Washing Systems
Booster Sets



MODEL	VOLTAGE	INLET/ OUTLET	LM/HM	Kw	AMP	H x W x L mm	Kg	CODE
MULTI EVO 3-30M	230v	1" x 1"	80/36	0.40	2.95	199 x 177 x 356	7	022-210
MULTI EVO 3-40M	230v	1" x 1"	80/46	0.55	3.7	199 x 177 x 356	7	022-220
MULTI EVO 3-50M	230v	1" x 1"	80/58	0.70	4.4	207 x 177 x 400	9	022-027
MULTI EVO 3-60M	230v	1" x 1"	80/67	0.90	5.8	207 x 177 x 422	11	022-026
MULTI EVO 5-40M	230v	1¼" x 1"	120/46	0.75	4.7	207 x 177 x 380	9	022-230
MULTI EVO 5-50M	230v	1¼" x 1"	120/58	0.95	6.2	207 x 177 x 402	11	022-240
MULTI EVO 5-60M	230v	1¼" x 1"	120/69	1.20	7.5	215 x 203 x 457	14	022-195
MULTI EVO 8-30M	230v	1¼" x 1¼"	200/34	0.90	5.9	207 x 177 x 398	11	022-247
MULTI EVO 8-40M	230v	1¼" x 1¼"	200/44	1.20	7.7	215 x 203 x 430	14	022-248
MULTI EVO 8-50M	230v	1¼" x 1¼"	200/56	1.40	9	215 x 203 x 457	15	022-241
MULTI EVO 3-30T	400v	1" x 1"	80/36	0.40	1.3	199 x 177 x 356	7	022-215
MULTI EVO 3-40T	400v	1" x 1"	80/46	0.53	1.55	199 x 177 x 356	7	022-225
MULTI EVO 3-50T	400v	1" x 1"	80/58	0.70	1.9	207 x 177 x 400	9	022-029
MULTI EVO 3-60T	400v	1" x 1"	80/67	0.82	2	207 x 177 x 422	11	022-030
MULTI EVO 5-40T	400v	1¼" x 1"	120/46	0.75	2	207 x 177 x 380	9	022-235
MULTI EVO 5-50T	400v	1¼" x 1"	120/58	0.90	2.1	207 x 177 x 402	11	022-245
MULTI EVO 5-60T	400v	1¼" x 1"	120/69	1.20	3.1	215 x 177 x 457	14	022-205
MULTI EVO 8-30T	400v	1¼" x 1¼"	200/34	0.90	2.1	207 x 177 x 398	11	022-010
MULTI EVO 8-40T	400v	1¼" x 1¼"	200/44	1.18	2.95	215 x 177 x 430	14	022-012
MULTI EVO 8-50T	400v	1¼" x 1¼"	200/56	1.40	4	215 x 177 x 457	15	022-249

SURFACE MOUNTED PUMPS

PENTAIR NOCCHI MULTI EVO-A MULTISTAGE PUMPS

E

Self priming Multi Evo-A series. Horizontal multistage pumps produce high flow and pressure in performance. These pumps should not be allowed to run dry. Technopolymer impellers and diffusers. Clean water only with no solids or abrasives and a maximum liquid temperature of 50°C. Examples of uses include water pressure booster systems, washing and irrigation.

Features

High Pressure
High Flow
Self Priming

Applications

Water Boosting
Washing Systems
Booster Sets

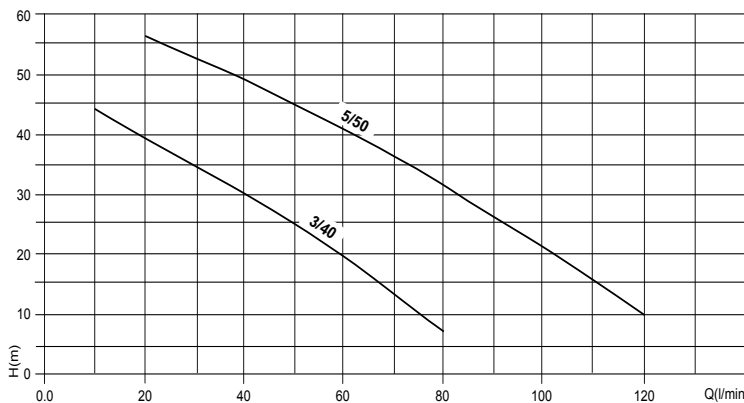

MODEL	VOLTAGE	INLET/OUTLET	LM/HM	Kw	AMP	H x W x L mm	Kg	CODE
MULTI EVO-A 3-40M	230v	1" x 1"	80/46	0.51	3.7	199 x 177 x 380	8	022-190
MULTI EVO-A 5-50M	230v	1" x 1"	120/58	0.95	6.2	207 x 177 x 400	11	022-194
MULTI EVO-A 3-40T	400v	1" x 1"	80/46	0.53	1.55	199 x 177 x 380	8	022-192
MULTI EVO-A 5-50T	400v	1" x 1"	120/58	0.7	1.9	207 x 177 x 400	11	022-196

SURFACE MOUNTED PUMPS

PENTAIR NOCCHI MULTINOX-VE+ VERTICAL MULTISTAGE

E

Multinox VE vertical multistage pumps are used for a range of pressure boosting applications. High performance along with various different pressures available throughout the range. Booster units, single or twin or as a wash down set are just some examples of what this range can offer. Ideal when high performance and compact dimensions are required. Clean water only with no suspended solids or abrasive material. These units cannot be run dry. Maximum liquid temp 50°C. Impellers and diffusers made from technopolymer.

Features

High Pressure
Self Priming

Applications

Water Boosting
Washing Systems
Booster Sets

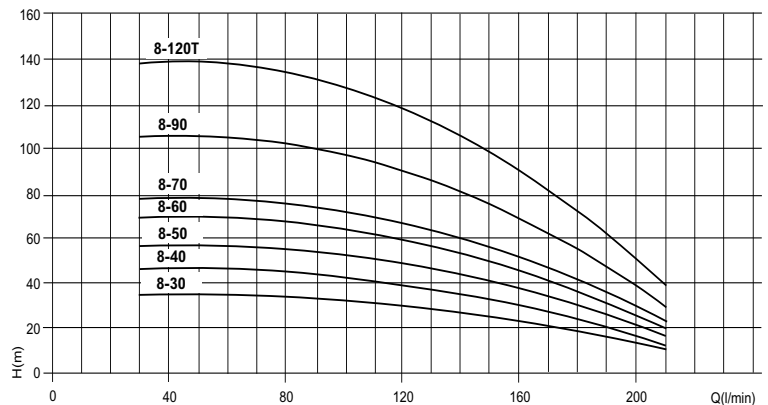

MODEL	VOLTAGE	INLET/ OUTLET	LM/HM	Kw	AMP	H x W x L mm	Kg	CODE
MULTINOX VE+8-30M	230v	1¼" x 1¼"	200/35	1.0	6.3	416 x 204 x 204	19	022-502
MULTINOX VE+8-40M	230v	1¼" x 1¼"	200/45	1.2	7.8	443 x 204 x 204	21	022-504
MULTINOX VE+8-50M	230v	1¼" x 1¼"	200/57	1.5	9.5	470 x 204 x 204	23	022-505
MULTINOX VE+8-30T	400v	1¼" x 1¼"	200/35	1.3	2.3	416 x 204 x 204	19	022-503
MULTINOX VE+8-40T	400v	1¼" x 1¼"	200/45	1.3	2.8	443 x 204 x 204	21	022-506
MULTINOX VE+8-50T	400v	1¼" x 1¼"	200/57	1.5	3.3	470 x 204 x 204	23	022-508
MULTINOX VE+8-60T	400v	1¼" x 1¼"	200/68	1.5	3.8	497 x 204 x 204	25	022-510
MULTINOX VE+8-70T	400v	1¼" x 1¼"	200/80	1.5	4.2	524 x 204 x 204	27	022-511
MULTINOX VE+8-90T	400v	1¼" x 1¼"	200/104	3.0	5.9	730 x 204 x 204	36	022-512
MULTINOX VE+8-120T	400v	1¼" x 1¼"	200/139	4.0	7.6	855 x 204 x 204	39	022-513

SURFACE MOUNTED PUMPS

PENTAX ULTRA S WRAS APPROVED CENTRIFUGAL PUMPS

E

Ultra S multistage pumps produce high flow and pressure in performance. Not self priming and should not be allowed to run dry. Stainless steel impeller, diffusers and pump body. Clean water only with no solids or abrasives. Examples of use include water pressure booster systems, drinking water, washing and irrigation.

Features

WRAS Approved
High Pressure
High Flow

Applications

Drinking Water
Water Boosting
Boosters Sets

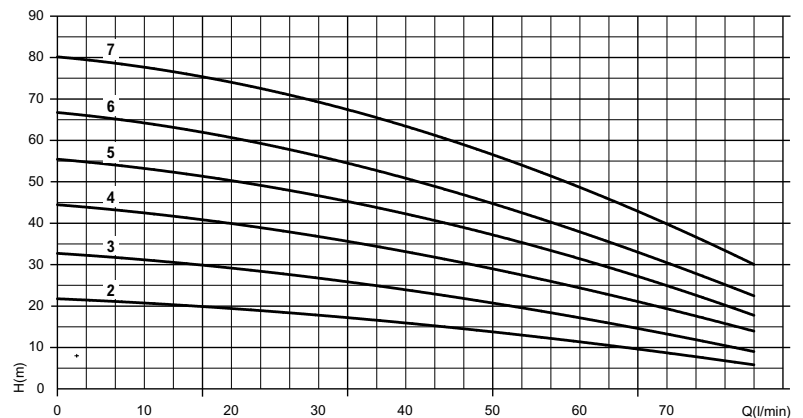

MODEL	VOLTAGE	INLET/OUTLET	LM/HM	Kw	AMPS	H x W x L mm	Kg	CODE
ULTRA 3S-50/2	230v	1" x 1"	80/21	0.37	1.8	190 x 178 x 333	7	1000-1305
ULTRA 3S-70/3	230v	1" x 1"	80/32	0.51	2.7	190 x 178 x 333	8	1000-1315
ULTRA 3S-90/4	230v	1" x 1"	80/44	0.66	3.6	190 x 178 x 357	9	1000-1325
ULTRA 3S-100/5	230v	1" x 1"	80/55	0.75	4.4	203 x 178 x 404	12	1000-1335
ULTRA 3S-120/6	230v	1" x 1"	80/66	0.9	5.1	203 x 178 x 428	13	1000-1345
ULTRA 3S-150/7	230v	1" x 1"	80/80	1.1	6.4	211 x 201 x 483	16	1000-1355
ULTRA 3S-50/2T	400v	1" x 1"	80/21	0.37	0.9	190 x 178 x 333	7	1000-1310
ULTRA 3S-70/3T	400v	1" x 1"	80/32	0.51	1.1	190 x 178 x 333	8	1000-1320
ULTRA 3S-90/4T	400v	1" x 1"	80/44	0.66	1.7	190 x 178 x 357	9	1000-1330
ULTRA 3S-100/5T	400v	1" x 1"	80/55	0.75	1.7	203 x 178 x 404	12	1000-1340
ULTRA 3S-120/6T	400v	1" x 1"	80/66	0.9	2.5	203 x 178 x 428	13	1000-1350
ULTRA 3S-150/7T	400v	1" x 1"	80/80	1.1	2.7	211 x 201 x 483	16	1000-1360

SURFACE MOUNTED PUMPS

PENTAX ULTRA S WRAS APPROVED CENTRIFUGAL PUMPS

E

Ultra S multistage pumps produce high flow and pressure in performance. Not self priming and should not be allowed to run dry. Stainless steel impeller, diffusers and pump body. Clean water only with no solids or abrasives. Example of use include water pressure booster systems, drinking water, washing and irrigation.

Features

WRAS Approved
High Pressure
High Flow

Applications

Drinking Water
Water Boosting
Booster Sets

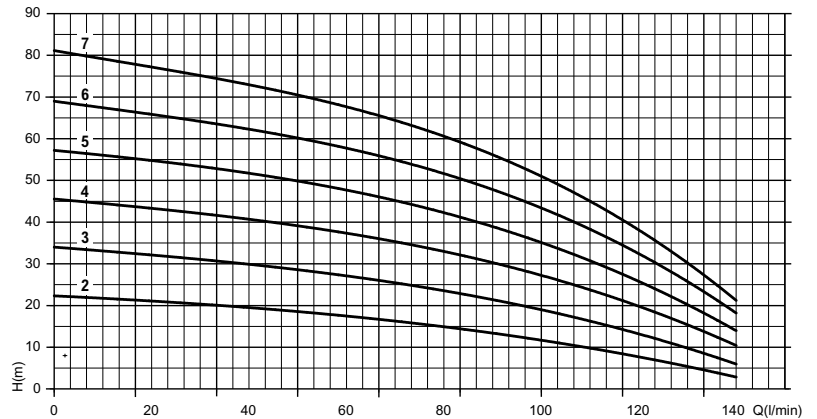

MODEL	VOLTAGE	INLET/OUTLET	LM/HM	Kw	AMP	H x W x L mm	Kg	CODE
U 5S-70/2	230v	1" x 1"	140/22	0.51	2.6	195 x 178 x 333	7.7	1000-1365
U 5S-80/3	230v	1" x 1"	140/34	0.6	3.8	203 x 178 x 357	10.3	1000-1375
U 5S-120/4	230v	1" x 1"	140/45	0.9	4.9	203 x 178 x 380	12.1	1000-1385
U 5S-150/5	230v	1" x 1"	140/57	1.1	6.5	211 x 201 x 436	14.9	1000-1395
U 5S-150/5	110v	1" x 1"	140/57	1.39	13	211 x 201 x 436	14.9	1000-1397
U 5S-180/6	230v	1" x 1"	140/68	1.3	7.3	211 x 201 x 459	16.0	1000-1405
U 5S-200/7	230v	1" x 1"	140/81	1.5	8.7	211 x 201 x 483	18.1	1000-1415
U 5S-70/2T	400v	1" x 1"	140/22	0.51	1.1	195 x 178 x 333	7.7	1000-1370
U 5S-80/3T	400v	1" x 1"	140/34	0.6	1.4	203 x 178 x 357	10.3	1000-1380
U 5S-120/4T	400v	1" x 1"	140/45	0.9	2.4	203 x 178 x 380	12.1	1000-1390
U 5S-150/5T	400v	1" x 1"	140/57	1.1	2.7	211 x 201 x 436	14.9	1000-1400
U 5S-180/6T	400v	1" x 1"	140/68	1.3	3.	211 x 201 x 459	16.0	1000-1410
U 5S-200/7T	400v	1" x 1"	140/81	1.5	3.3	211 x 201 x 483	18.1	1000-1420

SURFACE MOUNTED PUMPS

PENTAX ULTRA S WRAS APPROVED CENTRIFUGAL PUMPS

E

Ultra S multistage pumps produce high flow and pressure in performance. Not self priming and should not be allowed to run dry. Stainless steel impeller, diffusers and pump body. Clean water only with no solids or abrasives. Examples of use include water pressure booster systems, drinking water, washing and irrigation.

Features

WRAS Approved
High Pressure
High Flow

Applications

Drinking Water
Water Boosting
Booster Sets

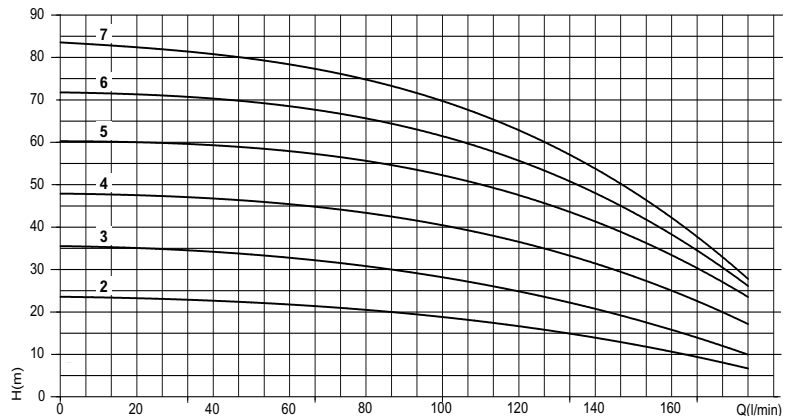

MODEL	VOLTAGE	INLET/OUTLET	LM/HM	Kw	AMP	H x W x L mm	Kg	CODE
U 7S-100/2	230v	1¼" x 1"	180/23	0.75	4.1	203 x 178 x 356	10.6	1000-1425
U 7S-120/3	230v	1¼" x 1"	180/35	0.9	5.5	203 x 178 x 356	11.6	1000-1435
U 7S-180/4	230v	1¼" x 1"	180/48	1.3	7.7	211 x 201 x 411	15.0	1000-1445
U 7S-250/5	230v	1¼" x 1"	180/60	1.85	10.2	211 x 201 x 436	17.3	1000-1455
U 7S-300/6	230v	1¼" x 1"	180/72	2.2	11.4	229 x 201 x 503	20.0	1000-1465
U 7S-100/2T	400v	1¼" x 1"	180/23	0.75	1.6	211 x 201 x 459	10.6	1000-1430
U 7S-120/3T	400v	1¼" x 1"	180/35	0.9	2.5	203 x 178 x 356	11.6	1000-1440
U 7S-180/4T	400v	1¼" x 1"	180/48	1.3	3.1	211 x 201 x 411	15.0	1000-1450
U 7S-250/5T	400v	1¼" x 1"	180/60	1.85	4.1	211 x 201 x 436	17.3	1000-1460
U 7S-300/6T	400v	1¼" x 1"	180/72	2.2	4.8	211 x 201 x 459	20.0	1000-1470
U 7S-350/7T	400v	1¼" x 1"	180/80	2.57	5.1	229 x 201 x 527	20.7	1000-1480

SURFACE MOUNTED PUMPS

PENTAX ULTRA S WRAS APPROVED CENTRIFUGAL PUMPS

E

Ultra S multistage pumps produce high flow and pressure in performance. Not self priming and should not be allowed to run dry. Stainless steel impeller, diffusers and pump body. Clean water only with no solids or abrasives. Examples of use include water pressure booster systems, drinking water, washing and irrigation.

Features

WRAS Approved
High Pressure
High Flow

Applications

Drinking Water
Water Boosting
Booster Sets

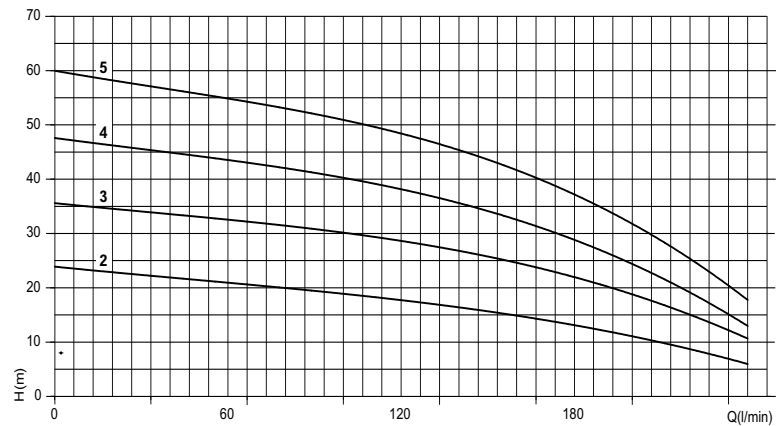

MODEL	VOLTAGE	INLET/OUTLET	LM/HM	Kw	AMP	H x W x L mm	Kg	CODE
U 9S-100/2	230v	1½" x 1¼"	240/23	0.75	4.5	203 x 178 x 375	10.8	1000-1485
U 9S-150/3	230v	1½" x 1¼"	240/35	1.1	6.8	211 x 201 x 375	14.2	1000-1495
U 9S-200/4	230v	1½" x 1¼"	240/47	1.5	8.4	211 x 201 x 436	16.8	1000-1505
U 9S-250/5	230v	1½" x 1¼"	240/60	1.85	10.8	211 x 201 x 464	17.7	1000-1515
U 9S-100/2T	400v	1½" x 1¼"	240/23	0.75	1.6	203 x 178 x 375	10.8	1000-1490
U 9S-150/3T	400v	1½" x 1¼"	240/35	1.1	2.8	211 x 201 x 375	14.2	1000-1500
U 9S-200/4T	400v	1½" x 1¼"	240/47	1.5	3.3	211 x 201 x 436	16.8	1000-1510
U 9S-250/5T	400v	1½" x 1¼"	240/60	1.85	4.3	211 x 201 x 464	17.7	1000-1520

SURFACE MOUNTED PUMPS

PENTAX ULTRA S WRAS APPROVED CENTRIFUGAL PUMPS

E

Ultra S multistage pumps produce high flow and pressure in performance. Not self priming and should not be allowed to run dry. Stainless steel impeller, diffusers and pump body. Clean water only with no solids or abrasives. Examples of use include water pressure booster systems, drinking water, washing and irrigation.

Features

WRAS Approved
High Pressure
High Flow

Applications

Drinking Water
Water Boosting
Booster Sets

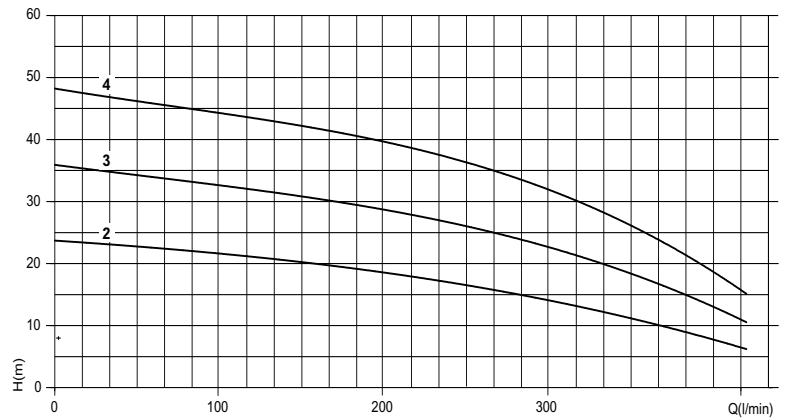

MODEL	VOLTAGE	INLET/OUTLET	LM/HM	Kw	AMP	H x W x L mm	Kg	CODE
U 18S-180/2T	400v	2" x 1½"	400/23	1.3	3	211 x 201 x 432	14.0	1000-1530
U 18S-250/3T	400v	2" x 1½"	400/35	1.85	4.4	211 x 201 x 432	15.8	1000-1540
U 18S-400/4T	400v	2" x 1½"	400/47	3.0	5.7	211 x 201 x 514	22.6	1000-1550

PRESSURE BOOSTING SYSTEMS

SINGLE PUMP BOOSTERS

E

PM45 is a peripheral turbine pump for small household systems and simple industrial applications. Complete with Presscontrol wired to pump. The Presscontrol will automatically turn the pump on and off when an outlet is opened and closed. In the case of no water to protect the pump from dry running it will switch off.

Features

High Pressure
Automatic

Applications

Water Boosting
Washing Systems

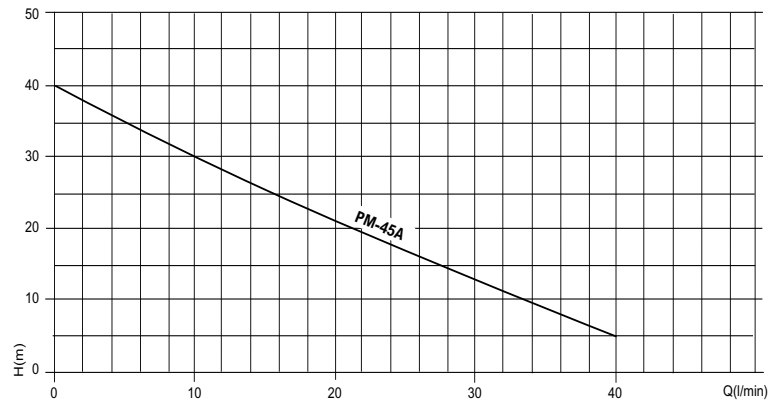

MODEL	VOLTAGE	INLET/OUTLET	LM/HM	Kw	AMP	H x W x L mm	Kg	CODE
PM-45A	230v	1" x 1"	40/40	0.37	2.3	345 x 225 x 260	9	022-402
PM-45A	110v	1" x 1"	40/40	0.37	4.6	345 x 225 x 260	9	022-403

PRESSURE BOOSTING SYSTEMS

SINGLE PUMP BOOSTERS

E

Self priming single pump booster sets complete with pressure switch and mild steel accumulator vessel. Water supply is not always enough to supply the correct amount of water at a suitable pressure, so the best and most affordable solution to solve water deficiency problems is to install a pumped booster system via a 'break' tank. These systems are specifically designed to boost the pressure of the water supply and deliver the correct amount of water to all outlets. The pre-set pressure switch enables it to automatically start and stop the pump. Do not allow to run dry.

Features

High Pressure
Automatic

Applications

Water Boosting
Washing Systems

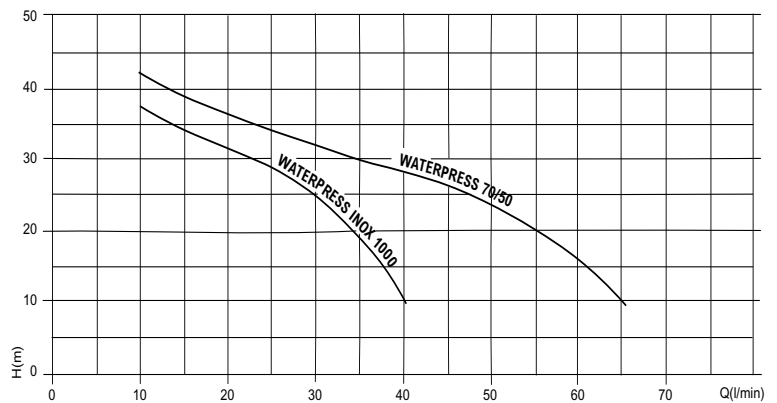

WATERPRESS INOX 1000 60/50



WATERPRESS 70/50

MODEL	VOLT	TANK SIZE	INLET/ OUTLET	LM/HM	Kw	AMP	H x W x L mm	Kg	CODE
W/PRESS INOX 1000 60/50	230v	25L	1" x 1"	55/45	0.55	4	470 x 260 x 510	15	022-463
WATERPRESS 70/50	230v	25L	1" x 1"	65/45	1	5	550 x 315 x 520	22	022-460
WATERPRESS 70/50+	230v	60L	1" x 1"	65/45	1	5	640 x 370 x 640	32	022-461

PRESSURE BOOSTING SYSTEMS

SINGLE PUMP BOOSTERS

E

Self priming single pump booster sets complete with pressure switch and stainless steel accumulator vessel. Water supply is not always enough to supply the correct amount of water at a suitable pressure, so the best and most affordable solution to solve water deficiency problems is to install a pumped booster system via a 'break' tank. These systems are specifically designed to boost the pressure of the water supply and deliver the correct amount of water to all outlets. The pre-set pressure switch enables it to automatically start and stop the pump. Do not allow to run dry.

Features

High Pressure
Automatic

Applications

Water Boosting
Washing Systems

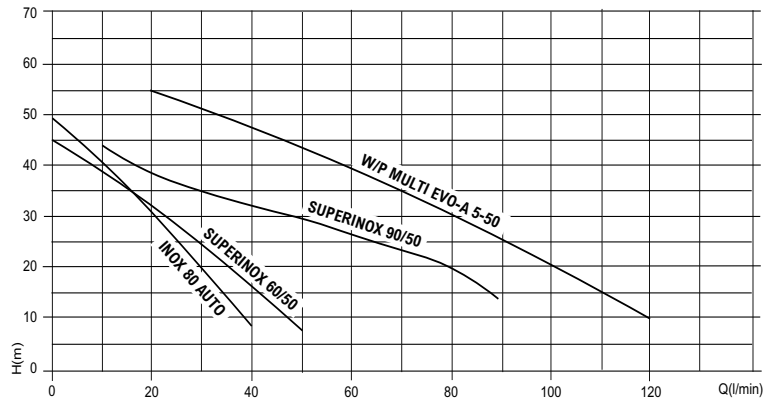

SUPERINOX 60/50



INOX 80 AUTO

MODEL	VOLT	TANK SIZE	INLET/OUTLET	LM/HM	Kw	AMP	H x W x L mm	Kg	CODE
SUPERINOX 60/50	230v	25L	1" x 1"	55/45	0.55	4	550 x 280 x 530	11	022-462
SUPERINOX 90/50	230v	25L	1¼" x 1"	80/45	0.90	7	580 x 280 x 530	15.4	022-464
W/P MULTI EVO-A 5-50M	230v	25L	1" x 1"	100/55	0.95	6.2	550 x 260 x 520	13	022-495
W/P MULTI EVO-A 5-50M+	230v	60L	1" x 1"	100/55	0.95	6.2	640 x 370 x 640	23	022-500
INOX 80 AUTO	110v	25L	1" x 1"	40/45	0.59	9	580 x 280 x 530	12	022-302

PRESSURE BOOSTING SYSTEMS

EASY20 MULTI EVO AUTOMATIC TWIN BOOSTER PUMPS

E

SINGLE PHASE

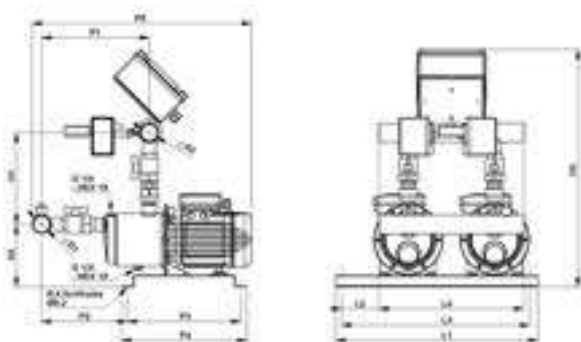

3-PHASE

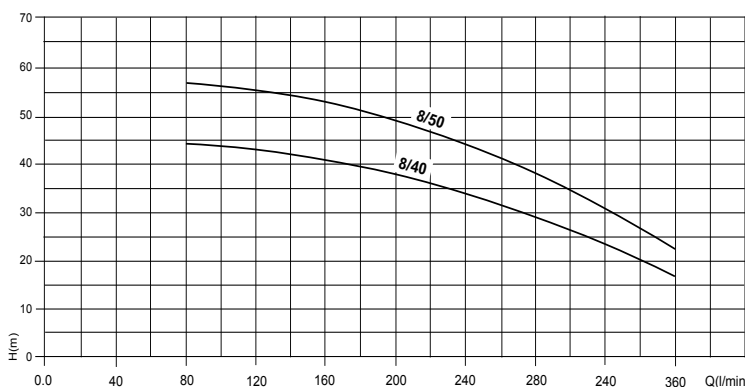
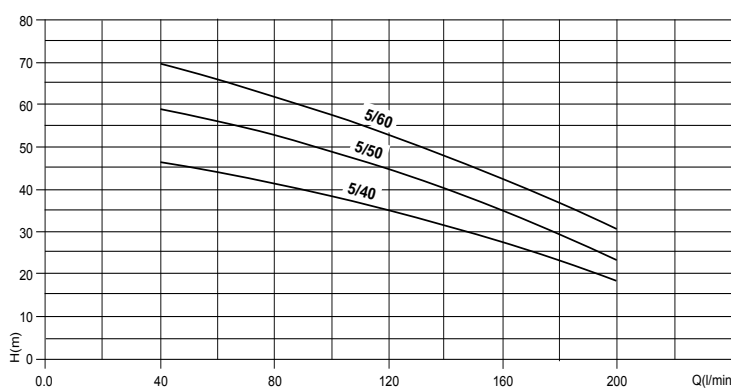
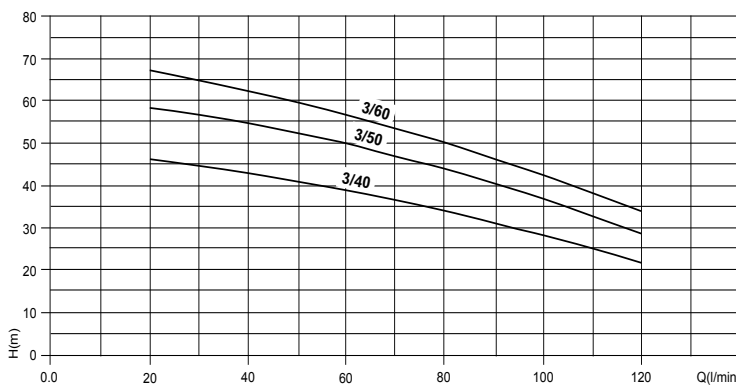
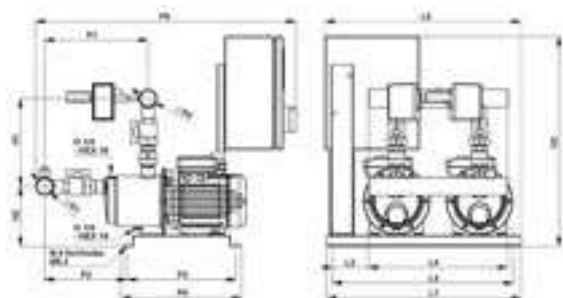

MODEL	DIMENSIONS IN MM															
	L1	L2	L3	L4	L5		P1	P2	P3	P4	P5		H1	H2	H3	
					230v	400v					230v	400v			230v	400v
EASY20/MULTI EVO 3-40M/T	515	95	485	370	-	520	255	196	290	320	525	670	235	160	605	560
EASY20/MULTI EVO 3-50M/T	515	95	485	370	-	520	275	216	290	320	560	690	235	160	605	560
EASY20/MULTI EVO 3-60M/T	515	95	485	370	-	520	297	238	290	320	580	715	235	160	605	560
EASY20/MULTI EVO 5-40M/T	515	95	485	370	-	520	275	222	290	320	560	695	240	155	605	560
EASY20/MULTI EVO 5-50M/T	515	95	485	370	-	520	300	247	290	320	590	695	240	155	605	560
EASY20/MULTI EVO 5-60M/T	515	95	485	370	-	520	320	267	290	320	645	745	240	155	605	560
EASY20/MULTI EVO 8-40M/T	515	95	485	370	-	520	296	240	290	320	620	718	292	155	660	560
EASY20/MULTI EVO 8-50M/T	515	95	485	370	-	520	325	275	290	320	645	745	292	155	660	560

PRESSURE BOOSTING SYSTEMS

EASY20 MULTI EVO AUTOMATIC TWIN BOOSTER PUMPS

E

Easy20 Twin Booster Pump systems for automatic pressurization of water supplies via a break tank. Equipped with either single or three phase pumps. Alternating Duty and Assist Control Panel. Optional low level warning connection. Galvanised suction manifold complete with 2 brass ball valves. Galvanised discharge manifold complete with 2 brass ball valves, 2 check valves 2 pressure switches and pressure gauge. Base in galvanised steel. All units require Pressure Accumulator Vessels (see pages 200 - 203).

Features

Twin Pumps
Alternating Duty

Applications

Boosting
Water Supply



MODEL	VOLTAGE	INLET/OUTLET	LM/HM	Kw P1	AMP	Kg	CODE
EASY20/MULTI EVO 3-40M	230v	1½" x 1½"	120/46	2 x 0.8	2 x 3.7	32.0	2000-0005
EASY20/MULTI EVO 3-50M	230v	1½" x 1½"	120/58	2 x 1.0	2 x 4.4	36.0	2000-0010
EASY20/MULTI EVO 3-60M	230v	1½" x 1½"	120/67	2 x 1.25	2 x 5.8	40.0	2000-0015
EASY20/MULTI EVO 5-40M	230v	2" x 1½"	200/46	2 x 1.1	2 x 4.7	37.0	2000-0020
EASY20/MULTI EVO 5-50M	230v	2" x 1½"	200/58	2 x 1.35	2 x 6.2	40.0	2000-0025
EASY20/MULTI EVO 5-60M	230v	2" x 1½"	200/69	2 x 1.65	2 x 7.5	46.0	2000-0030
EASY20/MULTI EVO 8-40M	230v	2" x 2"	360/44	2 x 1.66	2 x 7.7	48.0	2000-0040
EASY20/MULTI EVO 8-50M	230v	2" x 2"	360/56	2 x 2.0	2 x 9.0	50.0	2000-0045
EASY20/MULTI EVO 3-40T	400v	1½" x 1½"	120/46	2 x 0.78	2 x 1.55	38.0	2000-0050
EASY20/MULTI EVO 3-50T	400v	1½" x 1½"	120/58	2 x 1.0	2 x 1.9	42.0	2000-0055
EASY20/MULTI EVO 3-60T	400v	1½" x 1½"	120/67	2 x 1.17	2 x 2.0	46.0	2000-0060
EASY20/MULTI EVO 5-40T	400v	2" x 1½"	200/46	2 x 1.1	2 x 2.0	43.0	2000-0065
EASY20/MULTI EVO 5-50T	400v	2" x 1½"	200/58	2 x 1.25	2 x 2.1	46.0	2000-0070
EASY20/MULTI EVO 5-60T	400v	2" x 1½"	200/69	2 x 1.57	2 x 3.1	52.0	2000-0075
EASY20/MULTI EVO 8-40T	400v	2" x 2"	360/44	2 x 1.57	2 x 2.95	54.0	2000-0080
EASY20/MULTI EVO 8-50T	400v	2" x 2"	360/56	2 x 1.95	2 x 4.0	56.0	2000-0085

PRESSURE BOOSTING SYSTEMS

PENTAX ULTRA S AUTOMATIC TWIN BOOSTER PUMPS

E

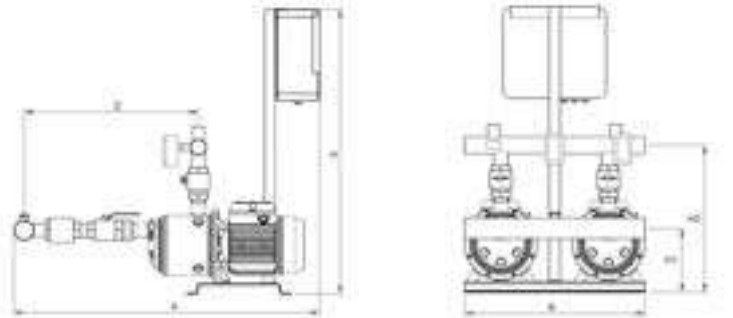
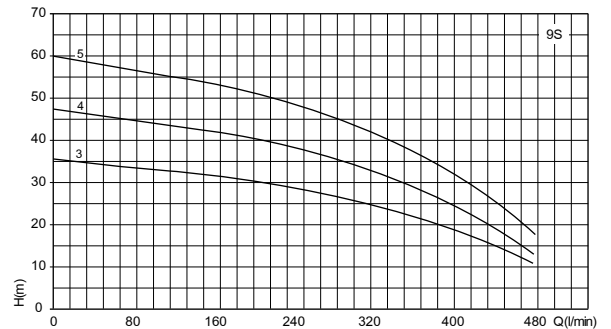
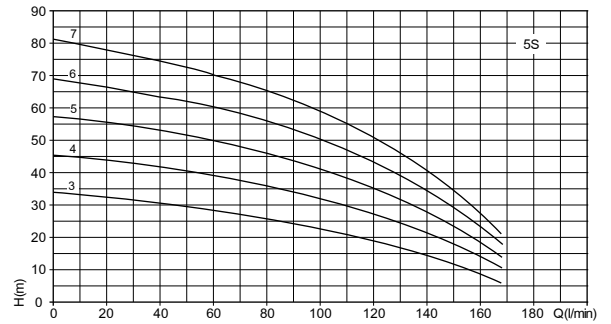
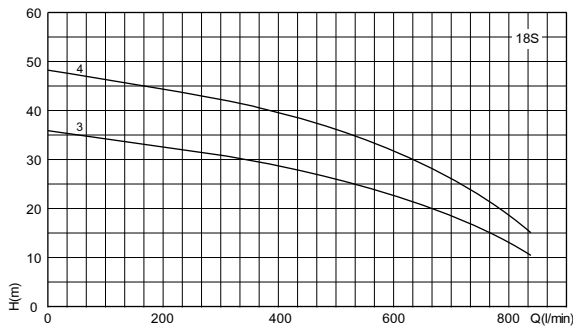
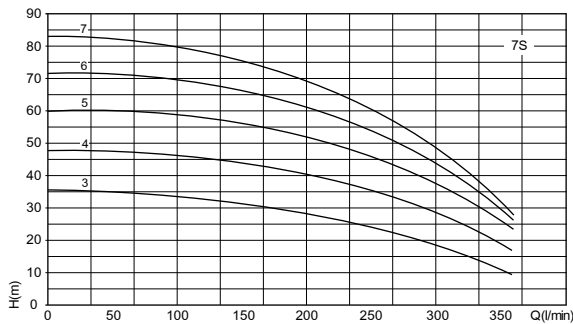
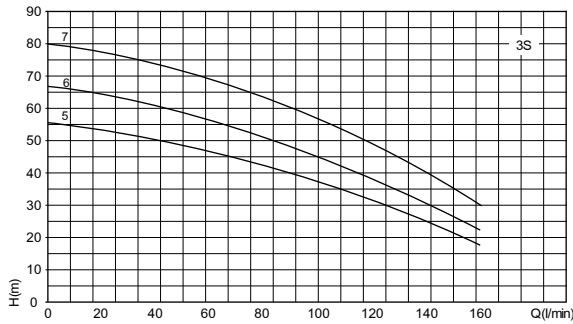

MODEL	A	B	H	D	H1	H2	DNA	DNM	KG
2 U 3 S-100/5T	884	520	738	423	178	376	2"	1½"	45
2 U 3 S-120/6T	908	520	738	447	178	376	2"	1½"	47
2 U 3 S-150/7T	932	520	738	471	184	382	2"	1½"	52
2 U 5 S-80/3T	836	520	738	375	178	376	2"	1½"	41
2 U 5 S-120/4T	860	520	738	399	178	376	2"	1½"	45
2 U 5 S-150/5T	884	520	738	423	184	382	2"	1½"	50
2 U 5 S-180/6T	908	520	738	447	184	382	2"	1½"	54
2 U 5 S-200/7T	932	520	738	471	184	382	2"	1½"	57
2 U 7 S-120/3T	1010	520	738	541	142	434	2½"	2"	55
2 U 7 S-180/4T	1034	520	738	565	148	440	2½"	2"	59
2 U 7 S-250/5T	1058	520	738	589	148	440	2½"	2"	64
2 U 7 S-300/6T	1082	520	738	613	148	440	2½"	2"	68
2 U 7 S-350/7T	1106	520	738	637	153	445	2½"	2"	72
2 U 9 S-150/3T	979	520	738	506	148	400	2½"	2"	55
2 U 9 S-200/4T	1009	520	738	536	148	400	2½"	2"	59
2 U 9S-250/5T	1039	520	738	566	148	400	2½"	2"	62
2 U 18 S-250/3T	1101	520	738	592	148	516	3"	2½"	71
2 U 18 S-400/4T	1139	520	738	629	153	521	3"	2½"	82

SURFACE MOUNTED PUMPS

PENTAX ULTRA S AUTOMATIC TWIN PUMP BOOSTER PUMPS

E

2 Ultra twin booster sets using the Ultra S WRAS approved pumps with stainless steel impellers and diffusers. Stainless steel manifolds are included. Used for automatic pressurization of water supplies via a break tank. Equipped with either single or three phase pumps. Alternating duty and assist. Optional low level warning. All units require pressure accumulator vessels (see pages 200 - 203)

Features

Twin Pumps
Alternating Duty

Applications

Water Boosting
Water Supply



MODEL		LM/HM	Kw	AMP		CODE	CODE
230v	400v			1~	3~	230v	400v
2 U 3 S-100/5	2 U 3 S-100/5T	160/55	2 x 0.75	2 x 4.4	2 x 1.7	1000-4005	1000-4010
2 U 3 S-120/6	2 U 3 S-120/6T	160/66	2 x 0.9	2 x 5.1	2 x 2.5	1000-4015	1000-4020
2 U 3 S-150/7	2 U 3 S-150/7T	160/80	2 x 1.1	2 x 6.4	2 x 2.7	1000-4025	1000-4030
2 U 5 S-80/3	2 U 5 S-80/3T	280/34	2 x 0.6	2 x 3.8	2 x 1.4	1000-4035	1000-4040
2 U 5 S-120/4	2 U 5 S-120/4T	280/45	2 x 0.9	2 x 4.9	2 x 2.4	1000-4045	1000-4050
2 U 5 S-150/5	2 U 5 S-150/5T	280/57	2 x 1.1	2 x 6.5	2 x 2.7	1000-4055	1000-4060
2 U 5 S-180/6	2 U 5 S-180/6T	280/69	2 x 1.3	2 x 7.3	2 x 3.0	1000-4065	1000-4070
2 U 5 S-200/7	2 U 5 S-200/7T	280/80	2 x 1.5	2 x 8.7	2 x 3.3	1000-4075	1000-4080
2 U 7 S-120/3	2 U 7 S-120/3T	360/35	2 x 0.9	2 x 5.6	2 x 2.5	1000-4085	1000-4090
2 U 7 S-180/4	2 U 7 S-180/4T	360/47	2 x 1.3	2 x 7.7	2 x 3.1	1000-4095	1000-4100
-	2 U 7 S-250/5T	360/60	2 x 1.85	2 x 10.2	2 x 4.1	-	1000-4110
-	2 U 7 S-300/6T	360/71	2 x 2.2	2 x 11.4	2 x 4.8	-	1000-4120
-	2 U 7 S-350/7T	360/83	2 x 2.57	-	2 x 5.1	-	1000-4130
2 U 9 S-150/3	2 U 9 S-150/3T	480/35	2 x 1.1	2 x 6.8	2 x 2.8	1000-4135	1000-4140
2 U 9 S-200/4	2 U 9 S-200/4T	480/47	2 x 1.5	2 x 8.4	2 x 3.3	1000-4145	1000-4150
-	2 U 9S-250/5T	480/60	2 x 1.85	2 x 10.8	2 x 4.3	-	1000-4160
-	2 U 18 S-250/3T	800/36	2 x 1.85	-	2 x 4.4	-	1000-4170
-	2 U 18 S-400/4T	800/47	2 x 3.0	-	2 x 5.7	-	1000-4180

PRESSURE BOOSTING SYSTEMS

PENTAIR NOCCHI PMD20 PVM AUTOMATIC TWIN BOOSTER PUMPS

E

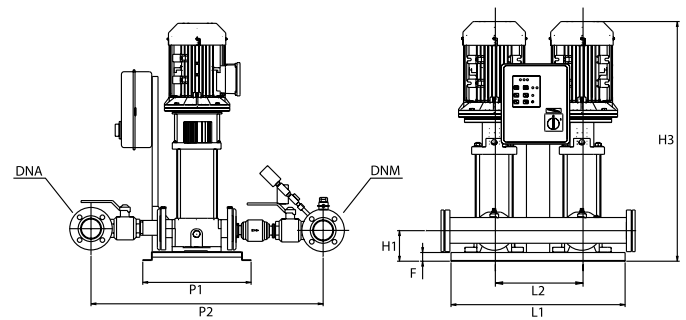
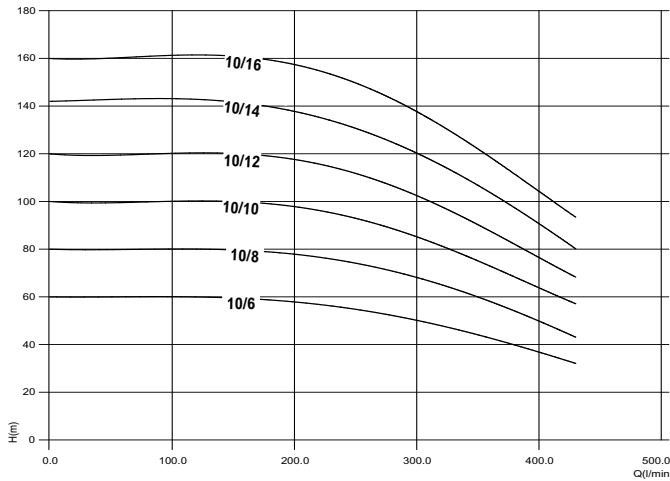
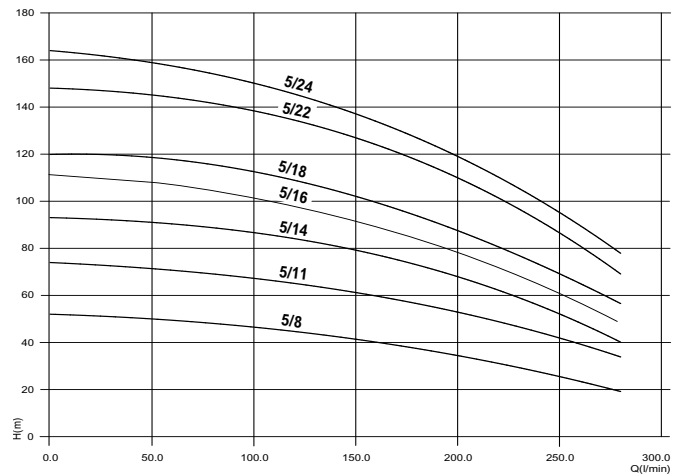
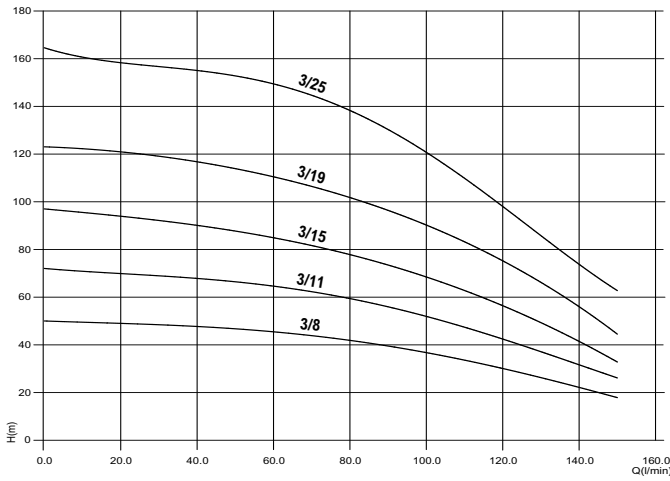

MODEL	DIMENSIONS IN MM							
	L1	P1	P2	H1	H2	H3	F	L2
PMD20 PVM 3-8	600	320	620	80	775	610	30	370
PMD20 PVM 3-11	600	320	620	80	775	664	30	370
PMD20 PVM 3-15	600	320	620	80	775	736	30	370
PMD20 PVM 3-19	600	320	620	80	775	880	30	370
PMD20 PVM 3-25	600	320	620	80	775	988	30	370
PMD20 PVM 5-8	600	320	620	80	775	682	30	370
PMD20 PVM 5-11	600	320	620	80	775	835	30	370
PMD20 PVM 5-14	600	320	620	80	775	916	30	370
PMD20 PVM 5-16	600	320	620	80	775	970	30	370
PMD20 PVM 5-18	600	320	620	80	775	1053	30	370
PMD20 PVM 5-22	600	320	620	80	775	1171	30	370
PMD20 PVM 5-24	600	320	620	80	775	1225	30	370
PMD20 PVM 10-6	620	320	720	120	775	774	30	370
PMD20 PVM 10-8	680	320	720	120	775	864	30	370
PMD20 PVM 10-10	680	320	720	120	775	934	30	370
PMD20 PVM 10-12	680	320	720	120	775	994	30	370
PMD20 PVM 10-14	680	320	720	120	775	1122	30	370
PMD20 PVM 10-16	680	320	720	120	775	1182	30	370

PRESSURE BOOSTING SYSTEMS

PENTAIR NOCCHI PMD20 PVM AUTOMATIC TWIN BOOSTER PUMPS 400V

E

Pressomat PMD20 PVM twin booster sets for the pressurization and delivery of water supplies via a break tank. Equipped with three phase pumps. Single phase options are available. Controlled by two pressure switches with adjustable settings and a control panel for alternating duty, assist and optional low level warning connection. Stainless steel suction manifold complete with 2 brass ball valves and two checks valves. Stainless steel discharge manifold complete with 2 brass ball valves, 2 pressure switches and pressure gauge. Base in galvanised steel. All units require Pressure Accumulator Vessels (see pages 200 - 203). Larger twin booster sets are available up to 1300 litres per min.



MODEL	VOLTAGE	INLET/OUTLET	MAX LM/HM	Kw	AMP	Kg	CODE
PMD20 PVM 3-8	400v	2" x 2"	150/50	2 x 0.75	2 x 2.1	74	2000-0200
PMD20 PVM 3-11	400v	2" x 2"	150/70	2 x 1.1	2 x 3.0	80	2000-0205
PMD20 PVM 3-15	400v	2" x 2"	150/96	2 x 1.1	2 x 3.0	95	2000-0210
PMD20 PVM 3-19	400v	2" x 2"	150/122	2 x 1.5	2 x 3.0	106	2000-0215
PMD20 PVM 3-25	400v	2" x 2"	150/164	2 x 2.2	2 x 4.6	122	2000-0220
PMD20 PVM 5-8	400v	2" x 2"	280/51	2 x 1.1	2 x 3.0	78	2000-0225
PMD20 PVM 5-11	400v	2" x 2"	280/75	2 x 2.2	2 x 4.6	83	2000-0230
PMD20 PVM 5-14	400v	2" x 2"	280/92	2 x 2.2	2 x 4.6	90	2000-0235
PMD20 PVM 5-16	400v	2" x 2"	280/107	2 x 2.2	2 x 4.6	95	2000-0240
PMD20 PVM 5-18	400v	2" x 2"	280/120	2 x 3.0	2 x 5.6	100	2000-0245
PMD20 PVM 5-22	400v	2" x 2"	280/148	2 x 4.0	2 x 7.0	110	2000-0250
PMD20 PVM 5-24	400v	2" x 2"	280/164	2 x 4.0	2 x 7.0	115	2000-0255
PMD20 PVM 10-6	400v	2½" x 2½"	430/60	2 x 2.2	2 x 4.6	120	2000-0260
PMD20 PVM 10-8	400v	2½" x 2½"	430/80	2 x 3.0	2 x 5.6	136	2000-0265
PMD20 PVM 10-10	400v	2½" x 2½"	430/100	2 x 4.0	2 x 7.0	146	2000-0270
PMD20 PVM 10-12	400v	2½" x 2½"	430/120	2 x 4.0	2 x 7.0	160	2000-0275
PMD20 PVM 10-14	400v	2½" x 2½"	430/142	2 x 5.5	2 x 10.0	170	2000-0280
PMD20 PVM 10-16	400v	2½" x 2½"	430/160	2 x 5.5	2 x 10.0	180	2000-0285

PRESSURE BOOSTING SYSTEMS

APM203 VSD VARIABLE SPEED BOOSTER PUMP

E

AMP203 VSD has been designed with the end user in mind. No more complicated menu associated with other designed VSD. Almost all programming is set up ready to go, all you have to do is plumb in the pump, prime, set the pressure and its ready to go. Ideal for home water boosting, irrigation and small industrial applications. Flow rate of up to 80 litres per min, vertical heads up to 50m (5 Bar). Built in dry run protection, pressure vessel and pressure transducer. Not self priming, needs to be flooded suction. Liquid temperature range from 0° c to + 60° c. Easy to read digital display. Built in non return valves. 1" BSP connections.

Features

Variable Speed
Low Power Consumption

Applications

Water Boosting
Irrigation
Small Industrial Applications

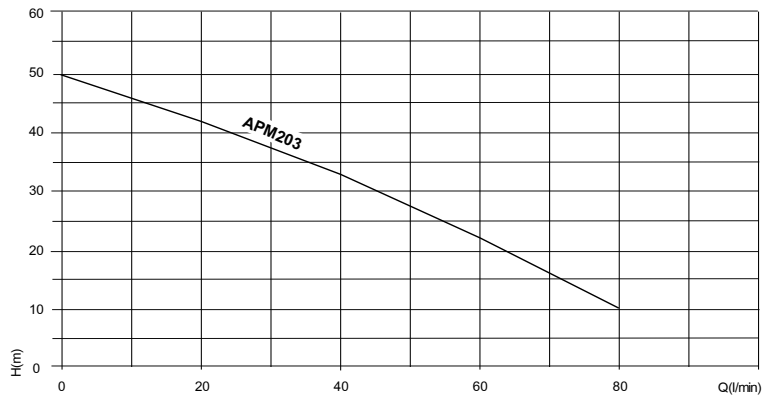

MODEL	VOLT	INLET/ OUTLET	LM/HM	Kw	AMP	H x W x L mm	Kg	CODE
APM23 VSD	230v	1" x 1"	80/50	0.8	4.6	240 x 183 x 404	6.6	050-580

PRESSURE BOOSTING SYSTEMS

SUPERDOMUS + EPIC VARIABLE SPEED DRIVE

E

Single pump booster sets complete with the EPIC variable speed control, cable, transducer, 5 way fitting, gauge and 8 litre vessel all connected to the pump. The EPIC controller controls the operation of the pump in order to maintain constant pressure at various conditions of use. Energy and cost savings, overload protection, dry running protection and simple set up. Not self priming, needs to be flooded suction.

Features

Variable Speed
Energy Saving

Applications

Domestic
Small Industrial



MODEL	VOLT	INLET/ OUTLET	LM/HM	Kw	MAX AMP	H x W x L mm	Kg	CODE
SUPERDOMUS VSD INOX 80	230v	1" x 1"	40/45	0.74	3.7	610 x 175 x 380	11	1000-6200
SUPERDOMUS VSD ULTRA 3S 100/5	230v	1" x 1"	80/50	1.8	4.4	580 x 170 x 420	15	1000-6210
SUPERDOMUS VSD ULTRA 5S 150/5	230v	1" x 1"	140/55	1.8	6.5	580 x 170 x 420	18	1000-6215
SUPERDOMUS VSD ULTRA 7S 250/5	230v	1¼" x 1"	180/55	1.8	10.2	590 x 170 x 440	21	1000-6220
SUPERDOMUS VSD ULTRA 9S 200/4	230v	1½" x 1"	240/45	1.5	8.4	590 x 180 x 440	20	1000-6225

PRESSURE BOOSTING SYSTEMS

PENTAX ULTRA S TWIN BOOSTER PUMPS

E

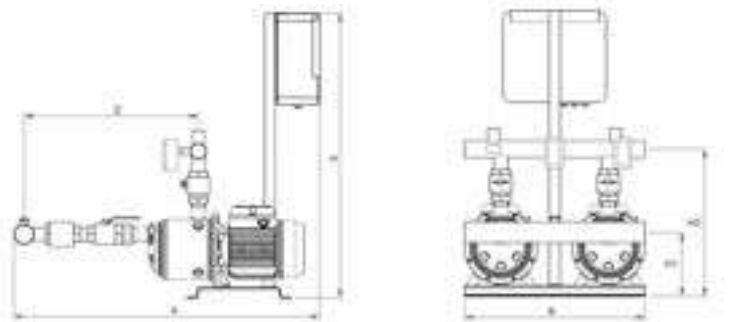
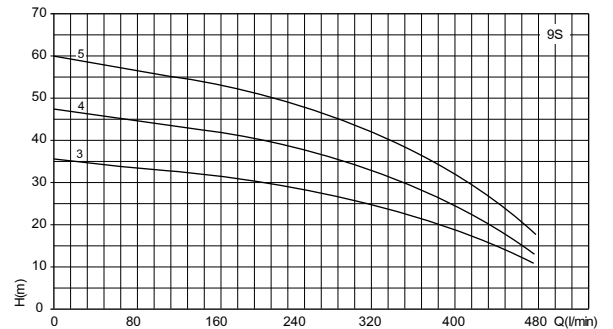
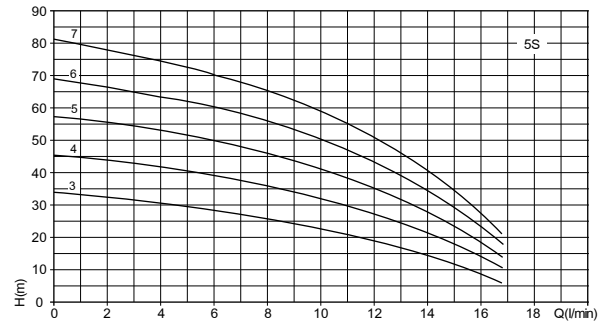
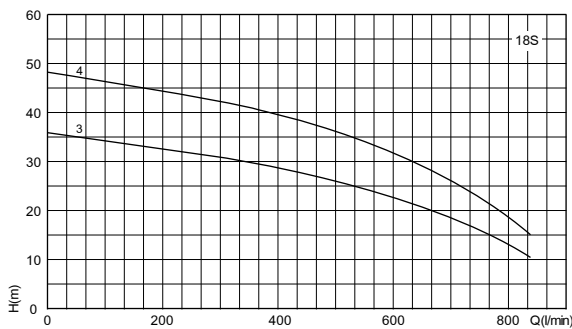
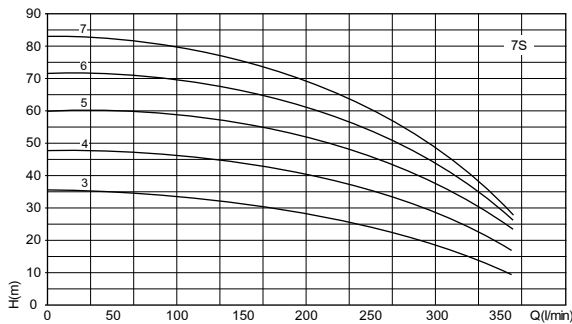
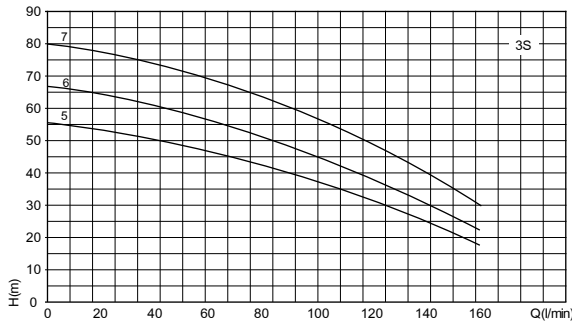

MODEL	A	B	H	D	H1	H2	DNA	DNM	KG
2 U 3 S-100/5T+	884	520	738	423	178	376	2"	1½"	50
2 U 3 S-120/6T+	908	520	738	447	178	376	2"	1½"	52
2 U 3 S-150/7T+	932	520	738	471	184	382	2"	1½"	57
2 U 5 S-80/3T+	836	520	738	375	178	376	2"	1½"	46
2 U 5 S-120/4T+	860	520	738	399	178	376	2"	1½"	50
2 U 5 S-150/5T+	884	520	738	423	184	382	2"	1½"	55
2 U 5 S-180/6T+	908	520	738	447	184	382	2"	1½"	59
2 U 5 S-200/7T+	932	520	738	471	184	382	2"	1½"	62
2 U 7 S-120/3T+	1010	520	738	541	142	434	2½"	2"	60
2 U 7 S-180/4T+	1034	520	738	565	148	440	2½"	2"	64
2 U 7 S-250/5T+	1058	520	738	589	148	440	2½"	2"	69
2 U 7 S-300/6T+	1082	520	738	613	148	440	2½"	2"	73
2 U 7 S-350/7T+	1106	520	738	637	153	445	2½"	2"	75
2 U 9 S-150/3T+	979	520	738	506	148	400	2½"	2"	60
2 U 9 S-200/4T+	1009	520	738	536	148	400	2½"	2"	64
2 U 9 S-250/5T+	1039	520	738	566	148	400	2½"	2"	67
2 U 18 S-250/3T+	1101	520	738	592	148	516	3"	2½"	76
2 U 18 S-400/4T+	1139	520	738	629	153	521	3"	2½"	87

SURFACE MOUNTED PUMPS

PENTAX ULTRA S AUTOMATIC TWIN PUMP BOOSTER VARIABLE SPEED DRIVE

E

2 Ultra twin variable speed booster sets using the Ultra S WRAS approved pumps with stainless steel impellers and diffusers. Stainless steel manifolds are included. Used for automatic pressurization of water supplies via a break tank. Alternating duty and assist. All units require pressure accumulator vessels (see pages 200 - 203)

Features

Twin Pumps
Alternating Duty

Applications

Water Boosting
Water Supply



MODEL		LM/HM	Kw	AMP		CODE 230v	CODE 400v
230v	400v			1~	3~		
2 U 3 S-100/5+	2 U 3 S-100/5T+	160/55	2 x 0.75	2 x 4.4	2 x 1.7	1100-0010	1100-0075
2 U 3 S-120/6+	2 U 3 S-120/6T+	160/66	2 x 0.9	2 x 5.1	2 x 2.5	1100-0015	1100-0080
2 U 3 S-150/7+	2 U 3 S-150/7T+	160/80	2 x 1.1	2 x 6.4	2 x 2.7	1100-0020	1100-0085
2 U 5 S-80/3+	2 U 5 S-80/3T+	280/34	2 x 0.6	2 x 3.8	2 x 1.4	1100-0025	1100-0090
2 U 5 S-120/4+	2 U 5 S-120/4T+	280/45	2 x 0.9	2 x 4.9	2 x 2.4	1100-0030	1100-0095
2 U 5 S-150/5+	2 U 5 S-150/5T+	280/57	2 x 1.1	2 x 6.5	2 x 2.7	1100-0035	1100-0100
2 U 5 S-180/6+	2 U 5 S-180/6T+	280/69	2 x 1.3	2 x 7.3	2 x 3.0	1100-0040	1100-0105
2 U 5 S-200/7+	2 U 5 S-200/7T+	280/80	2 x 1.5	2 x 8.7	2 x 3.3	1100-0045	1100-0110
2 U 7 S-120/3+	2 U 7 S-120/3T+	360/35	2 x 0.9	2 x 5.6	2 x 2.5	1100-0050	1100-0115
2 U 7 S-180/4+	2 U 7 S-180/4T+	360/47	2 x 1.3	2 x 7.7	2 x 3.1	1100-0055	1100-0120
-	2 U 7 S-250/5T+	360/60	2 x 1.85	2 x 10.2	2 x 4.1	-	1100-0125
-	2 U 7 S-300/6T+	360/71	2 x 2.2	2 x 11.4	2 x 4.8	-	1100-0130
-	2 U 7 S-350/7T+	360/83	2 x 2.57	-	2 x 5.1	-	1100-0135
2 U 9 S-150/3+	2 U 9 S-150/3T+	480/35	2 x 1.1	2 x 6.8	2 x 2.8	1100-0060	1100-0140
2 U 9 S-200/4+	2 U 9 S-200/4T+	480/47	2 x 1.5	2 x 8.4	2 x 3.3	1100-0065	1100-0145
-	2 U 9 S-250/5T+	480/60	2 x 1.85	2 x 10.8	2 x 4.3	-	1100-0150
-	2 U 18 S-250/3T+	800/36	2 x 1.85	-	2 x 4.4	-	1100-0160
-	2 U 18 S-400/4T+	800/47	2 x 3.0	-	2 x 5.7	-	1100-0165

PRESSURE BOOSTING SYSTEMS

ECODRIVE VSD

D

Variable speed driver for a single phase pump. 230v IN and 230v OUT. Easy to set up and operate as it is only necessary to connect and the select the set point pressure. Built in pressure sensor and current sensor with digital reading. (ART) Automatic Reset Test. If the device has stopped due to dry run operation, the ART tries to restart the pump periodically to see if the water has returned. Maximum 133 L/M

Features

Variable Speed
Adjustable Pressure
Pressure Range 0.5-8.0 Bar

Applications

Water Boosting
Irrigation
Small Industrial Applications



MODEL	VOLT IN	VOLT OUT	INLET/OUTLET	MAX AMP	H x W x L mm	Kg	CODE
ECO DRIVE	230v	1 x 230v	1" x 1"	7.5	196 x 178 x 262	2.5	9000-0110

SPEEDMATIC EASY VSD

D

Variable speed drivers for a single phase pump or three phase pump. 230v IN and either 230v OUT or 230v 3 phase out. These can be mounted individually or in a group of 2 communicating and operating in MASTER-SLAVE mode with alternating sequence of operation. Easy to set up and operate as it is only necessary to connect and the select the set point pressure. Built in pressure sensor and current sensor with digital reading. (ART) Automatic Reset Test. If the device has stopped due to dry run operation, the ART tries to restart the pump periodically to see if the water has returned. Maximum 166 L/M

Features

Variable Speed
Adjustable Pressure
Pressure Range 0.5-8.0 Bar

Applications

Single & Twin Boosters
Water Boosting



MODEL	VOLT IN	VOLT OUT	INLET/OUTLET	MAX AMP	H x W x L mm	Kg	CODE
EASY 14MM	230v	1 x 230v	1¼" x 1¼"	14	196 x 178 x 262	2.5	9000-0125
EASY 10MT	230v	230v 3 Ph	1¼" x 1¼"	10	196 x 178 x 262	2.5	9000-0130

PRESSURE BOOSTING SYSTEMS

SPEEDMATIC MASTER 101110 VSD

D

Variable speed driver for a single phase pump or three phase pump. 230v IN and either 230v OUT or 230v 3 phase out. These can be mounted individually or in a group of 2, 3 or 4 pumps communicating and operating in MASTER-SLAVE mode with alternating sequence of operation. The communication of 2 devices is direct using cables. The communication of 3 or 4 units is carried out through a centre control communication – ask for details. Easy to set up and operate as it is only necessary to connect and the select the set point pressure. Built in pressure sensor and current sensor with digital reading. (ART) Automatic Reset Test. If the device has stopped due to dry run operation, the ART tries to restart the pump periodically to see if the water has returned. Maximum 166 L/M

Features

Variable Speed
Adjustable Pressure
Pressure Range 0.5-12 Bar

Applications

Water Boosting
Single & Twin Boosters



MODEL	VOLT IN	VOLT OUT	INLET/OUTLET	MAX AMP	H x W x L mm	Kg	CODE
101110	230v	230v OR 230v 3 Ph	1¼" x 1¼"	9A / 10A	196 x 178 x 262	2.5	9000-0140

SPEEDMATIC MASTER 1309 VSD

D

Variable speed driver for one three phase 400v pump. 400v IN 400v 3 phase out These can be mounted individually or in a group of 2, 3 or 4 pumps communicating and operating in MASTER-SLAVE mode with alternating sequence of operation. The communication of 2 devices is direct using cables. The communication of 3 or 4 units is carried out through a centre control communication – ask for details. Easy to set up and operate as it is only necessary to connect and the select the set point pressure. Built in pressure sensor and current sensor with digital reading. (ART) Automatic Reset Test. If the device has stopped due to dry run operation, the ART tries to restart the pump periodically to see if the water has returned. Maximum 250 L/M

Features

Variable Speed
Adjustable Pressure
Pressure Range 0.5-12 Bar

Applications

Water Boosting
Single & Twin Boosters



MODEL	VOLT IN	VOLT OUT	INLET/OUTLET	MAX AMP	H x W x L mm	Kg	CODE
1309	400v	400v 3 Ph	1¼" x 1¼"	9	240 x 226 x 280	5	9000-0150



**CENTRIFUGAL PUMPS IN CONFORMANCE WITH DIN 24255
FOR USE IN THE CIVIL, AGRICULTURAL AND INDUSTRIAL FIELDS**

The CM series is made up of single stage electric monobloc pumps with a flanged hydraulic/motor connection. The pump casing is manufactured in accordance with the provisions of DIN 24255-NF E 44 III-UNI 7467 standards, regarding hydraulic dimensions and connection points.

The pumps may be installed in all positions, except where the suction point is directed downwards.

The design of these machines allows the rotating parts and the motor to be removed from the pump casing without having to disconnect the pipes. Thus any maintenance is easily and quickly performed.

Standard Design Features:

Cast iron pump casing, motor bracket and impeller. Stainless steel shaft. Mechanical seal with ceramic/graphite counterfaces. Flanged connection points DN32 – DN80 2236 PN10 standards.

Threaded type counter flanges UNI 2254.

Clean water pumping only, non aggressive, non explosive and free from abrasives and fibres.

Liquid temperature from -10°C to 90°C . Environmental temperature up to 40°C max.

Maximum operating pressure 10 bar.

Applications include:

Irrigation supply, heating and air conditioning systems, water supply, liquid transfer and fire fighting systems.

SURFACE MOUNTED PUMPS

CM DIN 24255

Dimensions (mm)

DN	D	K	Holes	
			n°	Dia.
32	140	100	4	18
40	150	110	4	18
50	165	125	4	18
65	185	145	4	18
80	200	160	8	18
100	220	180	8	18
125	250	210	8	18

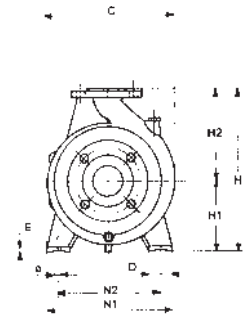
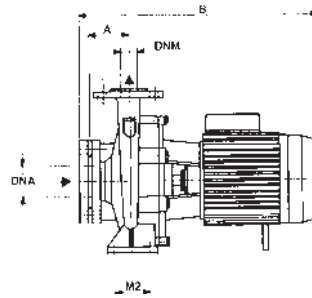
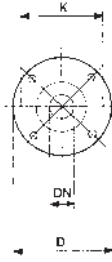

Model	Dimensions (mm)															Weight Kg	
	DNM	DNA	A	H ₁	H ₂	M ₁	M ₂	N ₁	N ₂	D	E	Ø	B	C	H		
CM 32/160	C	B	A	80	132	160	100	70	240	190	50	12	14	490	240	292	41
																	44
																	47
CM 32/200	C	B	A	80	160	180	100	70	240	190	50	12	14	505	268	340	57
														72			
														79			
CM 32/250	C	B	A	100	180	225	125	95	320	250	65	14	14	625	305	405	102
														106			
														136			
CM 40/125	C	B	A	80	112	140	100	70	210	160	50	12	14	495	220	252	42
																	44
																	48
CM 40/160	B	A	A	80	132	160	100	70	240	190	50	12	14	500	245	292	52
																	57
																	75
CM 40/200	B	A	A	100	160	180	100	70	265	212	50	15	14	590	273	340	81
																	75
																	81
CM 40/250	B	A	A	100	180	225	125	95	320	250	65	15	14	630	322	405	101
														700			
														135			
CM 50/125	B	A	A	100	132	160	100	70	240	190	50	12	14	525	250	292	54
																	58
																	75
CM 50/160	B	A	A	100	160	180	100	70	265	212	50	12	14	590	270	340	81
																	75
																	81
CM 50/200	C	B	A	100	160	200	100	70	265	212	50	12	14	635	290	360	90
																	103
																	133
CM 50/250	C	B	A	100	180	225	125	95	320	250	65	14	14	705	332	405	139
																	154
																	164
CM 65/125	B	A	A	100	160	180	125	95	280	212	65	14	14	605	280	340	77
																	83
																	100
CM 65/160	C	B	A	100	160	200	125	95	280	212	65	14	14	635	290	360	104
																	104
																	135
CM 65/200	C	B	A	100	180	225	125	95	320	250	65	14	14	705	330	405	139
																	153
																	164
CM 65/250	B	A	A	100	200	250	160	120	360	280	80	16	19	750	330	405	204
																	226
																	226
CM 80/160	D	C	B	A	125	180	225	125	95	320	250	14	14	665	330	405	114
														735			
														143			
CM 80/200	B	A	A	125	180	225	125	95	345	280	65	16	14	780	355	405	158
														168			
														200			
CM 100/160	B	A	A	125	200	280	160	120	360	280	80	18	18	870	390	480	222
														208			
CM 100/160	A																231

SURFACE MOUNTED PUMPS

CM 32

E

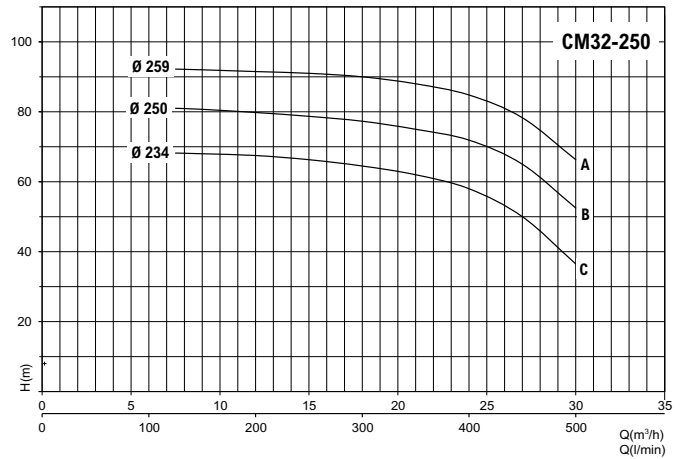
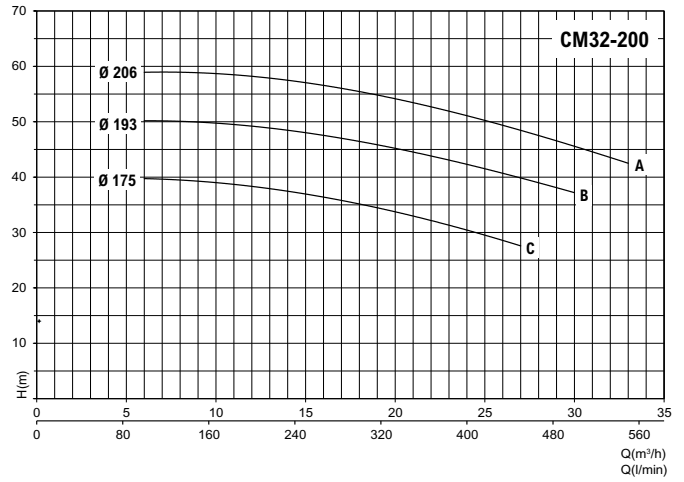
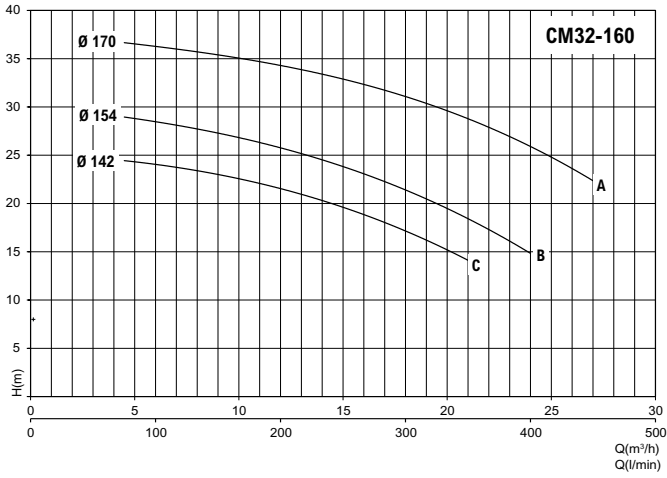

MODEL	MOTOR POWER		VOLTAGE	AMP 3 x 400 V	CODE
	HP	Kw			
CM 32/160 C	2	1.5	3 ~ 230 ÷ 400 V	3.6	573-2KKK
CM 32/160 B	3	2.2	3 ~ 230 ÷ 400 V	4.9	573-3KKK
CM 32/160 A	4	3	3 ~ 230 ÷ 400 V	6.8	573-4KKK
CM 32/200 C	5.5	4	3 ~ 230 ÷ 400 V	8.9	573-5KKK
CM 32/200 B	7.5	5.5	3 ~ 400 ÷ 690 V	11.1	573-7KKK
CM 32/200 A	10	7.5	3 ~ 400 ÷ 690 V	14.1	573-9KKK
CM 32/250 C	12.5	9.2	3 ~ 400 ÷ 690 V	16.8	574-0KKK
CM 32/250 B	15	11	3 ~ 400 ÷ 690 V	20.0	574-1KKK
CM 32/250 A	20	15	3 ~ 400 ÷ 690 V	23.2	574-2KKK

SURFACE MOUNTED PUMPS

CM 40

E

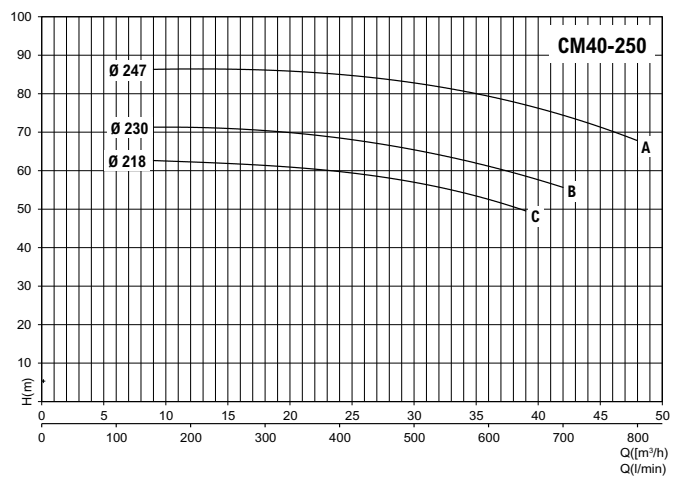
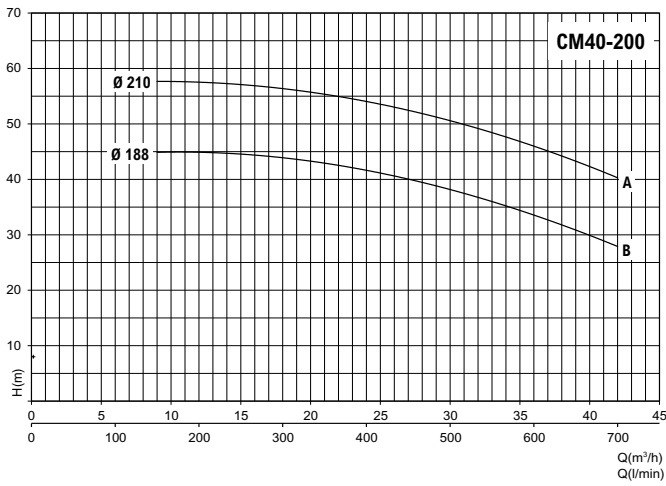
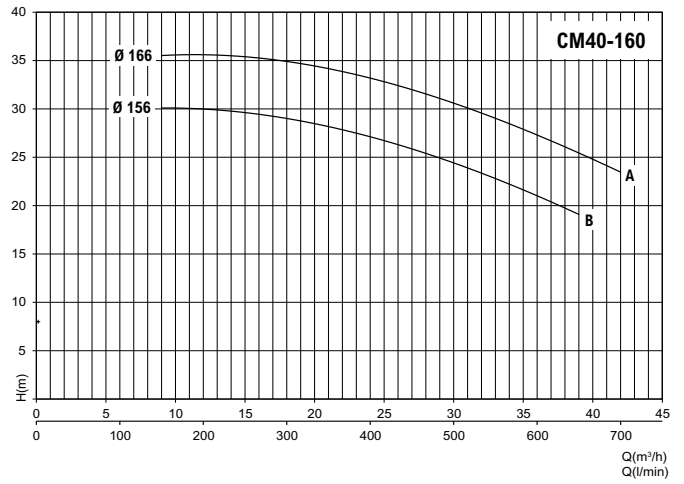
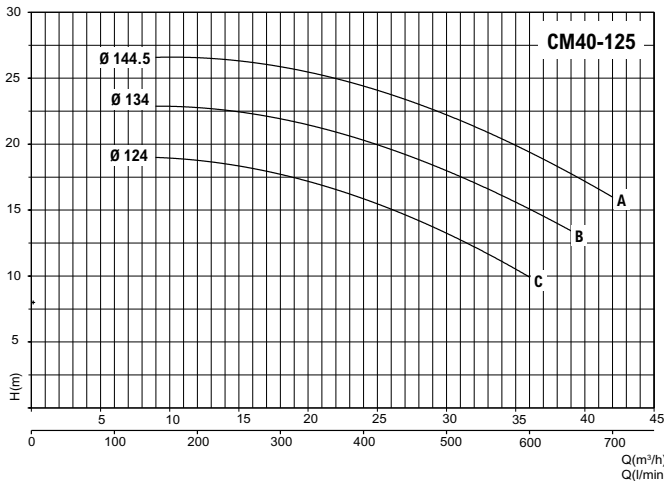

MODEL	MOTOR POWER		VOLTAGE	AMP 3 x 400 V	CODE
	HP	Kw			
CM 40/125 C	2	1.5	3 ~ 230 ÷ 400 V	3.6	577-0KKK
CM 40/125 B	3	2.2	3 ~ 230 ÷ 400 V	4.9	577-1KKK
CM 40/125 A	4	3	3 ~ 230 ÷ 400 V	6.5	577-2KKK
CM 40/160 B	4	3	3 ~ 230 ÷ 400 V	6.8	574-4KKK
CM 40/160 A	5.5	4	3 ~ 230 ÷ 400 V	8.8	574-5KKK
CM 40/200 B	7.5	5.5	3 ~ 400 ÷ 690 V	11.4	574-6KKK
CM 40/200 A	10	7.5	3 ~ 400 ÷ 690 V	15.1	575-1KKK
CM 40/250 C	12.5	9.2	3 ~ 400 ÷ 690 V	18.0	576-7KKK
CM 40/250 B	15	11	3 ~ 400 ÷ 690 V	23.3	574-9KKK
CM 40/250 A	20	15	3 ~ 400 ÷ 690 V	29.1	575-0KKK

SURFACE MOUNTED PUMPS

CM 50

E

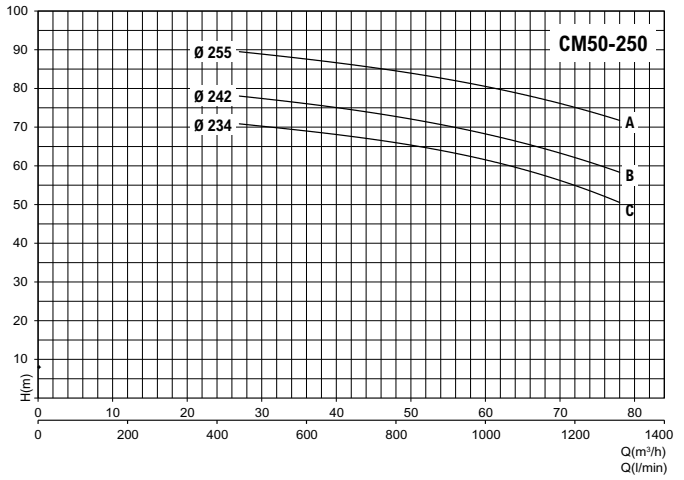
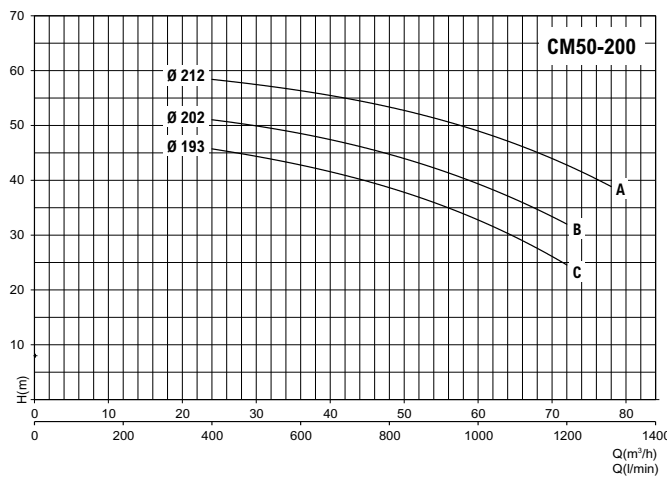
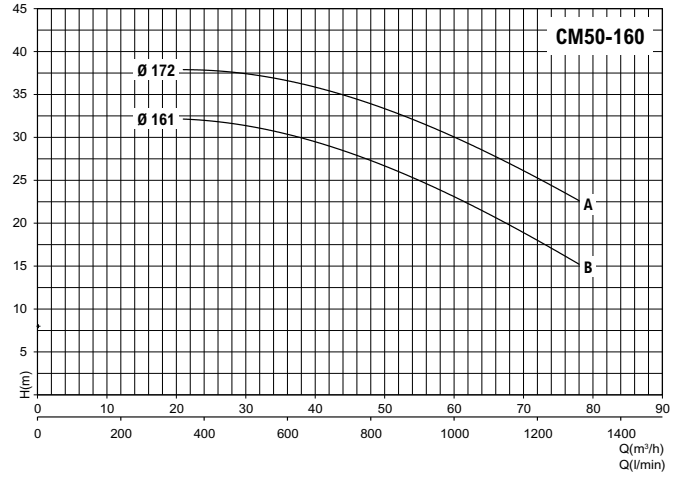
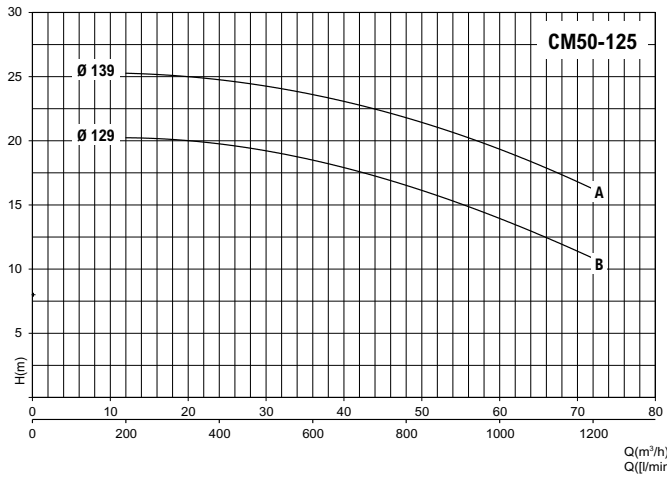

MODEL	MOTOR POWER		VOLTAGE	AMP 3 x 400 V	CODE
	HP	Kw			
CM 50/125 B	4	3	3 ~ 230 ÷ 400 V	6.8	577-3KKK
CM 50/125 A	5.5	4	3 ~ 230 ÷ 400 V	8.8	577-4KKK
CM 50/160 B	7.5	5.5	3 ~ 400 ÷ 690 V	10.9	575-3KKK
CM 50/160 A	10	7.5	3 ~ 400 ÷ 690 V	14.4	575-5KKK
CM 50/200 C	12.5	9.2	3 ~ 400 ÷ 690 V	17.2	577-5KKK
CM 50/200 B	15	11	3 ~ 400 ÷ 690 V	19.5	575-6KKK
CM 50/200 A	20	15	3 ~ 400 ÷ 690 V	24.7	575-7KKK
CM 50/250 C	20	15	3 ~ 400 ÷ 690 V	28.6	575-8KKK
CM 50/250 B	25	18.5	3 ~ 400 ÷ 690 V	34.3	575-9KKK
CM 50/250 A	30	22	3 ~ 400 ÷ 690 V	40.9	576-0KKK

SURFACE MOUNTED PUMPS

CM 65

E

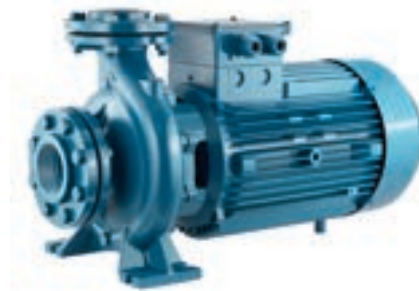
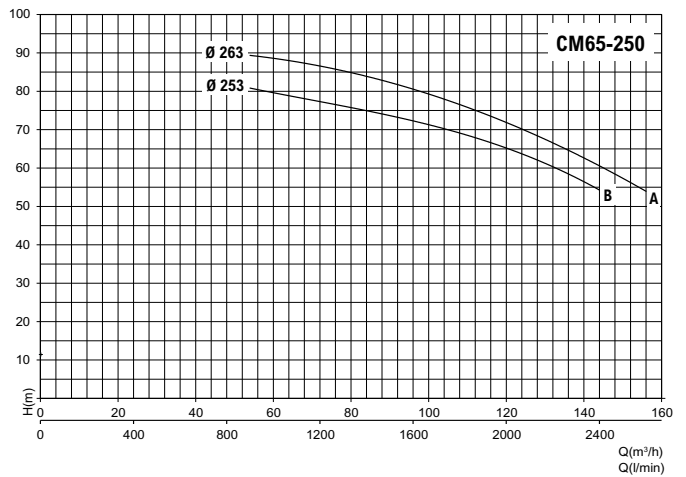
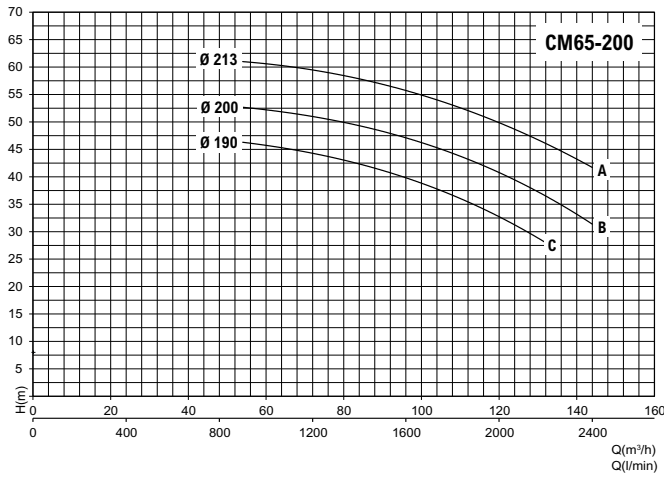
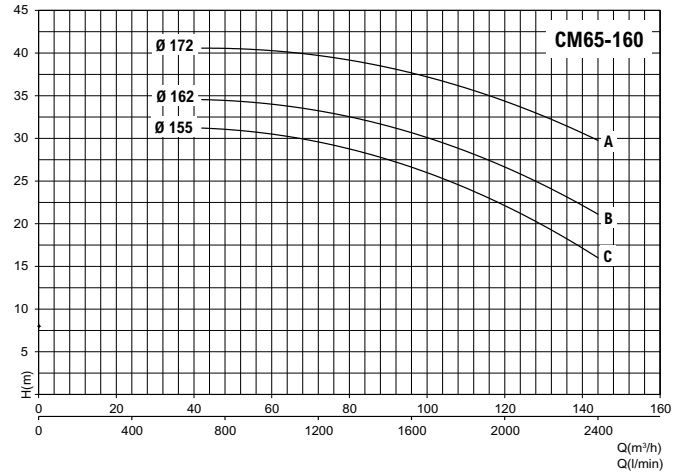
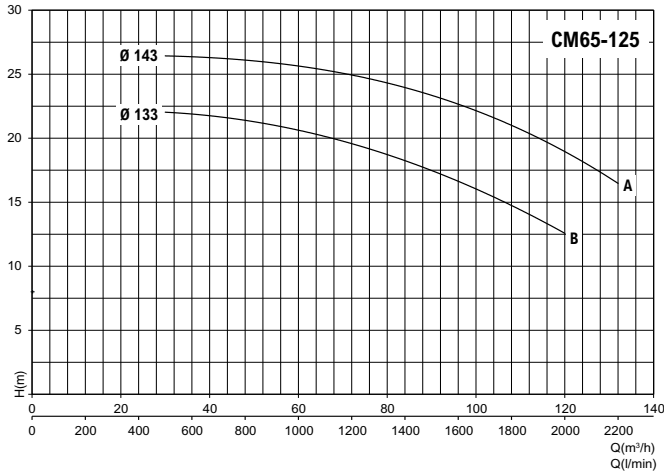

MODEL	MOTOR POWER		VOLTAGE	AMP 3 x 400 V	CODE
	HP	Kw			
CM 65/125 B	7.5	5.5	3 ~ 400 ÷ 690 V	11.0	577-6KKK
CM 65/125 A	10	7.5	3 ~ 400 ÷ 690 V	14.4	577-7KKK
CM 65/160 C	12.5	9	3 ~ 400 ÷ 690 V	16.8	576-1KKK
CM 65/160 B	15	11	3 ~ 400 ÷ 690 V	20.6	576-2KKK
CM 65/160 A	20	15	3 ~ 400 ÷ 690 V	28.5	576-3KKK
CM 65/200 C	20	15	3 ~ 400 ÷ 690 V	28.3	576-4KKK
CM 65/200 B	25	18.5	3 ~ 400 ÷ 690 V	34.8	576-5KKK
CM 65/200 A	30	22	3 ~ 400 ÷ 690 V	41.7	576-6KKK
CM 65/250 B	40	30	3 ~ 400 ÷ 690 V	55.3	577-8KKK
CM 65/250 A	50	37	3 ~ 400 ÷ 690 V	69.2	577-9KKK

SURFACE MOUNTED PUMPS

CM 80

E

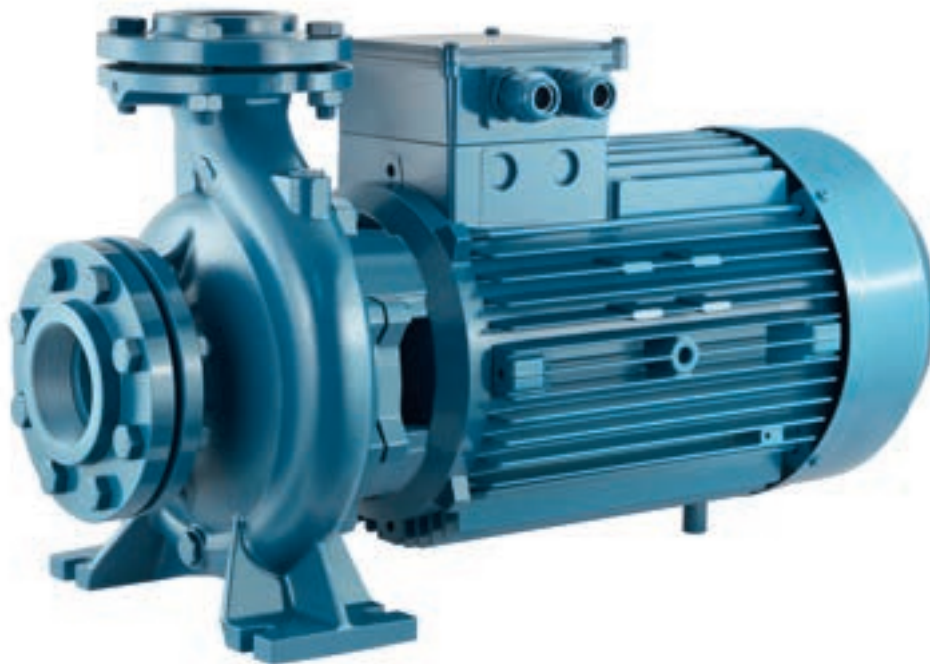
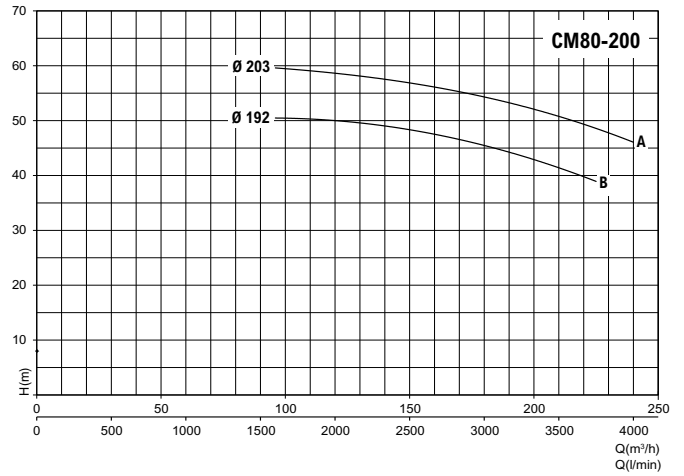
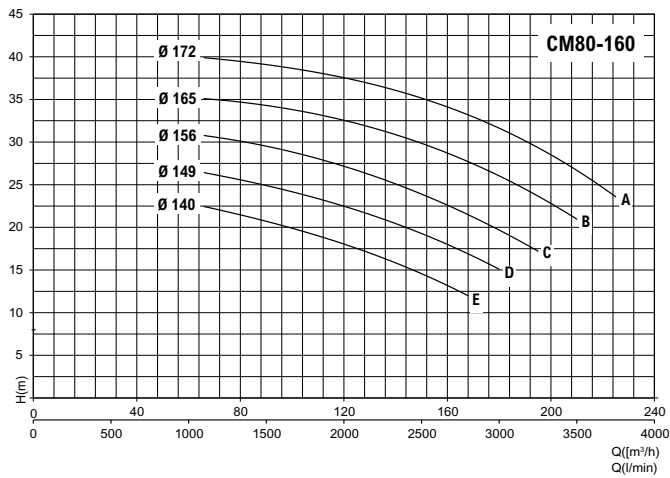

MODEL	MOTOR POWER		VOLTAGE	AMP 3 x 400 V	CODE
	HP	Kw			
CM 80/160 E	12.5	9.2	3 ~ 400 ÷ 690 V	16.3	578-4KKK
CM 80/160 D	15	11	3 ~ 400 ÷ 690 V	20.0	578-0KKK
CM 80/160 C	20	15	3 ~ 400 ÷ 690 V	24.5	578-1KKK
CM 80/160 B	25	18.5	3 ~ 400 ÷ 690 V	30.3	578-2KKK
CM 80/160 A	30	22	3 ~ 400 ÷ 690 V	37.0	578-3KKK
CM 80/200 B	40	30	3 ~ 400 ÷ 690 V	57.2	578-6KKK
CM 80/200 A	50	37	3 ~ 400 ÷ 690 V	71.6	578-7KKK

SURFACE MOUNTED PUMPS

CM 100

E

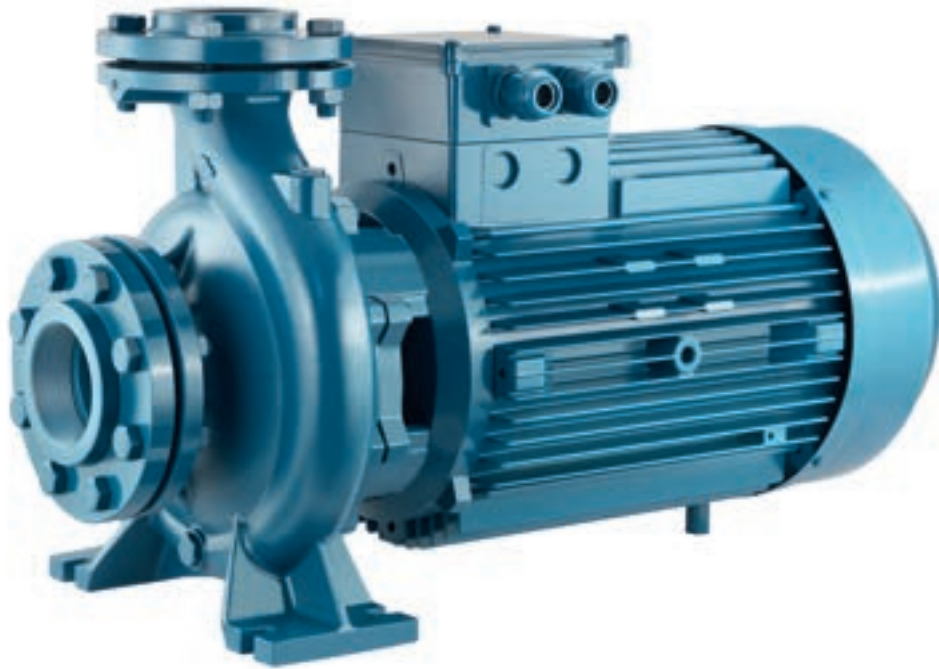
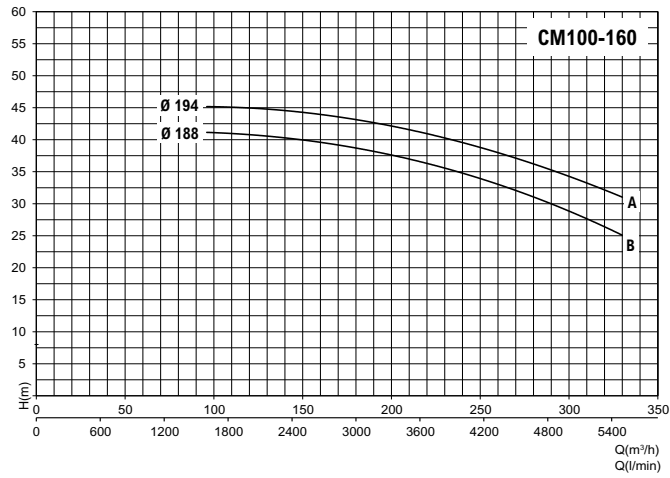

MODEL	MOTOR POWER		VOLTAGE	AMP 3 x 400v	CODE
	HP	Kw			
CM 100-160 B	40	30	400/690v	57.1	578-8KKK
CM 100-160 A	50	37	400/690v	70.2	578-9KKK

SURFACE MOUNTED PUMPS

PVM 3

Version With Oval Flanges
PVM 3-3 - 3-19

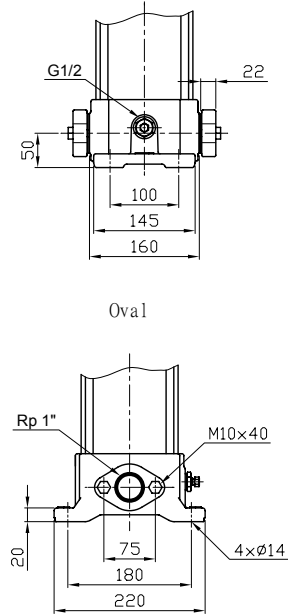

Version With Round Flanges
PVM 3-23 - 3-33 PN25 /
DN25/32

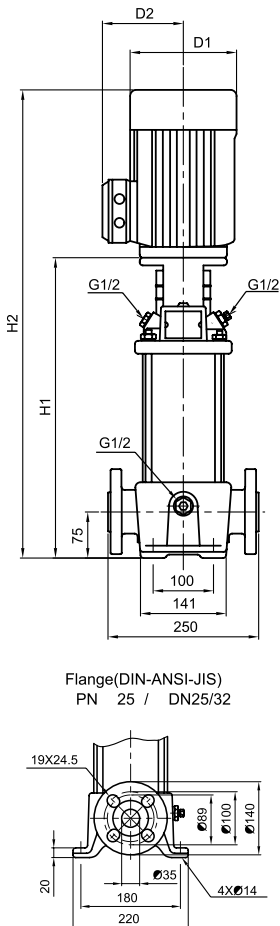

Flange(DIN-ANSI-JIS)
PN 25 / DN25/32

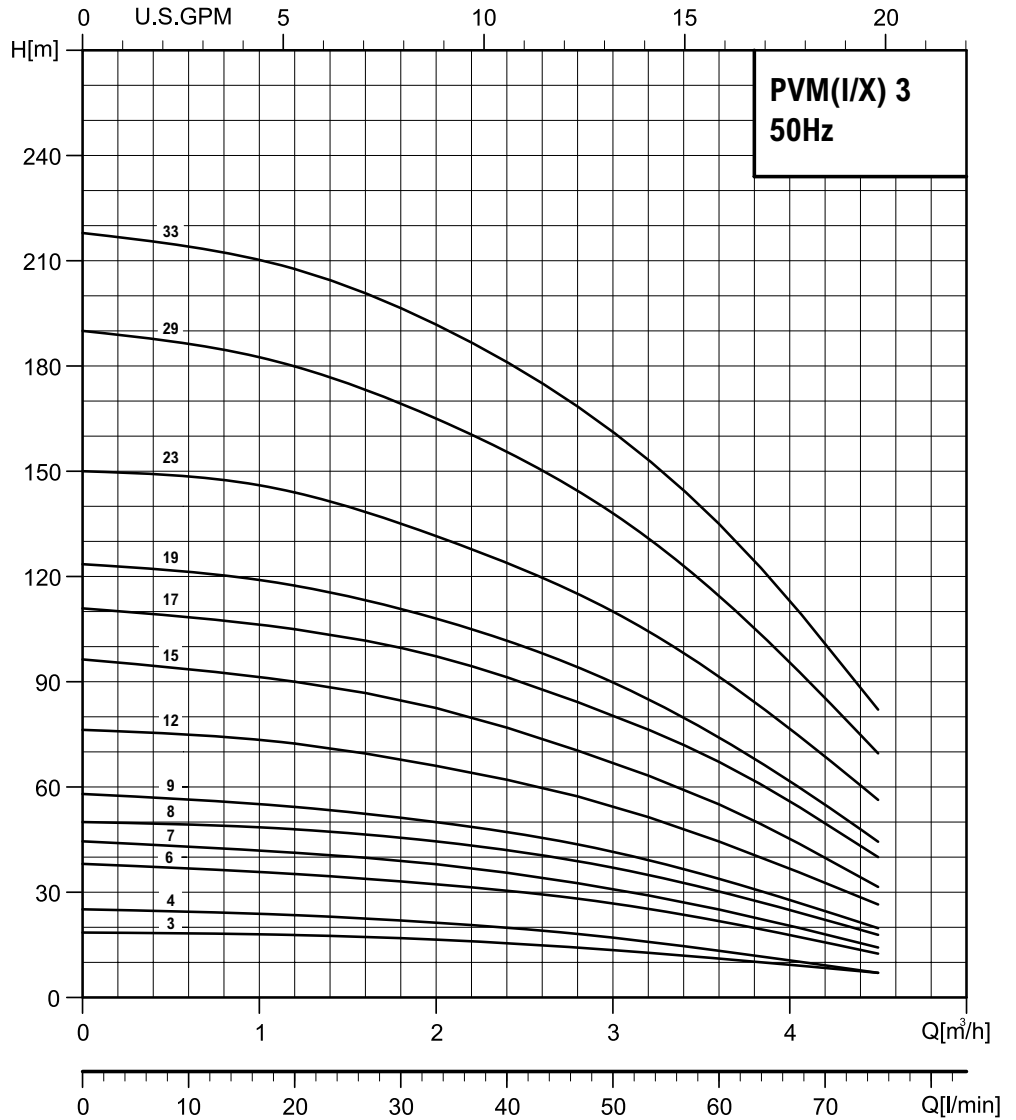

MODEL	DIMENSIONS APPROX (mm)			
	H1	H2	D1	D2
PVM 3-3 A (VLR 2B-30/2 A)	279	474	141	115
PVM 3-4 A (VLR 2B-30 A)	297	492	141	115
PVM 3-6 A (VLR 2B-40 A)	333	528	141	115
PVM 3-7 A (VLR 2B-50 A)	351	546	141	115
PVM 3-8 A (VLR 2B-60 A)	375	610	141	115
PVM 3-9 A (VLR 2B-70 A)	393	628	141	115
PVM 3-12 A (VLR 2B-90 A)	447	682	141	115
PVM 3-15 A (VLR 2B-110 A)	501	736	141	115
PVM 3-17 A (VLR 2B-130 A)	553	820	180	138
PVM 3-19 A (VLR 2B-150 A)	589	856	180	138
PVM 3-23 F (VLR 2B-180 F)	661	928	180	138
PVM 3-29 F (VLR 2B-220 F)	769	1036	180	138
PVM 3-33 F (VLR 2B-260 F)	845	1166	194	145

SURFACE MOUNTED PUMPS

PENTAIR NOCCHI PVM 3 VERTICAL MULTISTAGE

E

The PVM 3's are vertical multistage centrifugal pumps with "in line" suction and delivery points directly connected to an electric motor. They are not self-priming. Design Features include: Impellers, diffusers and outer pump chamber in AISI 304 stainless steel, shaft in AISI 316L stainless steel. Base and head casting are cast iron. Tungsten carbide mechanical seal. EPDM O rings. All 'A' versions are complete with 1" oval counterflanges. All 'F' versions are DN25/32 round flanges, counterflanges are available upon request. WRAS Approved

Features

Tungsten Carbide Seal
Stainless Impellers & Diffusers
3 m³/h

Applications

Boosting
Water Supply



PVM-A



PVM-F

MODEL	VOLTAGE	INLET/OUTLET	LM/HM	Kw	AMP	Kg	CODE
PVM 3-3 AM (VLR 2B-30/2 AM)	230v	1" x 1"	70/21	0.37	2.8	23.4	2000-1006
PVM 3-3 AT (VLR 2B-30/2 AT)	400v	1" x 1"	70/21	0.37	1.1	23.4	2000-1008
PVM 3-4 AM (VLR 2B-30 AM)	230v	1" x 1"	70/30	0.37	2.8	23.8	2000-1010
PVM 3-4 AT (VLR 2B-30 AT)	400v	1" x 1"	70/30	0.37	1.1	23.8	2000-1012
PVM 3-6 AM (VLR 2B-40 AM)	230v	1" x 1"	70/41	0.55	4.2	25.0	2000-1018
PVM 3-6 AT (VLR 2B-40 AT)	400v	1" x 1"	70/41	0.55	1.6	25.0	2000-1020
PVM 3-7 AM (VLR 2B-50 AM)	230v	1" x 1"	70/45	0.55	4.2	25.4	2000-1022
PVM 3-7 AT (VLR 2B-50 AT)	400v	1" x 1"	70/45	0.55	1.6	25.4	2000-1024
PVM 3-8 AM (VLR 2B-60 AM)	230v	1" x 1"	70/50	0.75	5.0	27.9	2000-1026
PVM 3-8 AT (VLR 2B-60 AT)	400v	1" x 1"	70/50	0.75	2.1	27.9	2000-1028
PVM 3-9 AM (VLR 2B-70 AM)	230v	1" x 1"	70/58	0.75	5.0	28.3	2000-1030
PVM 3-9 AT (VLR 2B-70 AT)	400v	1" x 1"	70/58	0.75	2.1	28.3	2000-1032
PVM 3-12 AM (VLR 2B-90 AM)	230v	1" x 1"	70/76	1.1	7.9	30.5	2000-1042
PVM 3-12 AT (VLR 2B-90 AT)	400v	1" x 1"	70/76	1.1	3.0	30.5	2000-1044
PVM 3-15 AM (VLR 2B-110 AM)	230v	1" x 1"	70/96	1.1	7.9	31.6	2000-1048
PVM 3-15 AT (VLR 2B-110 AT)	400v	1" x 1"	70/96	1.1	3.0	31.6	2000-1050
PVM 3-17 AM (VLR 2B-130 AM)	230v	1" x 1"	70/110	1.5	10.5	41.0	2000-1052
PVM 3-17 AT (VLR 2B-130 AT)	400v	1" x 1"	70/110	1.5	3.0	41.0	2000-1054
PVM 3-19 AM (VLR 2B-150 AM)	230v	1" x 1"	70/122	1.5	10.5	41.8	2000-1056
PVM 3-19 AT (VLR 2B-150 AT)	400v	1" x 1"	70/122	1.5	3.0	41.8	2000-1058
PVM 3-23 AT (VLR 2B-180 FT)	400v	DN25/32	70/150	2.2	4.6	46.1	2000-1064
PVM 3-29 FT (VLR 2B-220 FT)	400v	DN25/32	70/190	2.2	4.6	48.3	2000-1070
PVM 3-33 FT (VLR 2B-260 FT)	400v	DN25/32	70/217	3.0	5.6	57.4	2000-1074

SURFACE MOUNTED PUMPS

PVM 5

Version With Oval Flanges
PVM 5-3 - 5-20

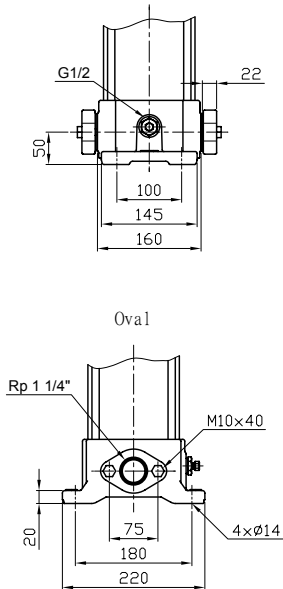

Version With Round Flanges
PVM 5-24 - 5-36 PN25 /
DN25/32

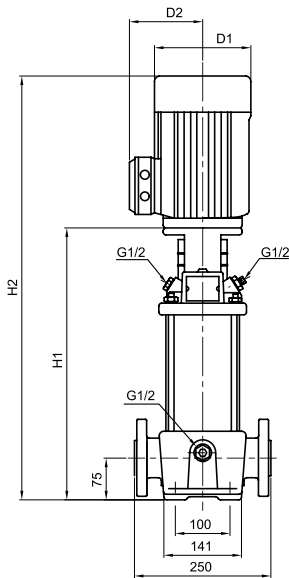

Flange(DIN-ANSI-JIS)
PN 25 / DN25/32

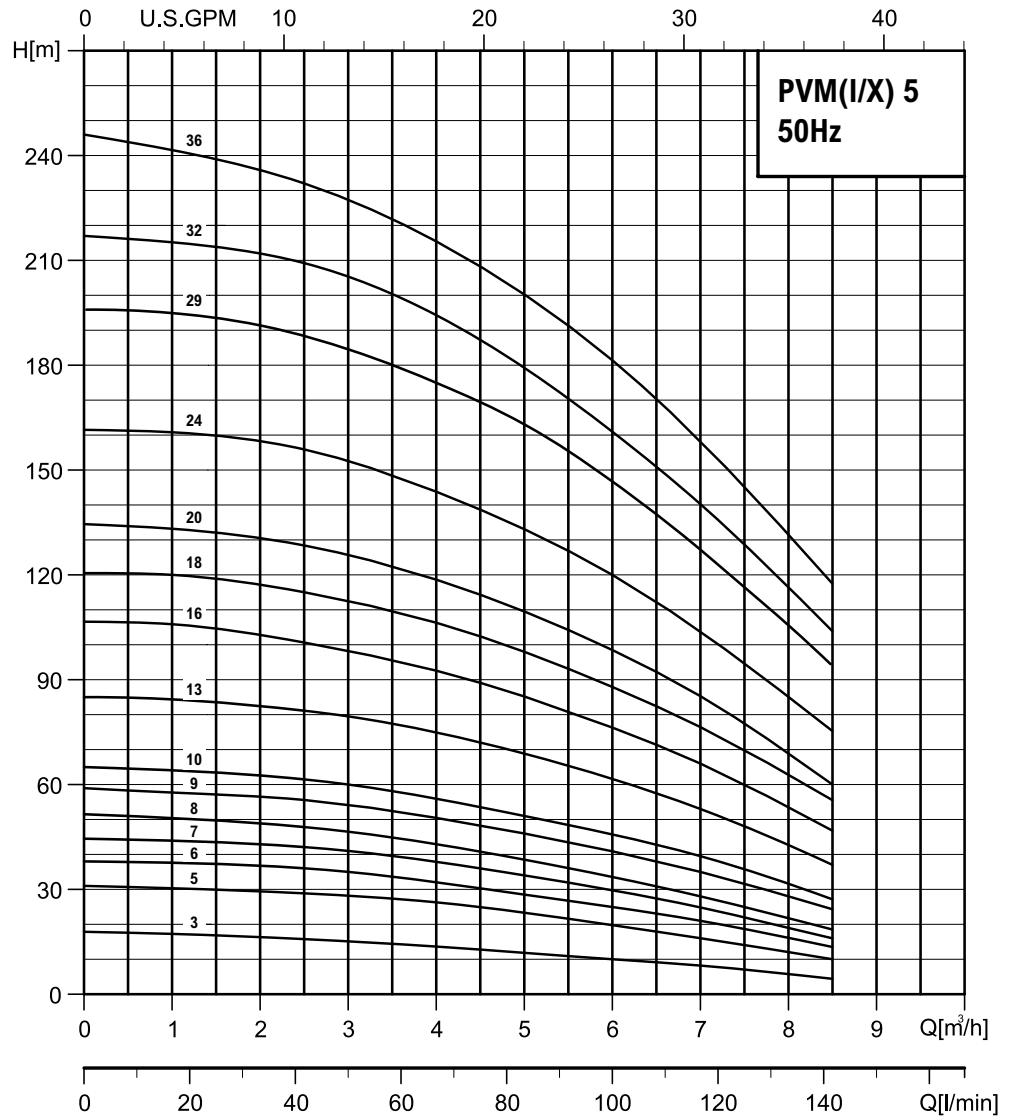
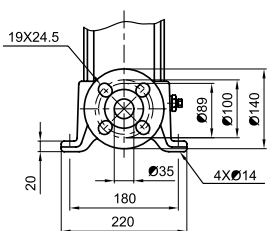

MODEL	DIMENSIONS APPROX (mm)			
	H1	H2	D1	D2
PVM 5-3 AM (VLR4-20 AM)	306	501	141	115
PVM 5-5 AM (VLR4-30 AM)	366	601	141	115
PVM 5-6 AM (VLR4-40 AM)	393	628	141	115
PVM 5-7 AM (VLR4-50 AM)	420	655	141	115
PVM 5-8 AM (VLR4-60 AM)	447	682	141	115
PVM 5-9 AM (VLR4-80/7 AM)	490	757	180	138
PVM 5-10 AM (VLR4-80 AM)	517	784	180	138
PVM 5-13 AT (VLR4-100 AT)	598	865	180	138
PVM 5-16 AT (VLR4-120 AT)	679	946	180	138
PVM 5-18 AT (VLR4-140 AT)	737	1058	194	145
PVM 5-20 AT (VLR4-160 AT)	791	1112	194	145
PVM 5-24 FT (VLR4-220 FT)	899	1227	225	160
PVM 5-32 FT (VLR4-240 FT)	1145	1510	248	194
PVM 5-36 FT (VLR4-260 FT)	1253	1618	248	194

SURFACE MOUNTED PUMPS

PENTAIR NOCCHI PVM 5 VERTICAL MULTISTAGE

E

The PVM 5's are vertical multistage centrifugal pumps with "in line" suction and delivery points directly connected to an electric motor. They are not self-priming. Design Features include: Impellers, diffusers and outer pump chamber in AISI 304 stainless steel, shaft in AISI 316L stainless steel. Base and head casting are cast iron. Tungsten carbide mechanical seal. EPDM O rings. All 'A' versions are complete with 1 1/4" oval counterflanges. All 'F' versions are DN25/32 round flanges, counterflanges are available upon request. WRAS Approved.

Features

Tungsten Carbide Seal
Stainless Impellers & Diffusers
5 m³/h

Applications

Boosting
Water Supply



PVM-A



PVM-F

MODEL	VOLTAGE	INLET/OUTLET	LM/HM	Kw	AMP	Kg	CODE
PVM 5-3 AM (VLR4-20 AM)	230v	1 1/4" x 1 1/4"	140/21	0.55	4.2	24.2	2000-1106
PVM 5-3 AT (VLR4-20 AT)	400v	1 1/4" x 1 1/4"	140/21	0.55	1.6	24.2	2000-1108
PVM 5-5 AM (VLR4-30 AM)	230v	1 1/4" x 1 1/4"	140/30	0.75	5.0	27.4	2000-1114
PVM 5-5 AT (VLR4-30 AT)	400v	1 1/4" x 1 1/4"	140/30	0.75	2.1	27.4	2000-1116
PVM 5-6 AM (VLR4-40 AM)	230v	1 1/4" x 1 1/4"	140/38	1.1	7.9	29.1	2000-1118
PVM 5-6 AT (VLR4-40 AT)	400v	1 1/4" x 1 1/4"	140/38	1.1	3	29.1	2000-1120
PVM 5-7 AM (VLR4-50 AM)	230v	1 1/4" x 1 1/4"	140/45	1.1	7.9	29.6	2000-1122
PVM 5-7 AT (VLR4-50 AT)	400v	1 1/4" x 1 1/4"	140/45	1.1	3.0	29.6	2000-1124
PVM 5-8 AM (VLR4-60 AM)	230v	1 1/4" x 1 1/4"	140/51	1.1	7.9	30.1	2000-1126
PVM 5-8 AT (VLR4-60 AT)	400v	1 1/4" x 1 1/4"	140/51	1.1	3.0	30.1	2000-1128
PVM 5-9 AM (VLR4-80/7 AM)	230v	1 1/4" x 1 1/4"	140/59	1.5	10.5	39.3	2000-1130
PVM 5-9 AT (VLR4-80/7 AT)	400v	1 1/4" x 1 1/4"	140/59	1.5	3	39.3	2000-1132
PVM 5-10 AM (VLR4-80 AM)	230v	1 1/4" x 1 1/4"	140/65	1.5	10.5	39.9	2000-1134
PVM 5-10 AT (VLR4-80 AT)	400v	1 1/4" x 1 1/4"	140/65	1.5	3.0	39.9	2000-1136
PVM 5-13 AT (VLR4-100 AT)	400v	1 1/4" x 1 1/4"	140/85	2.2	4.6	44.2	2000-1146
PVM 5-16 AT (VLR4-120 AT)	400v	1 1/4" x 1 1/4"	140/106	2.2	4.6	45.8	2000-1152
PVM 5-18 AT (VLR4-140 AT)	400v	1 1/4" x 1 1/4"	140/120	3.0	5.6	54.3	2000-1154
PVM 5-20 AT (VLR4-160 AT)	400v	1 1/4" x 1 1/4"	140/134	3.0	5.6	55.5	2000-1156
PVM 5-24 FT (VLR4-190 FT)	400v	DN25/32	140/160	4.0	7.0	57.8	2000-1160
PVM 5-29 FT (VLR4-220 FT)	400v	DN25/32	140/195	4.0	7.0	60.6	2000-1164
PVM 5-32 FT (VLR4-240 FT)	400/690v	DN25/32	140/216	5.5	10/5.8	90.1	2000-1166
PVM 5-36 FT (VLR4-260 FT)	400/690v	DN25/32	140/245	5.5	13.1/7.6	92.6	2000-1168

SURFACE MOUNTED PUMPS

PVM 10

Version With Oval Flanges
PVM 10-2 - 10-12

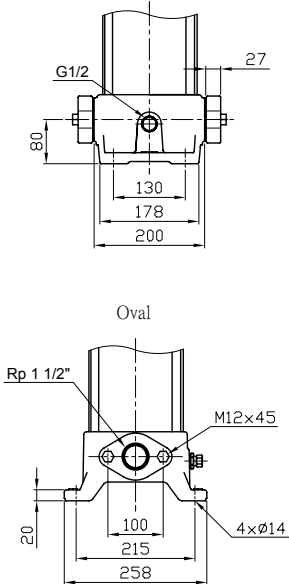

Version With Round Flanges
PVM 10-14 - 10-20 PN16-25 / DN40

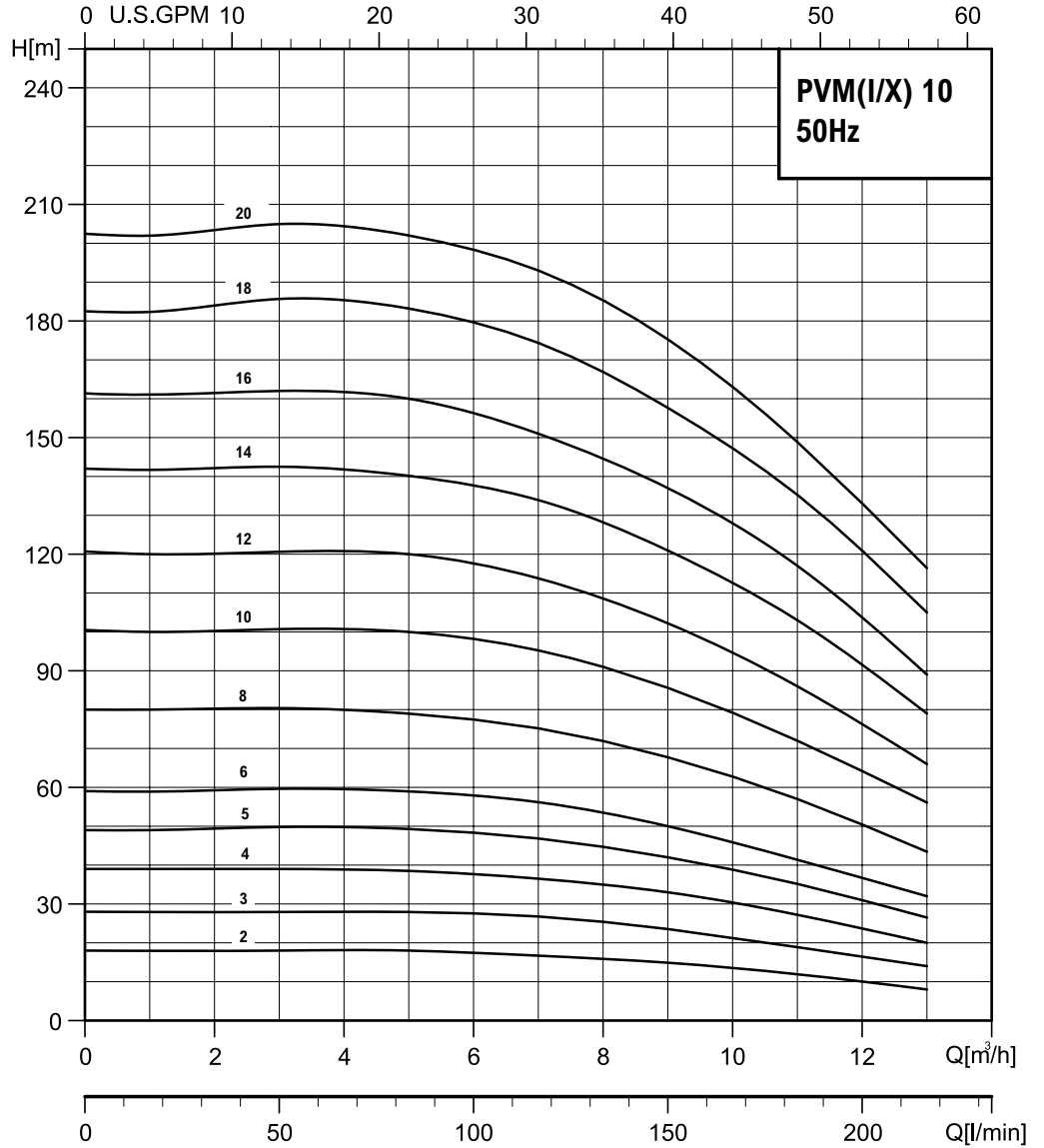
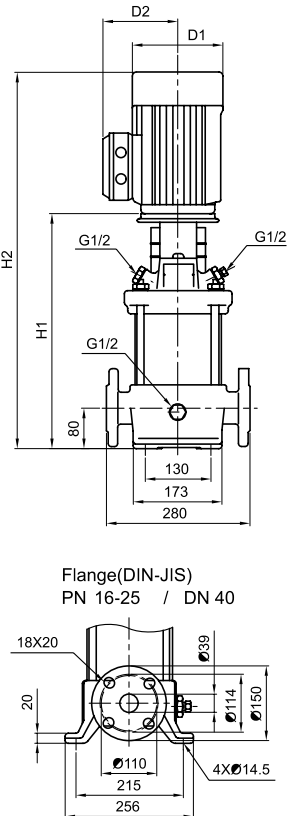

MODEL	DIMENSIONS APPROX (mm)			
	H1	H2	D1	D2
PVM 10-2 AM (VLR 8-20 AM)	347	582	141	115
PVM 10-3 AM (VLR 8-30 AM)	377	612	141	115
PVM 10-4 AM (VLR 8-40 AM)	423	690	180	138
PVM 10-5 AT (VLR 8-50 AT)	453	720	180	138
PVM 10-6 AT (VLR 8-60 AT)	483	750	180	138
PVM 10-8 AT (VLR 8-80 AT)	548	869	194	145
PVM 10-10 AT (VLR 8-100 AT)	608	936	225	160
PVM 10-12 AT (VLR 8-120 AT)	668	996	225	160
PVM 10-14 FT (VLR 8-140 FT)	760	1125	248	194
PVM 10-16 FT (VLR 8-160 FT)	820	1185	248	194
PVM 10-18 FT (VLR 8-180 FT)	880	1265	248	194
PVM 10-20 AT (VLR 8-200 FT)	940	1325	248	194

SURFACE MOUNTED PUMPS

PENTAIR NOCCHI PVM 10 VERTICAL MULTISTAGE

E

The PVM 10's are vertical multistage centrifugal pumps with "in line" suction and delivery points directly connected to an electric motor. They are not self-priming. Design Features include: Impellers, diffusers and outer pump chamber in AISI 304 stainless steel, shaft in AISI 316L stainless steel. Base and head casting are cast iron. Tungsten carbide mechanical seal. EPDM O rings. All 'A' versions are complete with 1½" oval counterflanges. All 'F' versions are DN40 round flanges, counterflanges are available upon request WRAS Approved.

Features

Tungsten Carbide Seal
Stainless Impellers & Diffusers
10 m³/h

Applications

Boosting
Water Supply



PVM-A



PVM-F



MODEL	VOLTAGE	INLET/OUTLET	LM/HM	Kw	AMP	Kg	CODE
PVM 10-2 AM (VLR 8-20 AM)	230v	1½" x 1½"	215/18	0.75	5.0	38.2	2000-1204
PVM 10-2 AT (VLR 8-20 AT)	400v	1½" x 1½"	215/18	0.75	2.1	38.2	2000-1206
PVM 10-3 AM (VLR 8-30 AM)	230v	1½" x 1½"	215/28	1.1	7.9	40.3	2000-1208
PVM 10-3 AT (VLR 8-30 AT)	400v	1½" x 1½"	215/28	1.1	3.0	40.3	2000-1210
PVM 10-4 AM (VLR 8-40 AM)	230v	1½" x 1½"	215/38	1.5	10.5	50.1	2000-1212
PVM 10-4 AT (VLR 8-40 AT)	400v	1½" x 1½"	215/38	1.5	3	50.1	2000-1214
PVM 10-5 AT (VLR 8-50 AT)	400v	1½" x 1½"	215/49	2.2	4.6	53.9	2000-1216
PVM 10-6 AT (VLR 8-60 AT)	400v	1½" x 1½"	215/58	2.2	4.6	55.0	2000-1218
PVM 10-8 AT (VLR 8-80 AT)	400v	1½" x 1½"	215/80	3.0	5.6	64.9	2000-1222
PVM 10-10 AT (VLR 8-100 AT)	400v	1½" x 1½"	215/100	4.0	7.0	70.3	2000-1226
PVM 10-12 AT (VLR 8-120 AT)	400v	1½" x 1½"	215/120	4.0	7.0	72.4	2000-1228
PVM 10-14 FT (VLR 8-140 FT)	400/690v	DN40	215/141	5.5	10/5.8	104.1	2000-1230
PVM 10-16 FT (VLR 8-160 FT)	400/690v	DN40	215/161	5.5	10/5.8	106.2	2000-1232
PVM 10-18 FT (VLR 8-180 FT)	400/690v	DN40	215/181	7.5	13.1/7.6	113.6	2000-1234
PVM 10-20 AT (VLR 8-200 FT)	400/690v	DN40	215/201	7.5	13.1/7.6	116.7	2000-1236

SURFACE MOUNTED PUMPS

PVM 15

Version With Round Flanges
PVM 15

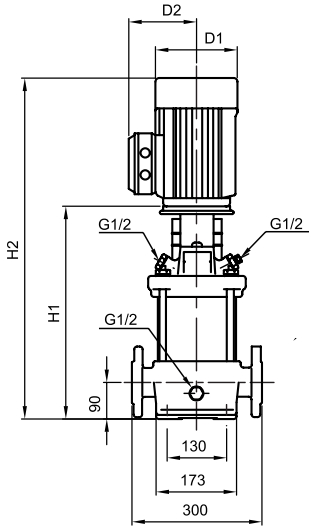

Flange(DIN)
PN 16-25 / DN 50

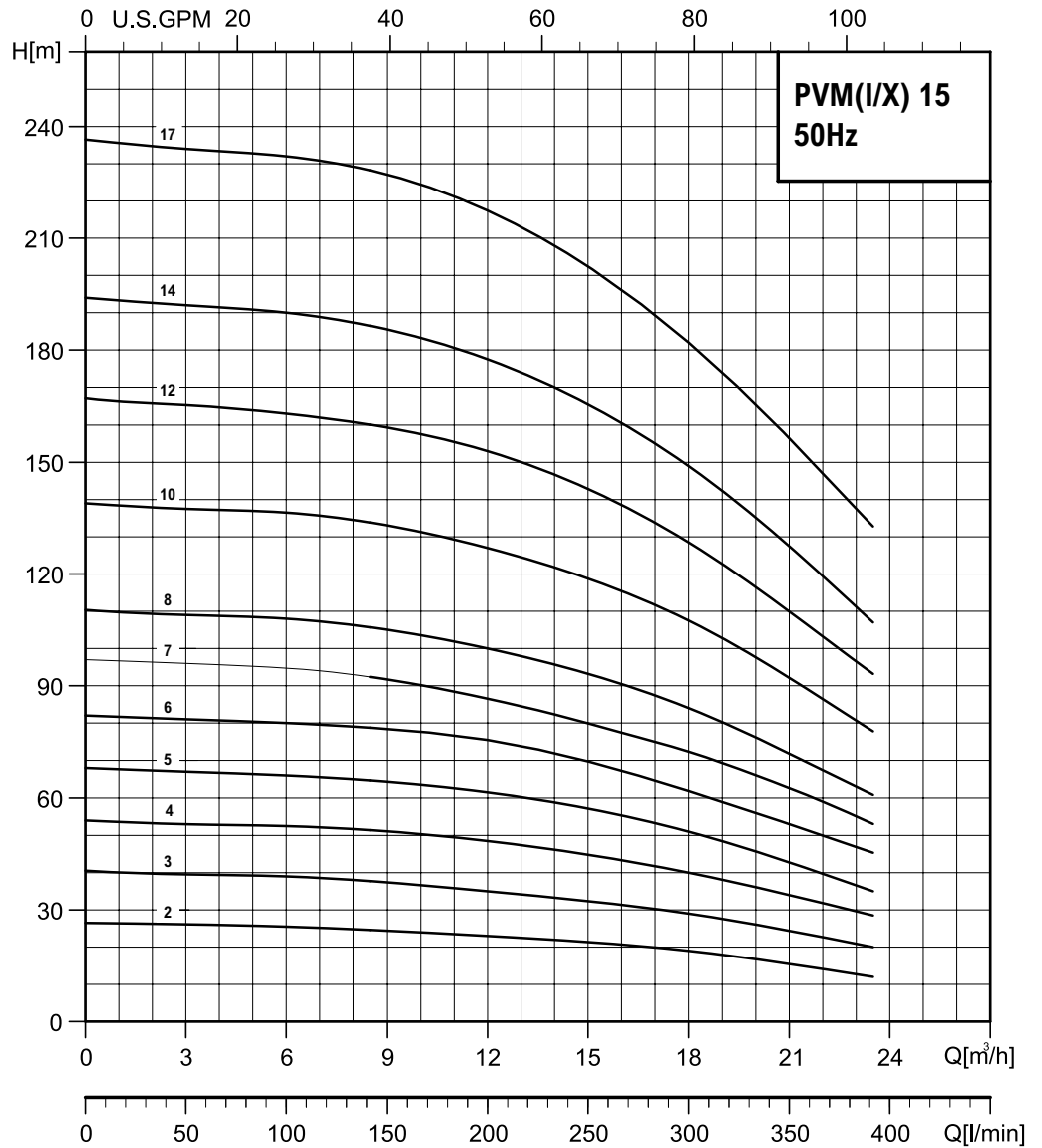
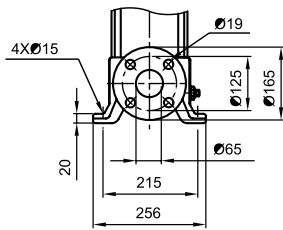

MODEL	DIMENSIONS APPROX (mm)			
	H1	H2	D1	D2
PVM 15-2 FT (VLR 16-30/2 FT)	415	682	180	138
PVM 15-3 FT (VLR 16-30 FT)	465	786	194	145
PVM 15-4 FT (VLR 16-40 FT)	510	838	225	160
PVM 15-5 FT (VLR 16-50 FT)	555	883	225	160
PVM 15-6 FT (VLR 16-60 FT)	632	997	248	194
PVM 15-7 FT (VLR 16-70 FT)	677	1042	248	194
PVM 15-8 FT (VLR 16-80 FT)	722	1107	248	194
PVM 15-10 FT (VLR 16-100 FT)	889	1387	317	238
PVM 15-12 FT (VLR 16-120 FT)	979	1477	317	238
PVM 15-14 FT (VLR 16-140 FT)	1069	1567	317	238
PVM 15-17 FT (VLR 16-160 FT)	1204	1702	317	238

SURFACE MOUNTED PUMPS

PENTAIR NOCCHI PVM 15 VERTICAL MULTISTAGE

E

The PVM 15's are vertical multistage centrifugal pumps with "in line" suction and delivery points directly connected to an electric motor. They are not self-priming. Design Features include: Impellers, diffusers and outer pump chamber in AISI 304 stainless steel, shaft in AISI 316L stainless steel. Base and head casting are cast iron. Tungsten carbide mechanical seal. EPDM O rings. All 'F' versions are DN50 round flanges, counterflanges are available upon request.

Features

Tungsten Carbide Seal
Stainless Impellers & Diffusers
15 m³/h

Applications

Boosting
Water Supply



PVM-F

MODEL	VOLTAGE	INLET/OUTLET	LM/HM	Kw	AMP	Kg	CODE
PVM 15-2 FT (VLR 16-30/2 FT)	400v	DN50	390/28	2.2	4.6	55.7	2000-1252
PVM 15-3 FT (VLR 16-30 FT)	400v	DN50	390/40	3.0	5.6	64.9	2000-1254
PVM 15-4 FT (VLR 16-40 FT)	400v	DN50	390/53	4.0	7.0	69.7	2000-1256
PVM 15-5 FT (VLR 16-50 FT)	400v	DN50	390/68	4.0	7.0	71.2	2000-1258
PVM 15-6 FT (VLR 16-60 FT)	400/690v	DN50	390/81	5.5	10/5.8	102.3	2000-1260
PVM 15-7 FT (VLR 16-70 FT)	400/690v	DN50	390/97	5.5	10/5.8	103.8	2000-1262
PVM 15-8 FT (VLR 16-80 FT)	400/690v	DN50	390/110	7.5	13.1/7.6	111.8	2000-1264
PVM 15-10 FT (VLR 16-100 FT)	400/690v	DN50	390/139	11	19.7/11.4	150.0	2000-1268
PVM 15-12 FT (VLR 16-120 FT)	400/690v	DN50	390/166	11	19.7/11.4	153.0	2000-1270
PVM 15-14 FT (VLR 16-140 FT)	400/690v	DN50	390/193	11	19.7/11.4	156.3	2000-1272
PVM 15-17 FT (VLR 16-160 FT)	400/690v	DN50	390/236	15	26.7/15.5	171.5	2000-1274

SURFACE MOUNTED PUMPS

PVM 20

Version With Round Flanges
PVM 20

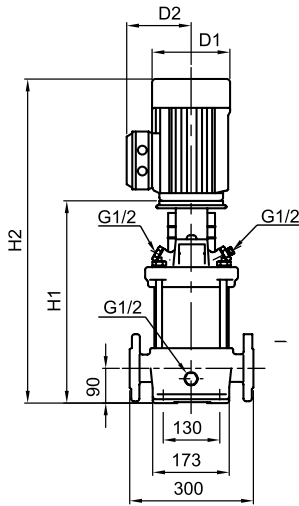

Flange(DIN)
PN 16-25 / DN 50

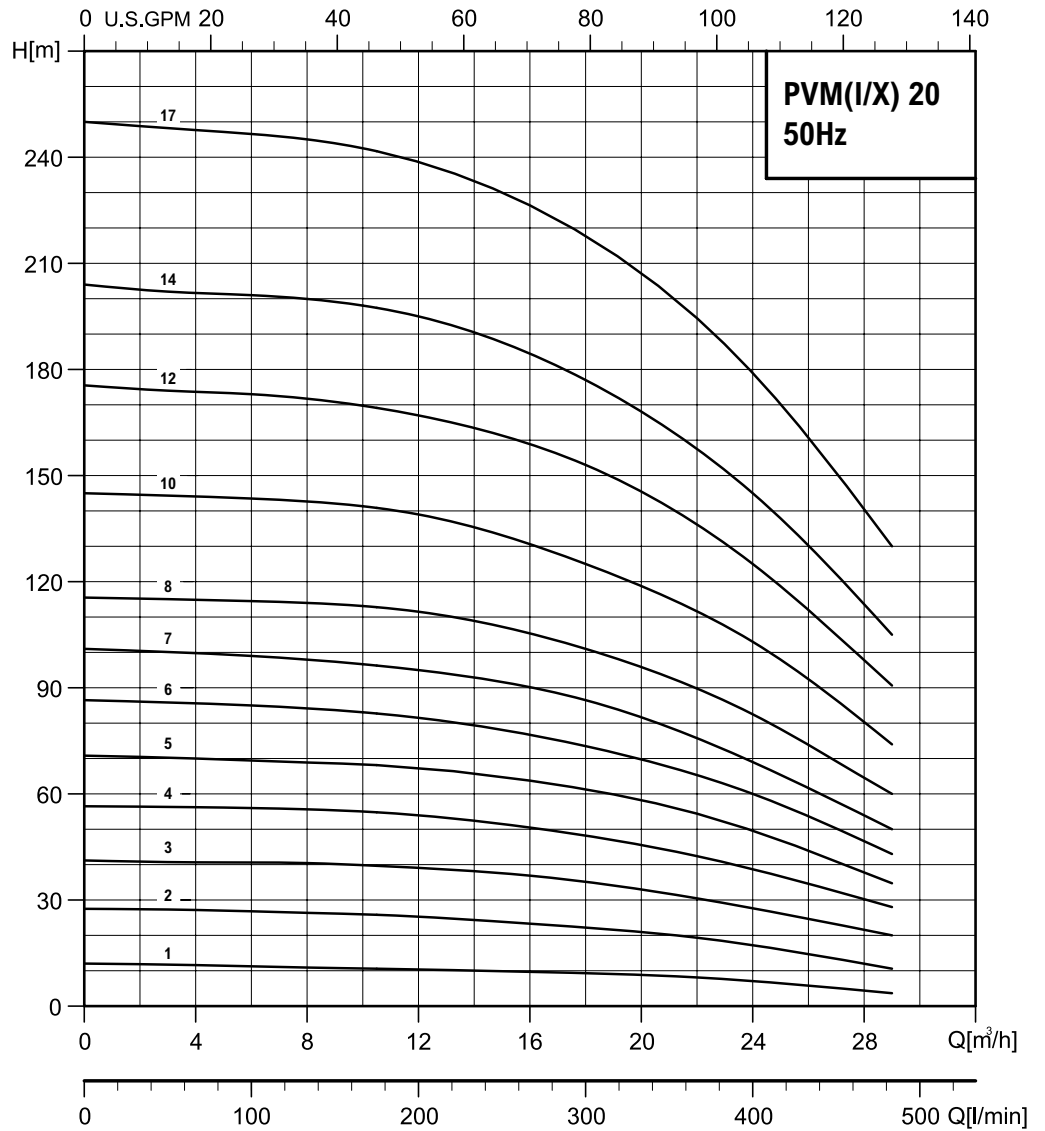
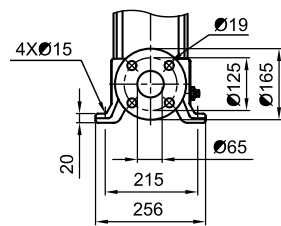

MODEL	DIMENSIONS APPROX (mm)			
	H1	H2	D1	D2
PVM 20-1	400	636	141	115
PVM 20-2	415	682	180	138
PVM 20-3	465	793	225	160
PVM 20-4	542	907	248	194
PVM 20-5	587	952	248	194
PVM 20-6	632	1017	248	194
PVM 20-7	677	1062	248	238
PVM 20-8	799	1297	317	238
PVM 20-10	889	1387	317	238
PVM 20-12	979	1477	317	238
PVM 20-14	1069	1567	317	238
PVM 20-17	1204	1746	317	238

SURFACE MOUNTED PUMPS

PENTAIR NOCCHI PVM 20 VERTICAL MULTISTAGE

E

The PVM 20's are vertical multistage centrifugal pumps with "in line" suction and delivery points directly connected to an electric motor. They are not self-priming. Design Features include: Impellers, diffusers and outer pump chamber in AISI 304 stainless steel, shaft in AISI 316L stainless steel. Base and head casting are cast iron. Tungsten carbide mechanical seal. EPDM O rings. All 'F' versions are DN50 round flanges, counterflanges are available upon request.

Features

Tungsten Carbide Seal
Stainless Impellers & Diffusers
20 m³/h

Applications

Boosting
Water Supply



PVM-F

MODEL	VOLTAGE	INLET/OUTLET	LM/HM	Kw	AMP	Kg	CODE
PVM 20-1 FT	400v	DN50	480/12	1.1	3.0	43.9	2000-1302
PVM 20-2 FT	400v	DN50	480/28	2.2	4.6	55.7	2000-1304
PVM 20-3 FT	400v	DN50	480/40	4.0	7.0	68.3	2000-1306
PVM 20-4 FT	400/690v	DN50	480/58	5.5	10/5.8	99.4	2000-1308
PVM 20-5 FT	400/690v	DN50	480/70	5.5	10/5.8	100.8	2000-1310
PVM 20-6 FT	400/690v	DN50	480/86	7.5	13.1/7.6	108.6	2000-1312
PVM 20-7 FT	400/690v	DN50	480/100	7.5	13.1/7.6	110.1	2000-1314
PVM 20-8 FT	400/690v	DN50	480/115	11	19.7/11.4	147.1	2000-1316
PVM 20-10 FT	400/690v	DN50	480/145	11	19.7/11.4	150.0	2000-1318
PVM 20-12 FT	400/690v	DN50	480/175	15	26.7/15.5	163.1	2000-1320
PVM 20-14 FT	400/690v	DN50	480/204	15	26.7/15.5	166.0	2000-1322
PVM 20-17 FT	400/690v	DN50	480/250	18.5	33/19.1	195.4	2000-1324

SURFACE MOUNTED PUMPS

PVM 32

Version With Round Flanges
PVM 32

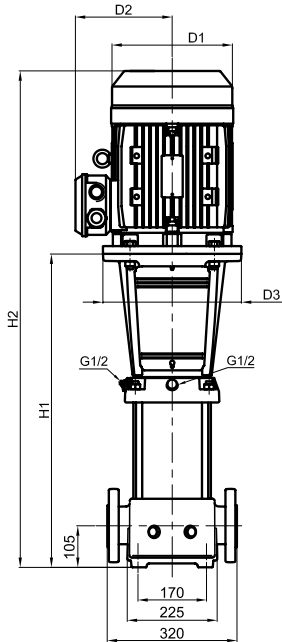

PN16-25-40 / DN65

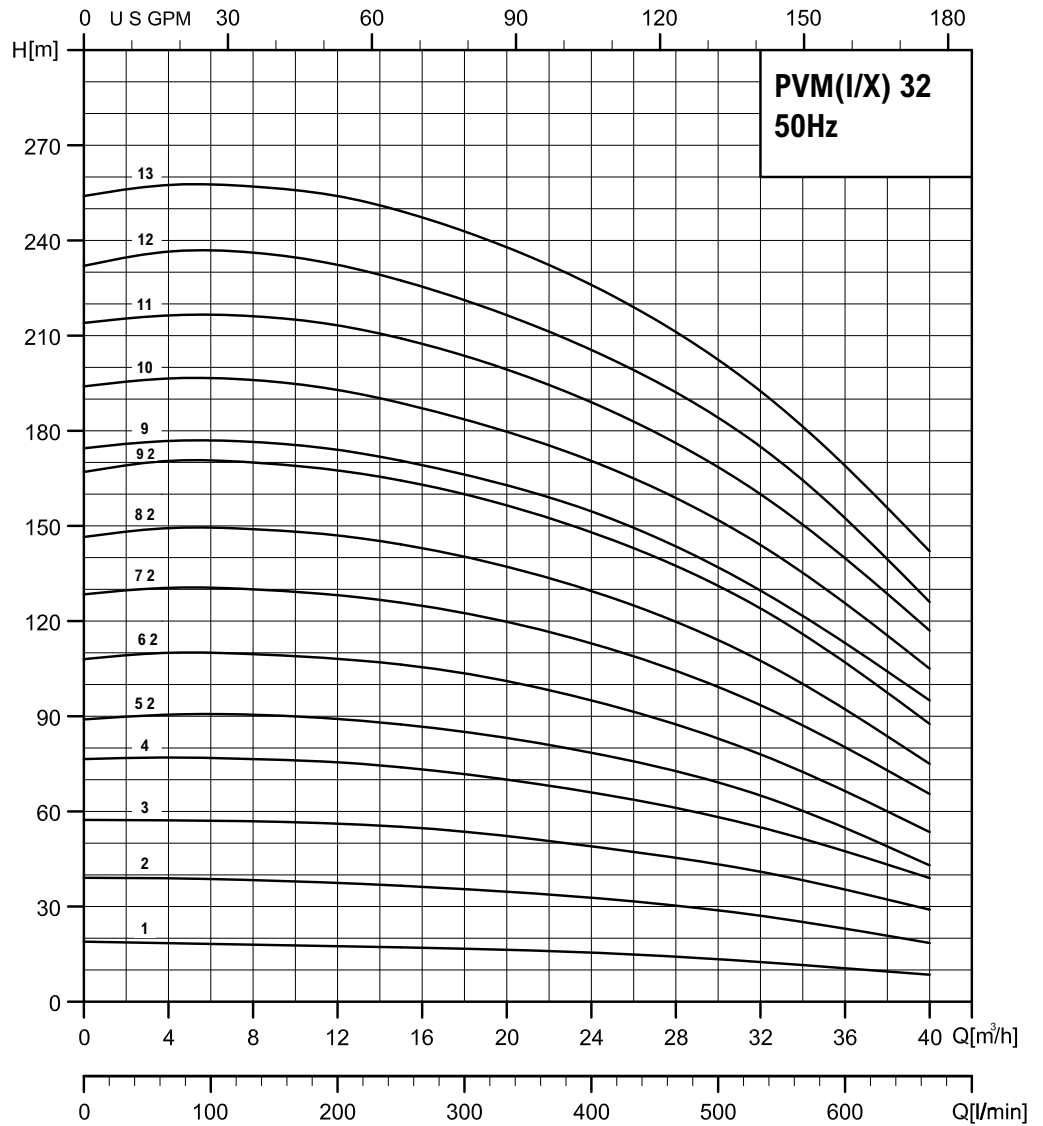
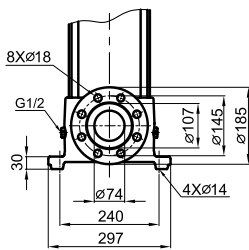

MODEL	DIMENSIONS APPROX (mm)			
	H1	H2	D1	D2
PVM 32-1 F (VLR 32-10)	504	771	180	138
PVM 32-2 F (VLR 32-20)	574	902	225	160
PVM 32-3 F (VLR 32-30)	644	1009	248	194
PVM 32-4 F (VLR 32-40)	714	1099	248	194
PVM 32-5-2 F (VLR 32-50)	894	1392	317	238
PVM 32-6-2 F (VLR 32-60)	964	1462	317	238
PVM 32-7-2 F (VLR 32-70)	1034	1532	317	238
PVM 32-8-2 F (VLR 32-80)	1104	1602	317	238
PVM 32-9-2 F (VLR 32-90)	1174	1716	317	238
PVM 32-9 F (VLR 32-100)	1174	1716	317	238
PVM 32-10 F (VLR 32-110)	1244	1786	317	238
PVM 32-11 F (VLR 32-120)	1314	1894	358	265
PVM 32-12 F (VLR 32-130)	1384	1964	358	265
PVM 32-13-2 F (VLR 32-140)	1454	2114	420	295

SURFACE MOUNTED PUMPS

PENTAIR NOCCHI PVM 32 VERTICAL MULTISTAGE

E

The PVM 32's are vertical multistage centrifugal pumps with "in line" suction and delivery points directly connected to an electric motor. They are not self-priming. Design Features include: Impellers, diffusers and outer pump chamber in AISI 304 stainless steel, shaft in AISI 316L stainless steel. Base and head casting are cast iron. Tungsten carbide mechanical seal. EPDM O rings. All 'F' versions are DN65 round flanges, counterflanges are available upon request.

Features

Tungsten Carbide Seal
Stainless Impellers & Diffusers
32 m³/h

Applications

Boosting
Water Supply



PVM-F

MODEL	VOLTAGE	INLET/OUTLET	LM/HM	Kw	AMP	Kg	CODE
PVM 32-1 FT (VLR 32-10)	400v	DN65	660/19	2.2	4.6	74.3	2000-1404
PVM 32-2 FT (VLR 32-20)	400v	DN65	660/39	4.0	7.0	87.6	2000-1408
PVM 32-3 FT (VLR 32-30)	400/690v	DN65	660/58	5.5	10/5.8	110.2	2000-1412
PVM 32-4 FT (VLR 32-40)	400/690v	DN65	660/77	7.5	13.1/7.6	119.5	2000-1416
PVM 32-5-2 FT (VLR 32-50)	400/690v	DN65	660/90	11	19.7/11.4	163.3	2000-1418
PVM 32-6-2 FT (VLR 32-60)	400/690v	DN65	660/110	11	19.7/11.4	166.3	2000-1422
PVM 32-7-2 FT (VLR 32-70)	400/690v	DN65	660/130	15	26.7/15.5	179.5	2000-1426
PVM 32-8-2 FT (VLR 32-80)	400/690v	DN65	660/149	15	26.7/15.5	182.6	2000-1430
PVM 32-9-2 FT (VLR 32-90)	400/690v	DN65	660/170	18.5	33/19.1	210.6	2000-1434
PVM 32-9 FT (VLR 32-100)	400/690v	DN65	660/174	18.5	33/19.1	210.6	2000-1436
PVM 32-10 FT (VLR 32-110)	400/690v	DN65	660/192	18.5	33/19.1	213.7	2000-1440
PVM 32-11 FT (VLR 32-120)	400/690v	DN65	660/214	22	40.8/23.7	258.8	2000-1444
PVM 32-12 FT (VLR 32-130)	400/690v	DN65	660/230	22	40.8/23.7	260.8	2000-1448
PVM 32-13-2 FT (VLR 32-140)	400/690v	DN65	660/245	30	52.8/30.6	328.2	2000-1450

SURFACE MOUNTED PUMPS

PVM 45

Version With Round Flanges
PVM 45

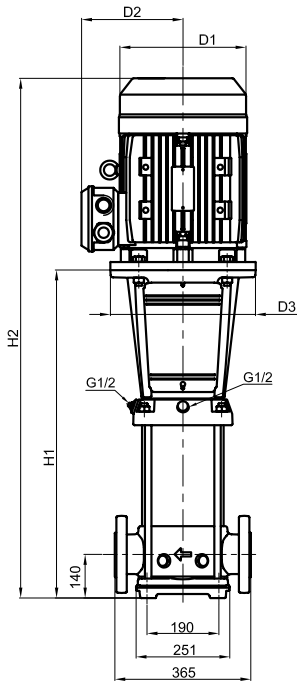

PN16-25-40 / DN80

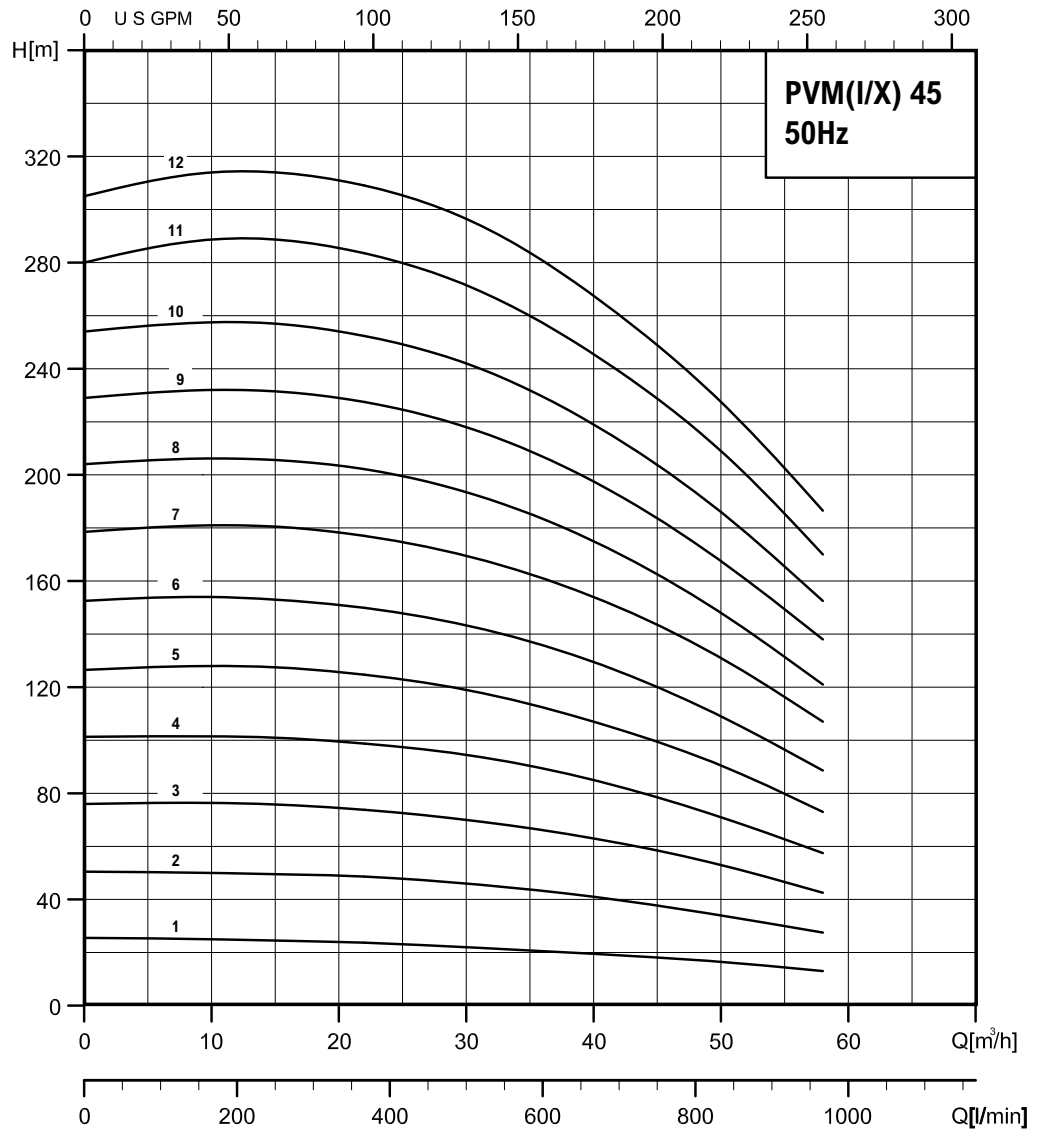
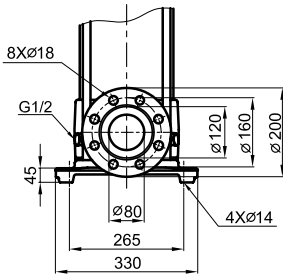

MODEL	H1	DIMENSIONS APPROX (mm)		
		H2	D1	D2
PVM 45-1 F (VLR 46-10)	560	889	160	145
PVM 45-2 F (VLR 46-20)	640	1026	248	194
PVM 45-3 F (VLR 46-30)	830	1329	317	238
PVM 45-4 F (VLR 46-40)	910	1409	317	238
PVM 45-5 F (VLR 46-50)	990	1533	317	238
PVM 45-6 F (VLR 46-60)	1070	1650	358	265
PVM 45-7 F (VLR 46-70)	1150	1810	420	295
PVM 45-8 F (VLR 46-80)	1230	1890	420	295
PVM 45-9 F (VLR 46-90)	1310	1970	420	295
PVM 45-10 F (VLR 46-100)	1390	2050	420	295
PVM 45-11 F (VLR 46-110)	1470	2160	470	325
PVM 45-12 F (VLR 46-120)	1550	2240	470	325

SURFACE MOUNTED PUMPS

PENTAIR NOCCHI PVM 45 VERTICAL MULTISTAGE

E

The PVM 45's are vertical multistage centrifugal pumps with "in line" suction and delivery points directly connected to an electric motor. They are not self-priming. Design Features include: Impellers, diffusers and outer pump chamber in AISI 304 stainless steel, shaft in AISI 316L stainless steel. Base and head casting are cast iron. Tungsten carbide mechanical seal. EPDM O rings. All 'F' versions are DN80 round flanges, counterflanges are available upon request. More models of PVM are available. PVM 64 up to 1400 L/M, PVM 90 up to 2000 L/M, PVM 120 up to 2600 L/M, PVM 150 up to 3000 L/M.

Features

Tungsten Carbide Seal
Stainless Impellers & Diffusers
45 m³/h

Applications

Boosting
Water Supply



PVM-F

MODEL	VOLTAGE	INLET/OUTLET	LM/HM	Kw	AMP	Kg	CODE
PVM 45-1 FT (VLR 46-10)	400v	DN80	1000/25	4.0	7.0	95.1	2000-1504
PVM 45-2 FT (VLR 46-20)	400/690v	DN80	1000/50	7.5	13.1/7.6	124.6	2000-1508
PVM 45-3 FT (VLR 46-30)	400/690v	DN80	1000/75	11	19.7/11.4	169.0	2000-1512
PVM 45-4 FT (VLR 46-40)	400/690v	DN80	1000/98	15	26.7/15.5	182.9	2000-1516
PVM 45-5 FT (VLR 46-50)	400/690v	DN80	1000/128	18.5	33.0/19.1	211.6	2000-1520
PVM 45-6 FT (VLR 46-60)	400/690v	DN80	1000/152	22	40.8/23.7	258.1	2000-1524
PVM 45-7 FT (VLR 46-70)	400/690v	DN80	1000/180	30	52.8/30.6	326.5	2000-1528
PVM 45-8 FT (VLR 46-80)	400/690v	DN80	1000/204	30	52.8/30.6	331.3	2000-1532
PVM 45-9 FT (VLR 46-90)	400/690v	DN80	1000/230	37	65.6/38	347.0	2000-1536
PVM 45-10 FT (VLR 46-100)	400/690v	DN80	1000/254	37	65.6/38	350.7	2000-1540
PVM 45-11 FT (VLR 46-110)	400/690v	DN80	1000/280	45	82.4/47.8	412.5	2000-1544
PVM 45-12 FT (VLR 46-120)	400/690v	DN80	1000/305	45	82.4/47.8	416.2	2000-1548

PRESSURE BOOSTING SYSTEMS ACCESSORIES

PRESSURE KIT ACCESSORIES

A

Flexible braided hoses come with one male thread for fitting into pump and one female thread to fit onto a pressure vessel. Maximum pressure 10 bar. R3V & R5V are multi way fittings for building booster sets where additional pressure switches, gauges can be added on.



TUBIFLEX	CONNECTION	LENGTH	Kg	CODE
1" x 500mm	1" MALE x 1" FEMALE	500mm	0.5	060-040
1" x 600mm	1" MALE x 1" FEMALE	600mm	0.56	060-042
1" x 700mm	1" MALE x 1" FEMALE	700mm	0.6	060-044
1" x 800mm	1" MALE x 1" FEMALE	800mm	0.75	060-046
1" x 1000mm	1" MALE x 1" FEMALE	1000mm	1	060-047
1¼" x 400mm	1¼" MALE x 1¼" FEMALE	400mm	0.75	060-048
2" x 500mm	2" MALE x 2" FEMALE	500mm	2	060-052
1" x 500mm ELBOW	1" MALE x 1" FEMALE ELBOW	500mm	0.5	060-055
1" x 600mm ELBOW	1" MALE x 1" FEMALE ELBOW	600mm	0.56	060-056
1" x 700mm ELBOW	1" MALE x 1" FEMALE ELBOW	700mm	0.6	060-058
1" x 1000mm ELBOW	1" MALE x 1" FEMALE ELBOW	1000mm	1	060-060
BRASS MULTIWAY	CONNECTION	LENGTH	Kg	CODE
R3V	1" MALE x 1" FEMALE x 1" FEMALE	70mm	0.19	060-010
R5V	1" MALE x 1" FEMALE x 1" FEMALE x ¼" MALE x ¼" FEMALE	80mm	0.21	060-012

PRESSURE BOOSTING SYSTEMS ACCESSORIES

PRESSURE SWITCHES AND GAUGES

A

Pressure switches for use with pump boosting pressure vessel systems. The switch ensures automatic control and the starting and stopping of the electric water pump according to the set pressure values. Electrical contacts. Rated at 10 amps maximum. Standard pressure gauges 1-6 bar and 1-10 bar, side or rear entry.

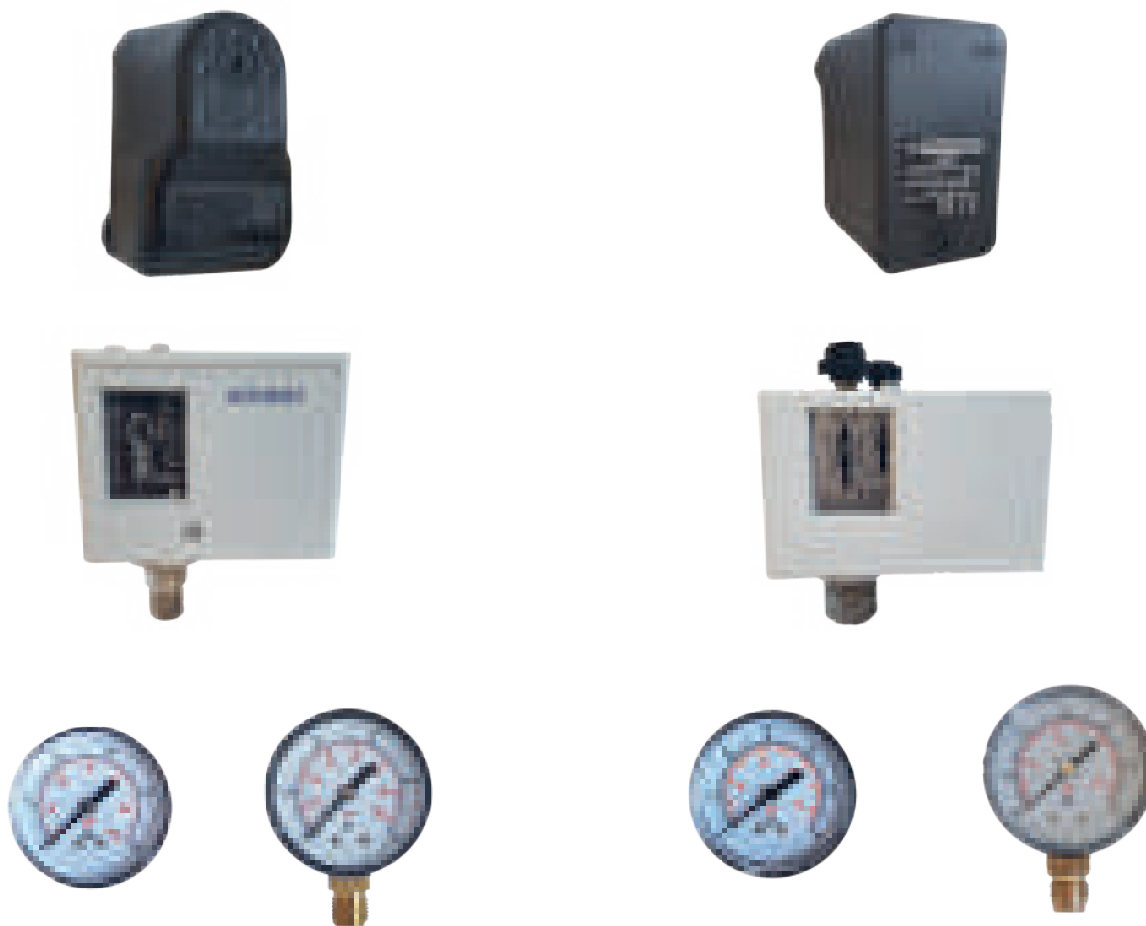

PRESSURE SWITCHES	CONNECTION	ADJUSTMENT	DIMENSIONS H x W x L mm	Kg	CODE
ITALTECNICA PP5 (PM5)	¼" FEMALE	1-5 BAR	104 x 61 x 100	0.37	060-400
ITALTECNICA PM12	¼" FEMALE	6-12 BAR	104 x 61 x 100	0.37	060-402
TELEMECANIQUE XM6	¼" FEMALE	1-6	98 x 57 x 108	0.43	060-410
TELEMECANIQUE XM12	¼" FEMALE	6-12	98 x 57 x 108	0.43	060-412
FANTINI B12CN	¼" FEMALE	0.2-9	83 x 88 x 48	0.36	060-414
FANTINI B12DN	¼" FEMALE	5-16	83 x 88 x 48	0.36	060-416
PEERLESS HLP506	¼" MALE	1-6	94 x 80 x 48	0.38	060-417
PRESSURE GAUGES	CONNECTION		SIZE	Kg	CODE
6 BAR REAR	¼" MALE		50mm	0.06	060-390
10 BAR REAR	¼" MALE		50mm	0.06	060-394
6 BAR SIDE	¼" MALE		50mm	0.06	060-392
10 BAR SIDE	¼" MALE		50mm	0.06	060-396

PRESSURE BOOSTING SYSTEMS ACCESSORIES

QUICKSTOP FLOW REGULATOR

E

Suitable for filling storage tanks or cisterns. The working mechanism and the jointed arm allows the opening and closing instantly by ensuring a high flow and avoiding dripping water. The Quickstop float in a lower position will remain constantly on, letting full flow into a tank or cistern. When the float arm reaches the off level it will completely shut off, no water, no drips. In combination with a water booster pump it will stop the rapid on and off (cycling, water hammer) where a pressure switch will think it has reached pressure but will quickly come on again due to a dripping float valve.

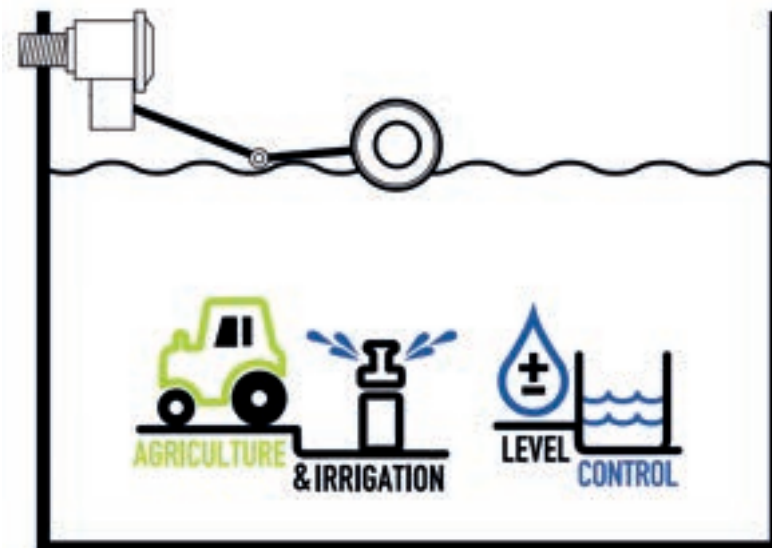

MODEL	CONNECTION	DIMENSIONS H x W x L mm	Kg	CODE
QUICKSTOP 3/4"	3/4"	80 x 50 x 240	0.385	060-850
QUICKSTOP 1"	1"	150 x 70 x 350	0.390	060-852
QUICKSTOP 1 1/4"	1 1/4"	150 x 70 x 350	0.415	060-854
QUICKSTOP 1 1/2"	1 1/2"	150 x 70 x 350	0.440	060-856

PRESSURE BOOSTING SYSTEMS ACCESSORIES

SWITCHMATIC PRESSURE SWITCH

A

SWITCHMATIC is an electronic pressure switch with an integrated digital pressure gauge. It can manage the start and stop of single-phase electric pumps up to 3 HP (2.2 Kw). Cut-in and cut-out pressure can be set easily and accurately through the user friendly control panel. Wiring is carried out identically to a conventional electromechanical switch. SWITCHMATIC can operate as a differential pressure switch, as an inverted pressure switch, or just with max or minimum pressures. SWITCHMATIC includes overcurrent, dry-running and fast cycling protection of the pump. 1-8 Bar.

Features

Dry Running Protection
Over Current Protection

Applications

Booster Sets

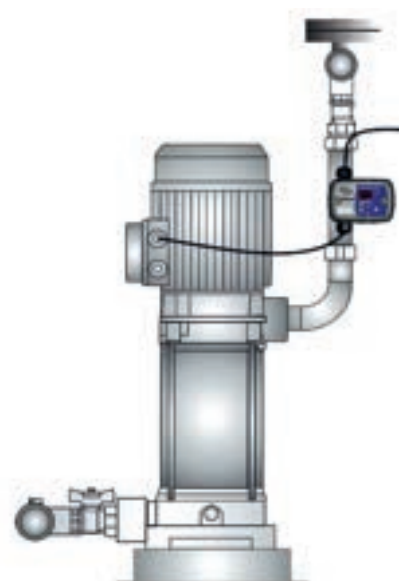

MODEL	VOLTAGE	CONNECTION	ADJUSTMENT	Kw	H x W x L mm	Kg	CODE
SWITCHMATIC 2	110/230v	¼" FEMALE	1-8 BAR	UP TO 2.2	100 x 50 x 116	0.28	9000-0100

PRESSURE BOOSTING SYSTEM ACCESSORIES

ELBI ACCUMULATOR PRESSURE VESSELS STAINLESS STEEL

E

Expansion vessels, also known as pressure vessels, are to provide a reserve of pressurised water to limit the number of on/off cycling of water booster pumps. Within the vessel is a membrane which on one side is pressurised air and the other side is water (inside the membrane). When the pump system is started and a valve is closed water is pushed into the membrane, reaching the set pressure by the pressure switch(es). The system then holds at pressure. When water is drawn the pressurised air forces the water out until the pressure falls below the set level of the pressure switch and the pump will then restart. All vessels are fitted with EPDM membranes.



MODEL	LITRES	STYLE	P MAX	AUX CON	MAIN CON	H x W x L mm	Kg	CODE
HX 2	2	NO MOUNT	10 BAR	–	½"	115 x 85 x ---	0.5	022-640
HM 8	8	NO MOUNT	10 BAR	–	¾"	350 x 210 x ---	2.3	022-641
HM 24	24	NO MOUNT	10 BAR	–	1"	520 x 280 x ---	4.8	022-642
HM 24 GPM	24	HORI	10 BAR	–	1"	310 x 280 x 520	5	022-644
HXV 50	50	VERT	10 BAR	–	1"	710 x 375 x ---	12	022-645
HXH 50	50	HORI	10 BAR	–	1"	400 x 375 x 570	12	022-647

REPLACEMENT MEMBRANES

MODEL	LITRES	CODE
AC 5-8	5/8	022-532
AC 25	24/25	022-534
AF 50	50	022-549
AF 60-100	60-100	022-536
AF 200	200	022-538
AF 300	300	022-540
AF 500	500	022-542
AF 500 16 BAR	500	022-543



PRESSURE BOOSTING SYSTEM ACCESSORIES

ELBI ACCUMULATOR PRESSURE VESSELS MILD STEEL

E

Expansion vessels, also known as pressure vessels, are to provide a reserve of pressurised water to limit the number of on/off cycling of water booster pumps. Within the vessel is a membrane which on one side is pressurised air and the other side is water (inside the membrane). When the pump system is started and a valve is closed water is pushed into the membrane, reaching the set pressure by the pressure switch(es). The system then holds at pressure. When water is drawn the pressurised air forces the water out until the pressure falls below the set level of the pressure switch and the pump will then restart. AC2 has butyl membrane. 5-500 have EPDM membranes. For replacement membranes see page 200. X models are WRAS approved.



MODEL	LITRES	STYLE	P MAX	AUX CON	MAIN CON	H x W x L mm	Kg	CODE
AC 2	2	NO MOUNT	8 BAR	–	¾"	230 x 130 x ---	0.5	022-550
AC 5	5	NO MOUNT	8 BAR	–	¾"	240 x 205 x ---	1.8	022-551
AC 8	8	NO MOUNT	8 BAR	–	¾"	315 x 204 x ---	2.3	022-552
AC 25X	25	NO MOUNT	8 BAR	–	1"	480 x 270 x ---	4.8	022-553
AC 25X GPM	25	HORI	8 BAR	–	1"	290 x 270 x 470	5.0	022-554
AFH 60X	60	HORI	8 BAR	½"F / ¾"M	1"	485 x 400 x 650	12.5	022-556
AFH 100X	100	HORI	8 BAR	½"F / ¾"M	1"	580 x 500 x 680	17.5	022-559
AFH 200X	200	HORI	8 BAR	½"F / ¾"M	1¼"	685 x 600 x 960	48.3	022-580
AFH 300X	300	HORI	8 BAR	½"F / ¾"M	1¼"	725 x 650 x 1145	55.0	022-610
AFV 60X	60	VERT	8 BAR	½"F / ¾"M	1"	700 x 400 x ---	12.5	022-557
AFV 100X	100	VERT	8 BAR	½"F / ¾"M	1"	740 x 500 x ---	17.5	022-560
AFV 200X	200	VERT	8 BAR	½"F / ¾"M	1¼"	1035 x 600 x ---	48.3	022-590
AFV 300X	300	VERT	8 BAR	½"F / ¾"M	1¼"	1215 x 650 x ---	60.0	022-620
AFV 500X	500	VERT	8 BAR	½"F / ¾"M	1¼"	1360 x 775 x ---	80.0	022-622
AFV 24-16X	24	VERT	16 BAR	–	1"	480 x 270 x ---	6.0	022-631
AFV 100-16X	100	VERT	16 BAR	½"F / ¾"M	1"	740 x 500 x ---	25.0	022-632
AFV 200-16X	200	VERT	16 BAR	½"F / ¾"M	1¼"	1035 x 600 x ---	55.0	022-634
AFV 300-16X	300	VERT	16 BAR	½"F / ¾"M	1¼"	1215 x 650 x ---	70.0	022-635
AFV 500-16	500	VERT	16 BAR	½"F / ¾"M	2"	1865 x 650 x ---	90.0	022-636

PRESSURE BOOSTING SYSTEM ACCESSORIES

VAREM ACCUMULATOR PRESSURE VESSELS STAINLESS STEEL

E

Expansion vessels or also known as pressure vessels are to provide a reserve of pressurised water to limit the number of on/off cycling of water booster pumps. Within the vessel is a membrane which on one side is pressurised air and the other side is water (inside the membrane). When the pump system is started and a valve is closed water is pushed into the membrane, reaching the set pressure by the pressure switch. The system then holds at pressure. When water is drawn the pressurised air forces the water out until the pressure falls below the set level of the pressure switch and the pump will then re-start. All vessels are fitted with EPDM membranes.



MODEL	LITRES	STYLE	P MAX	AUX CON	MAIN CON	H x W x L mm	Kg	CODE
INOXVAREM 2	2	NO MOUNT	8 BAR	–	½"	225 x 135 x ---	1	022-700
INOXVAREM 8	8	NO MOUNT	8 BAR	–	¾"	340 x 200 x ---	2.2	022-701
INOXVAREM 20V	20	NO MOUNT	8 BAR	–	1"	492 x 270 x ---	4.5	022-702
INOXVAREM 20H	20	HORI	8 BAR	–	1"	286 x 492 x ---	4.5	022-705
INOXVAREM 50V	50	VERT	8 BAR	–	1"	863 x 365 x ---	12	022-703
INOXVAREM 50H	50	HORI	8 BAR	–	1"	450 x 655 x ---	12	022-706

REPLACEMENT MEMBRANES

MODEL	LITRES	CODE
5-8	5/8	022-710
20/24	20/24	022-711
50-60	50-60	022-712
100	100	022-713
200	200	022-714
300	300	022-715
500	500	022-716



PRESSURE BOOSTING SYSTEM ACCESSORIES

VAREM WRAS ACCUMULATOR PRESSURE VESSELS MILD STEEL

E

Expansion vessels, also known as pressure vessels, are to provide a reserve of pressurised water to limit the number of on/off cycling of water booster pumps. Within the vessel is a membrane which on one side is pressurised air and the other side is water (inside the membrane). When the pump system is started and a valve is closed water is pushed into the membrane, reaching the set pressure by the pressure switch. The system then holds at pressure. When water is drawn the pressurised air forces the water out until the pressure falls below the set level of the pressure switch and the pump will then re-start. **WRAS approved vessels are marked with a ***. All vessels are fitted with EPDM membranes. For replacement membranes see page 202.



MODEL	LITRES	STYLE	P MAX	AUX CON	MAIN CON	H x W x L mm	Kg	CODE
EXTRA VAREM 2*	2	NO MOUNT	8 BAR	–	½"	230 x 130 x ---	1.0	022-670
INTERVAREM 5*	5	NO MOUNT	8 BAR	–	¾"	332 x 160 x ---	1.8	022-671
INTERVAREM 8*	8	NO MOUNT	8 BAR	–	¾"	348 x 200 x ---	2.2	022-672
INTERVAREM 24*	24	NO MOUNT	8 BAR	–	1"	358 x 351 x ---	4.5	022-673
MAXIVAREM HOR 20*	20	HORI	8 BAR	–	1"	274 x 250 x 497	4.5	022-681
MAXIVAREM HOR 60*	60	HORI	8 BAR	–	1"	410 x 370 x 670	13	022-682
MAXIVAREM HOR 100*	100	HORI	8 BAR	½"	1"	485 x 450 x 756	17	022-683
MAXIVAREM HOR 200*	200	HORI	8 BAR	½"	1½"	602 x 550 x 825	37	022-684
MAXIVAREM HOR 300*	300	HORI	8 BAR	½"	1½"	654 x 640 x 1188	45	022-685
MAXIVAREM VT 60*	60	VERT	8 BAR	–	1"	825 x 379 x ---	13	022-675
MAXIVAREM VT 100*	100	VERT	8 BAR	½"	1"	910 x 450 x ---	17	022-676
MAXIVAREM VT 200*	200	VERT	8 BAR	½"	1½"	1250 x 554 x ---	37	022-677
MAXIVAREM VT 300*	300	VERT	8 BAR	½"	1½"	1370 x 624 x ---	46	022-678
MAXIVAREM VT 500*	500	VERT	8 BAR	½"	1½"	1460 x 775 x ---	100	022-679
PLUSVAREM LS P 8	8	VERT	16 BAR	–	1"	320 x 200 x ---	3	022-687
PLUSVAREM LS P 20	20	VERT	16 BAR	–	1"	509 x 250 x ---	8	022-688
PLUSVAREM LS PV 50	50	VERT	16 BAR	–	1"	759 x 379 x ---	12	022-689
PLUSVAREM LS PV 100	100	VERT	16 BAR	½"	1"	910 x 450 x ---	28	022-691
PLUSVAREM LS PV 200	200	VERT	16 BAR	½"	1½"	1250 x 554 x ---	52	022-692
PLUSVAREM LS PV 300	300	VERT	14 BAR	½"	1½"	1370 x 624 x ---	61	022-693
PLUSVAREM LS PV 500	495	VERT	12 BAR	½"	1½"	1460 x 775 x ---	125	022-696

SURFACE MOUNTED PUMPS

SPECIAL BUILDS

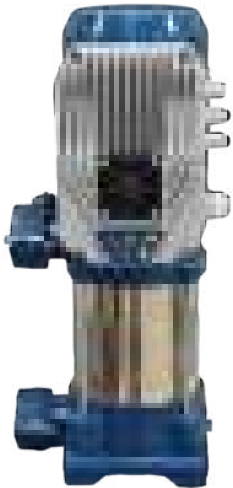

PRESSURE BOOSTING SYSTEM ACCESSORIES

NC ACCUMULATOR PRESSURE VESSELS

E

Budget lower cost expansion vessels or also known as pressure vessels are to provide a reserve of pressurised water to limit the number of on/off cycling of water booster pumps. Within the vessel is a membrane which on one side is pressurised air and the other side is water (inside the membrane). When the pump system is started and a valve is closed water is pushed into the membrane, reaching the set pressure by the pressure switch. The system then holds at pressure. When water is drawn the pressurised air forces the water out until the pressure falls below the set level of the pressure switch and the pump will then re-start. All vessels are fitted with EPDM membranes.



MODEL	LITRES	STYLE	P MAX	AUX CON	MAIN CON	H x W x L mm	Kg	CODE
NC8 MILD STEEL	8	VERT	10	–	1"	340 x 210 x ---	2.3	022-650
NC24H MILD STEEL	24	HORI	10	–	1"	300 x 280 x 470	5.0	022-652
NC24V MILD STEEL	24	VERT	10	–	1"	460 x 270 x ---	5.0	022-654
NCS8 S/STEEL	8	VERT	10	–	1"	300 x 180 x ---	1.8	022-658
NCS24H S/STEEL	24	HORI	10	–	1"	310 x 270 x 450	4.8	022-660
NCS24V S/STEEL	24	VERT	10	–	1"	460 x 270 x ---	5.0	022-662
NCS60V S/STEEL	60	VERT	10	–	1"	640 x 450 x 450	9.0	022-664
NCS60H S/STEEL	60	HORI	10	–	1"	480 x 450 x 480	9.0	022-665

REPLACEMENT MEMBRANES

MODEL	LITRES	CODE
NC8	8	N/A
NC24	24	022-535
NC60	60	022-537

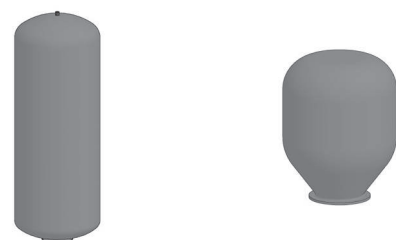

ACCESSORIES

PLASTIC FITTINGS

A



SIZE	MALE HOSE TAIL CODE	FEMALE HOSE TAIL CODE	MALE ELBOW HOSE TAIL CODE	FEMALE ELBOW HOSE TAIL CODE	SIZE
1/2"	030-202	-	-	-	1/2"
3/4"	030-203	030-205	060-064	060-072	3/4"
1"	030-207	030-209	060-066	060-074	1"
1 1/4"	030-212	030-214	060-068	060-076	1 1/4"
1 1/2"	030-215	030-217	060-070	060-078	1 1/2"
2"	030-226	030-228	-	060-080	2"
2 1/2"	-	-	-	-	2 1/2"
3"	030-231	030-233	-	-	3"
4"	030-236	030-238	-	-	4"



SIZE	MALE/MALE NIPPLE CODE	FEMALE/FEMALE SOCKET CODE	SIZE	REDUCING BUSHES SIZE	CODE
1/2"	061-502	061-641	1/2"	1 1/4" - 1"	061-626
3/4"	061-504	061-642	3/4"	1 1/2" - 1 1/4"	061-628
1"	061-506	061-643	1"	2" - 1 1/4"	061-632
1 1/4"	061-508	061-644	1 1/4"	2" - 1"	061-633
1 1/2"	061-510	061-645	1 1/2"	2" - 1 1/2"	061-634
2"	061-514	061-646	2"	2 1/2" - 2"	061-636
2 1/2"	061-516	061-647	2 1/2"	3" - 2"	061-638
3"	061-518	061-648	3"	3" - 2 1/2"	061-639
4"	061-519	061-649	4"	4" - 3"	061-619



MODEL	SIZE	CODE
FEMALE STEP ADAPTER	1 1/4" FEMALE x 1" - 3/4" - 1/2"	030-241
MALE STEP ADAPTER	1 1/4" MALE x 1" - 3/4" - 1/2"	030-239

ACCESSORIES

BRASS FITTINGS

A

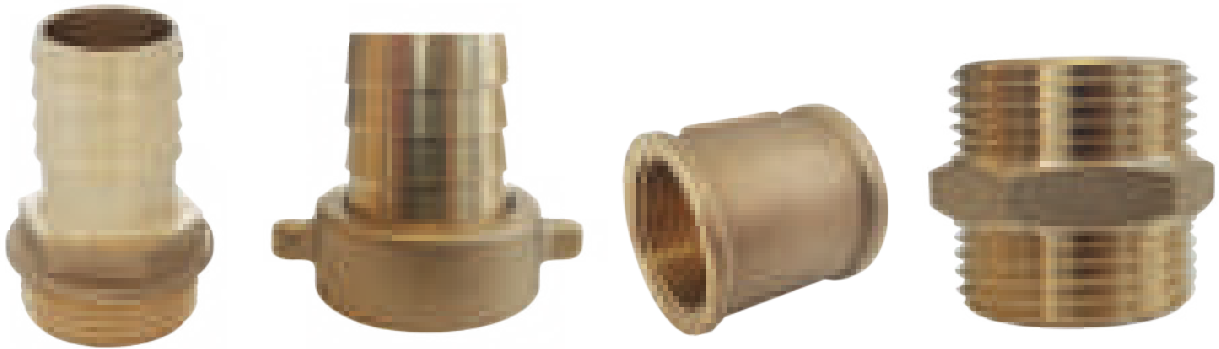

SIZE	MALE BRASS HOSE TAIL CODE	FEMALE BRASS HOSE TAIL CODE	BRASS BARREL SOCKET CODE	BRASS NIPPLE CODE	SIZE
1/2"	060-006	060-017	060-480	060-502	1/2"
3/4"	060-008	060-018	060-482	060-504	3/4"
1"	060-014	060-020	060-484	060-506	1"
1 1/4"	060-016	030-219	060-486	060-508	1 1/4"
1 1/2"	030-223	030-221	060-488	060-510	1 1/2"
2"	030-225	030-227	060-490	060-514	2"
2 1/2"	030-229	-	060-492*	060-516	2 1/2"
3"	030-234	-	060-493*	060-518	3"
4"	030-235	-	060-489*	060-519	4"

*GALVANISED

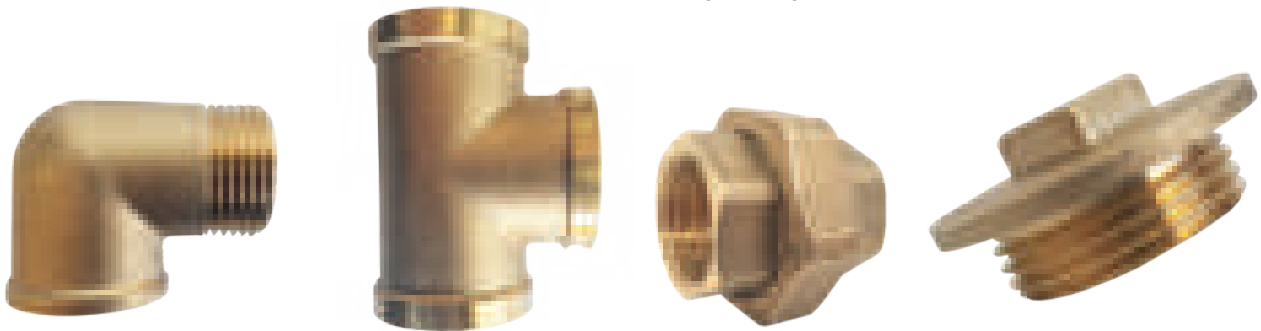

SIZE	BRASS M/F ELBOW CODE	BRASS F/F/F TEE CODE	BRASS 3 PART UNION CODE	BRASS MALE PLUG CODE	SIZE
1/2"	060-600	060-640	060-494	060-522	1/2"
3/4"	060-602	060-642	060-495	060-524	3/4"
1"	060-604	060-644	060-496	060-526	1"
1 1/4"	060-606	060-646	060-497	060-528	1 1/4"
1 1/2"	060-608	060-648	060-498	060-530	1 1/2"
2"	060-610	060-650	060-499	060-534	2"
2 1/2"	060-612*	060-652	-	-	2 1/2"
3"	060-614*	060-654*	-	-	3"
4"	060-615*	060-656*	-	-	4"

*GALVANISED

*GALVANISED

ACCESSORIES

BRASS FITTINGS

A

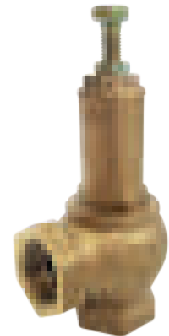
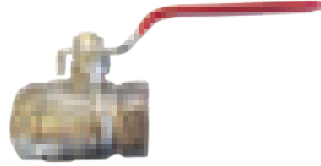

SIZE	BRASS GATE VALVES CODE	BRASS BALL VALVES CODE	INLINE BRASS FILTER CODE	PRESSURE RELIEF VALVES CODE	SIZE
1/2"	060-190	060-150	060-092	060-470	1/2"
3/4"	060-192	060-152	060-094	060-472	3/4"
1"	060-194	060-154	060-096	060-474	1"
1 1/4"	060-196	060-156	060-098	060-475	1 1/4"
1 1/2"	060-198	060-158	060-100	060-476	1 1/2"
2"	060-200	060-160	060-102	060-477	2"
2 1/2"	060-202	060-161	060-104	-	2 1/2"
3"	060-204	060-162	060-106	060-479	3"
4"	060-206	060-164	060-108	-	4"



SIZE	BRASS NON RETURN VALVE CODE	BRASS SWING CHECK VALVE CODE	S/S SCREW IN FILTER CODE	FOOTVALVE CODE	SIZE
1/2"	060-128	-	060-460	-	1/2"
3/4"	060-130	-	060-462	060-110	3/4"
1"	060-132	030-025	060-464	060-112	1"
1 1/4"	060-134	030-032	060-465	060-114	1 1/4"
1 1/2"	060-136	030-040	060-466	060-116	1 1/2"
2"	060-137	030-050	060-467	060-118	2"
2 1/2"	060-138	030-065	060-468	060-119	2 1/2"
3"	060-139	030-080	060-469	060-120	3"
4"	060-140	030-100	060-651	060-122	4"

ACCESSORIES

BRASS REDUCING BUSHES

A



SIZE	CODE	SIZE	CODE
3/4" - 1/2"	060-620	2" - 1"	060-633
1" - 3/4"	060-622	2" - 1 1/4"	060-632
1" - 1/2"	060-624	2" - 1 1/2"	060-634
1 1/4" - 1"	060-626	2 1/2" - 2"	060-636
1 1/2" - 1"	060-630	3" - 2"	060-638*
1 1/2" - 1 1/4"	060-628	3" - 2 1/2"	060-639*

*GALVANISED

BRASS QUICK COUPLING FITTINGS

A



SIZE	QUICK COUPLER FEMALE CODE	QUICK COUPLER MALE CODE	QUICK COUPLER HOSE TAIL CODE	SIZE
1/2"	060-540	060-554	060-586	1/2"
3/4"	060-542	060-556	060-588	3/4"
1"	060-544	060-558	060-590	1"
1 1/4"	060-546	060-560	060-592	1 1/4"
1 1/2"	060-548	060-562	060-594	1 1/2"



ITEM	CODE
QUICK COUPLING 3 WAY ADAPTER	060-576
QUICK COUPLING BLANKING CAP	060-566
QUICK COUPLING REPLACEMENT GASKET	060-538



Matic float switches see pages 85 - 87

ACCESSORIES

THREADED & FLANGED BALL RETAINING VALVES

A

Ball retaining valves for waste water, suitable for heavy duty applications. The special chemical structure of NBR rubber, coating the stainless steel ball, allows the application with liquids of different viscosity and/or chemically aggressive and liquids having temperatures from 0° to 100°C. The use of rubber coating on all available diameters, improves quality and life of valves reducing water hammer problems assuring noiseless installations. Suitable for sewage and waste. 10 bar maximum pressure.



DESCRIPTION	PCD	HOLES	Kg	CODE
1" THREADED	-	-	4	060-738
1¼" THREADED	-	-	4	060-740
1½" THREADED	-	-	4	060-741
2" THREADED	-	-	6	060-742
2½" THREADED	-	-	10	060-743
DN50 FLANGED PN16	125	18mm x 4	9.5	060-744
DN65 FLANGED PN16	145	18mm x 4	13	060-745
DN80 FLANGED PN16	160	18mm x 8	16.5	060-746
DN100 FLANGED PN16	180	18mm x 8	23	060-747
DN150 FLANGED PN16	240	22mm x 8	49	060-748
DN200 FLANGED PN10	295	22mm x 8	97	060-749

ACCESSORIES

ALUMINIUM CAM LEVER LOCK COUPLINGS

A

Aluminium camlocks also known as cam and groove couplings are quick and easy connect and disconnect couplings for hose pipes and pipework. Camlock couplings operate by opening the coupler arms and inserting the adaptor into the coupling. The arms are then pressed and folded down into position to make a tight joint. Camlocks are normally classified as Type A, Type B, Type C, Type D, Type E, Type F, Type DP and Type DC.

CAM COUPLING PART A	CODE
1"	CAM A 1 AL
1¼"	CAM A 1 1/4 AL
1½"	CAM A 1 1/2 AL
2"	CAM A 2 AL
3"	CAM A 3 AL
4"	CAM A 4 AL
6"	CAM A 6 AL



CAM COUPLING PART B	CODE
1"	CAM B 1 AL
1¼"	CAM B 1 1/4 AL
1½"	CAM B 1 1/2 AL
2"	CAM B 2 AL
3"	CAM B 3 AL
4"	CAM B 4 AL
6"	CAM B 6 AL



CAM COUPLING PART C	CODE
1"	CAM C 1 AL
1¼"	CAM C 1 1/4 AL
1½"	CAM C 1 1/2 AL
2"	CAM C 2 AL
3"	CAM C 3 AL
4"	CAM C 4 AL
6"	CAM C 6 AL



CAM COUPLING PART D	CODE
1"	CAM D 1 AL
1¼"	CAM D 1 1/4 AL
1½"	CAM D 1 1/2 AL
2"	CAM D 2 AL
3"	CAM D 3 AL
4"	CAM D 4 AL
6"	CAM D 6 AL



ACCESSORIES

ALUMINIUM CAM LEVER LOCK COUPLINGS

A

Aluminium camlocks also known as cam and groove couplings are quick and easy connect and disconnect couplings for hose pipes and pipework. Camlock couplings operate by opening the coupler arms and inserting the adaptor into the coupling. The arms are then pressed and folded down into position to make a tight joint. Camlocks are normally classified as Type A, Type B, Type C, Type D, Type E, Type F, Type DP and Type DC.

CAM COUPLING PART E	CODE
1"	CAM E 1 AL
1¼"	CAM E 1 1/4 AL
1½"	CAM E 1 1/2 AL
2"	CAM E 2 AL
3"	CAM E 3 AL
4"	CAM E 4 AL
6"	CAM E 6 AL



CAM COUPLING PART F	CODE
1"	CAM F 1 AL
1¼"	CAM F 1 1/4 AL
1½"	CAM F 1 1/2 AL
2"	CAM F 2 AL
3"	CAM F 3 AL
4"	CAM F 4 AL
6"	CAM F 6 AL



CAM COUPLING PART DC	CODE
1"	CAM DC 1 AL
1¼"	CAM DC 1 1/4 AL
1½"	CAM DC 1 1/2 AL
2"	CAM DC 2 AL
3"	CAM DC 3 AL
4"	CAM DC 4 AL
6"	CAM DC 6 AL



CAM COUPLING PART DP	CODE
1"	CAM DP 1 AL
1¼"	CAM DP 1 1/4 AL
1½"	CAM DP 1 1/2 AL
2"	CAM DP 2 AL
3"	CAM DP 3 AL
4"	CAM DP 4 AL
6"	CAM DP 6 AL



ACCESSORIES

POLYPROPYLENE CAM LEVER LOCK COUPLINGS

A

Polypropylene camlocks also known as cam and groove couplings are quick and easy connect and disconnect couplings for hose pipes and pipework. Camlock couplings operate by opening the coupler arms and inserting the adaptor into the coupling. The arms are then pressed and folded down into position to make a tight joint. Camlocks are normally classified as Type A, Type B, Type C, Type D, Type E, Type F, Type DP and Type DC.

CAM COUPLING PART A	CODE
1"	CAM A 1 PP
1¼"	CAM A 1 1/4 PP
1½"	CAM A 1 1/2 PP
2"	CAM A 2 PP
3"	CAM A 3 PP
4"	CAM A 4 PP



CAM COUPLING PART B	CODE
1"	CAM B 1 PP
1¼"	CAM B 1 1/4 PP
1½"	CAM B 1 1/2 PP
2"	CAM B 2 PP
3"	CAM B 3 PP
4"	CAM B 4 PP



CAM COUPLING PART C	CODE
1"	CAM C 1 PP
1¼"	CAM C 1 1/4 PP
1½"	CAM C 1 1/2 PP
2"	CAM C 2 PP
3"	CAM C 3 PP
4"	CAM C 4 PP



CAM COUPLING PART D	CODE
1"	CAM D 1 PP
1¼"	CAM D 1 1/4 PP
1½"	CAM D 1 1/2 PP
2"	CAM D 2 PP
3"	CAM D 3 PP
4"	CAM D 4 PP



ACCESSORIES

POLYPROPYLENE CAM LEVER LOCK COUPLINGS

A

Polypropylene camlocks also known as cam and groove couplings are quick and easy connect and disconnect couplings for hose pipes and pipework. Camlock couplings operate by opening the coupler arms and inserting the adaptor into the coupling. The arms are then pressed and folded down into position to make a tight joint. Camlocks are normally classified as Type A, Type B, Type C, Type D, Type E, Type F, Type DP and Type DC.

CAM COUPLING PART E	CODE
1"	CAM E 1 PP
1¼"	CAM E 1 1/4 PP
1½"	CAM E 1 1/2 PP
2"	CAM E 2 PP
3"	CAM E 3 PP
4"	CAM E 4 PP



CAM COUPLING PART F	CODE
1"	CAM F 1 PP
1¼"	CAM F 1 1/4 PP
1½"	CAM F 1 1/2 PP
2"	CAM F 2 PP
3"	CAM F 3 PP
4"	CAM F 4 PP



CAM COUPLING PART DC	CODE
1"	CAM DC 1 PP
1¼"	CAM DC 1 1/4 PP
1½"	CAM DC 1 1/2 PP
2"	CAM DC 2 PP
3"	CAM DC 3 PP
4"	CAM DC 4 PP



CAM COUPLING PART DP	CODE
1"	CAM DP 1 PP
1¼"	CAM DP 1 1/4 PP
1½"	CAM DP 1 1/2 PP
2"	CAM DP 2 PP
3"	CAM DP 3 PP
4"	CAM DP 4 PP



ACCESSORIES

TIN CAN STRAINERS / HOSE JOINERS / HOSE CLIPS / ENGINE OIL

A



STAINLESS STEEL HOSE CLIPS



STAINLESS STEEL BOLT CLAMPS



TIN CAN STRAINER



HOSE JOINER

SIZE	STANDARD TIN CAN STAINER CODE	ALUMINIUM HOSE JOINERS CODE	STAINLESS STEEL HOSE CLIPS CODE	SIZE
1/2"	-	-	030-268	1/2"
3/4"	-	-	030-269	3/4"
1"	060-830	060-757*	030-270	1"
1 1/4"	060-832	060-758	030-272	1 1/4"
1 1/2"	060-834	060-759	030-274	1 1/2"
2"	060-836	060-750	030-276	2"
2 1/2"	-	-	030-277	2 1/2"
3"	060-838	060-752	030-278	3"
4"	060-840	060-754	030-280	4"
6"	060-841	060-756	030-282	6"

* BRASS

SIZE	STAINLESS STEEL BOLT CLAMPS LAYFLAT CODE	DESCRIPTION	GRADE	SIZE	Kg	CODE
2" 52-55mm	030-250	ENGINE OIL	5W-30	1 LITRE	0.92	710-710
3" 80-85mm	030-252					
4" 104-112mm	030-254					
6" 149-161mm	030-256					
S/STEEL BOLT CLAMPS SUCTION HOSE						
2" 56-59mm	030-260					
3" 80-85mm	030-252					
4" 104-112mm	030-254					
6" 162-174mm	030-266					



Semi-synthetic, fuel efficient multigrade engine oil meeting the latest API classifications. This 5W-30 is manufactured from a balanced blend of top quality mineral and synthetic base stocks, producing a high quality.

ACCESSORIES

POWER CABLES & FLOAT SWITCHES

E

Mac3 float switch fitted with 'cabtyre' fixing gland suits JS single phase pumps as well as some other manufacturers' pumps. Power cables for single phase pumps and three phase pumps again fitted with the 'cabtyre' fixing gland suits JS pumps as well as some other manufacturers' pumps. 3 phase power cables suit up to 1.5Kw in the JS range. The Agma float is used in many installations where a standard float switch cannot operate. Complete with 10 metres of power cable. Pentair Nocchi replacement float switches and power cables for the Drenox, Omnia, Biox and PrioX range. New to the range is the mouse. Similar to the AGMA, this has two floating bodies that can be moved along the shaft to regulate the minimum and maximum level. Can be used in auto and manual mode. Complete with 10 metres of power cable.



MAC3



POWER CABLE



PENTAIR/NOCCHI
FLOAT SWITCH



MOUSE WITH CABTYRE
GLAND FIXING



AGMA C/W 10m CABLE



PENTAIR/NOCCHI 10m POWER CABLE

DESCRIPTION	Kg	CODE
PUMP POWER CABLE 10 METRE 1.5mm 3 CORE 110v/230v	1.5	030-705
PUMP POWER CABLE 10 METRE 1.5mm 4 CORE 400v	1.6	030-720
MAC3 FLOAT	1	020-001
AGMA 22 MAGNETIC	1.5	020-003
PENTAIR/NOCCHI PUMP POWER CABLE 10 METRE 110v/230v	1.5	ZBR20460
PENTAIR/NOCCHI PUMP FLOAT SWITCH	0.5	ZBR20450
MOUSE	1.2	020-002

WELL AND BOREHOLE PUMPS

BASIC GUIDE FOR SELECTING A WELL AND BOREHOLE PUMP

Vertical depth of borehole	metres	On site calculation
Extra vertical head from top of borehole	metres	On site calculation
Horizontal run from top of borehole	metres	On site calculation
Amount of water required in litres per min	L/M Litres Per Min	
Pressure required at end of pipe	Bar	
Internal bore of pipe	inches / mm	If possible keep to cartridge outlet size to ensure maximum performance
Pump complete or borehole Cartridge Selection	4S /	See pages 232 – 235 Also see pipe resistance chart

GUIDE FOR SELECTING A BOREHOLE MOTOR

Voltage required	230v or 400v	On site calculation
Kw Required for cartridge = Kw Motor	kW	See page 231
Length of Cable Required	Metres	
Cable size recommendation	mm	See page 237

CONTROL PANELS AND ACCESSORIES

Type of Control Panel required	Switch/Overload Box	See page 230
	Basic Control panel	See page 78 & 79
	Pilot Control	See page 219
	Submatic Q	See page 83
Cable Joining Kits	1.0mm 4 Core to 4mm 4 Core	See page 237
	6mm 4 Core to 10mm 4 Core	See page 237
Extension cable		See page 237

The more information given to us the more we can assist with your application. Complete this form and return to us.

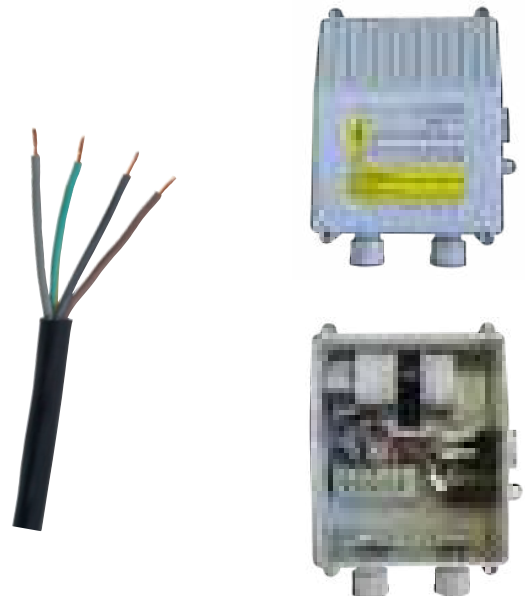
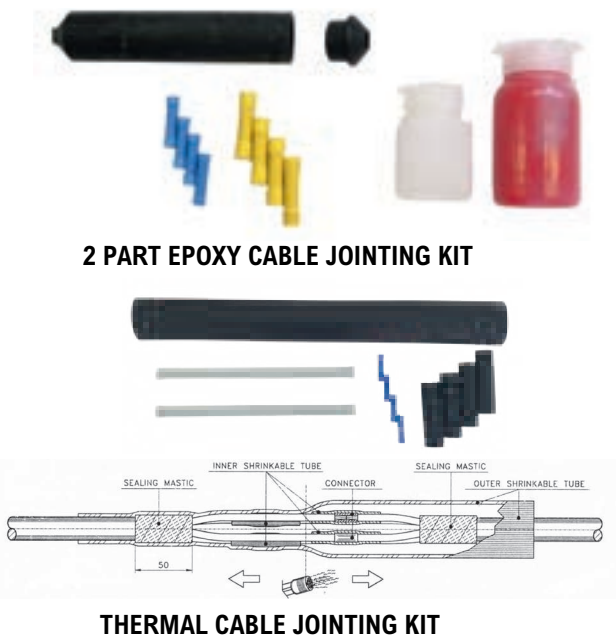

CAPACITOR/OVERLOAD BOX

WELL AND BOREHOLE PUMPS

NASTEC PILOT

E

PILOT is an electronic device for the control of single phase and three phase motors (pumps) which provides protection against: dry running, overcurrent, phase loss, excessive number of starts.

The backlit LCD displays the running current and PILOT stops the pump if the maximum value set by the user is exceeded. The maximum number of pump starts is also user selectable and PILOT will stop the pump operation if this value is exceeded.

Dry running

PILOT provides a display of the power factor value (P.F. or $\cos\phi$) and allows the user to set a minimum threshold value for normal operation. PILOT will stop the pump below this value to protect against dry running. PILOT will make up to 5 automatic restart attempts following an alarm condition at time intervals set by the user.

Replaces existing control box and can be wired to a pressure switch or a float.



120 mm

180 mm

180 mm

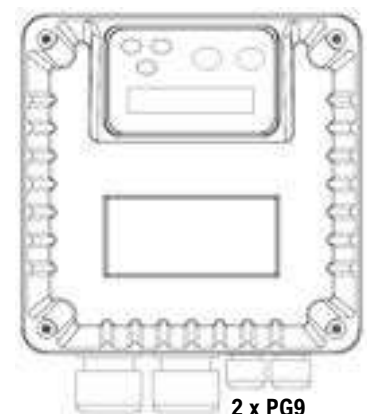

2 x PG21

2 x PG9

MODEL	Kg	VOLTAGE +/- 10%	MAX AMPS	CODE
PILOT 112	2	1 x 230v	12A	PILOT 112
PILOT 118	2	1 x 230v	18A	PILOT 118
PILOT 312	2.2	3 x 400v	12A	PILOT 312
PILOT 325	2.4	3 x 400v	25A	PILOT 325

WELL AND BOREHOLE PUMPS

WELL BUDDY 1000A & 1000P

A

Well Buddy 1000A and P are a plastic multistage pump with stainless steel casing. For clean water applications only with no suspended solids or abrasive material. These pumps have 4 stage impellers and can reach a maximum of 40 metres (4 Bar). Model A comes supplied with a 10 metre power cable, float switch and 1”-3/4” reducing hose connector. Model P has a built in pressure switch designed to automatically start and stop the pump, also with dry run protection. 15 metres power cable and built in non return valve, 1” & 3/4” hose connections.

Features

High Pressure
High Flow

Applications

Rain Water Systems
Sprinklers
Tanks

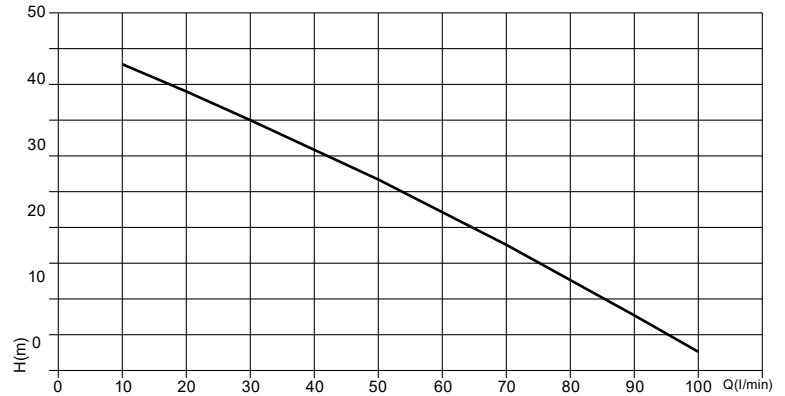

1000A



1000P



MODEL	VOLTAGE	OUTLET	LM/HM	Kw	AMP	H x W x L mm	Kg	CODE
WELL BUDDY 1000A	230v	1” BSP	110/45	1	4.5	438 x 151 x 151	11	022-950
WELL BUDDY 1000P	230v	1” BSP	100/45	1	4.9	535 x 150 x 150	13	022-952

WELL AND BOREHOLE PUMPS

ECO DIVER 1200 & DIVERTRON 1200

C

Eco Diver is suitable to pump clean water with no suspended solids or abrasive materials. Manufactured with anti-corrosive and rust proof materials. Supplied with 15 metre power cable, non return valve and step adapter hose fitting. Divertron 1200 is the same as the Eco Diver but has built in electronics, pressure switch and flow sensor designed to automatically start and stop the pump. Also with dry run protection.

Features

- High Pressure
- High Flow

Applications

- Rain Water Systems
- Sprinklers
- Tanks

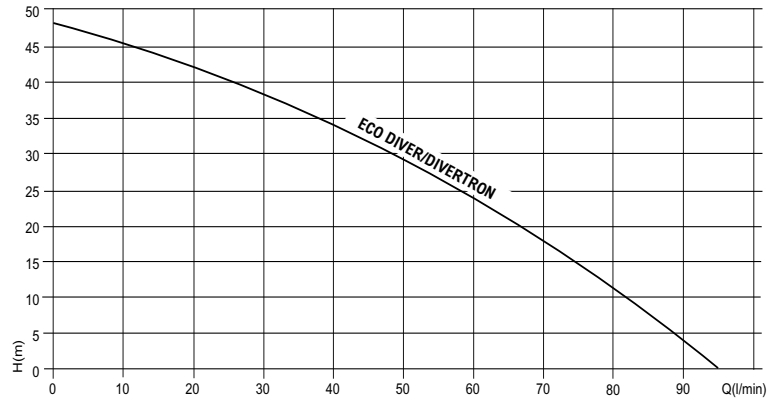

ECO DIVER



DIVERTRON 1200



EXAMPLES OF USE



MODEL	VOLT	OUTLET	LM/HM	Kw	AMP	H x W x L mm	Kg	CODE
ECO DIVER AUTO	230v	1"	95/48	1.1	4.8	400 x 150 x 150	9.0	022-832
DIVERTRON	230v	1"	95/48	1.1	4.8	480 x 150 x 150	11.0	022-835

WELL AND BOREHOLE PUMPS

JS-530 WELL BUDDY

A

The Well Buddy is ready to be used in traditional wells, installation in home for pressurization, small scale irrigation systems, water deposits, water harvesting and collection tanks. Suitable for clean water only with no solids or abrasives. No hoesail is supplied. Must not be allowed to run dry under any circumstances.

Features

High Pressure
High Flow

Applications

Rain Water Systems
Sprinklers
Tanks

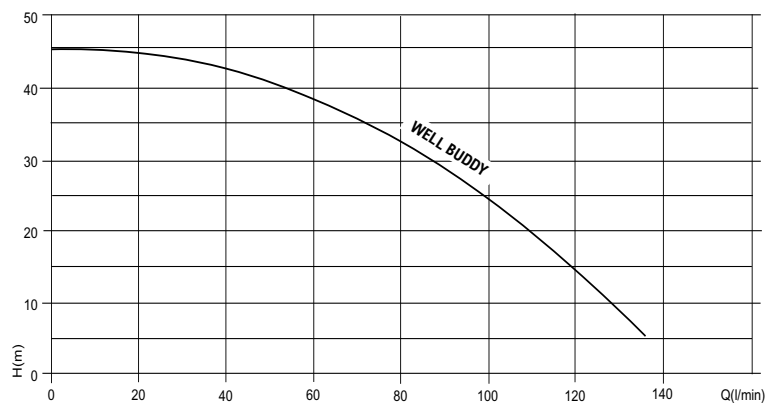

EXAMPLES OF USE



MODEL	VOLT	OUTLET	LM/HM	Kw	AMP	H x W x L mm	Kg	CODE
JS-530 WELL BUDDY MAN	230v	1"	140/45	1.3	5.8	520 x 200 x 235	17.0	011-530
JS-530 WELL BUDDY AUTO	230v	1"	140/45	1.3	5.8	520 x 200 x 235	17.0	011-530A
JS-530 WELL BUDDY AUTO	110v	1"	140/45	1.3	11.6	520 x 200 x 235	17.0	011-532A

WELL AND BOREHOLE PUMPS

PENTAX 3S 3" BOREHOLE PUMP

E

Subline / Pentax 3S submersible multistage pumps, particularly designed for clean water boosting, rain water collection tanks, pressure boosting sets and irrigation. 1" female Outlet. 1.5m cable fly lead supplied from motor. For additional cable and joining kits see page 237. Stainless steel construction with noryl impellers and diffusers. Non return valve built into discharge head. For capacitor/overload boxes see page 230.





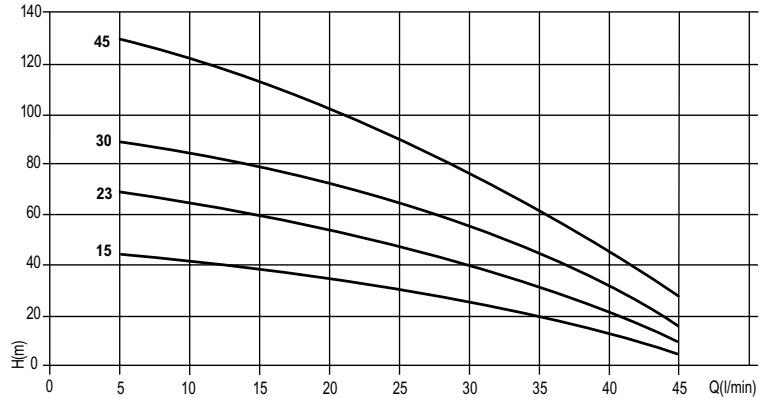

Features

3" Borehole
High Pressure

Applications

Irrigation
Pressure Boosting



- 1  BRASS DISCHARGE HEAD.
- 2  DISCHARGE HEAD NON RETURN VALVE.
- 3  UPPER BUSH MADE IN ANTI SAND RUBBER.
- 4  IMPELLERS IN NORYL AND DIFFUSERS IN SELF-LUBRICATING POLYACETAL.
- 5  STAINLESS STEEL SHELL.
- 6  STAINLESS STEEL STRAINER.
- 7  BRASS BRACKET TO COUPLE TO THE MOTOR.



MODEL	VOLT	OUTLET	LM/HM	Kw	AMP	H x W x L mm	Kg	CODE
3S 3-15	230v	1"	45/46	0.33	3.75	957 x 74 x ---	9.3	022-920
3S 3-23	230v	1"	45/70	0.55	4.5	1157 x 74 x ---	10.5	022-922
3S 3-30	230v	1"	45/92	0.75	5.85	1395 x 74 x ---	12.0	022-924
3S 3-45	400v	1"	45/128	1.1	3.2	1796 x 74 x ---	14.4	022-926

WELL AND BOREHOLE PUMPS

VENUS & IDEA 100 4" BOREHOLE PUMP

E

Single impeller peripheral borehole pump for 4 inch wells or larger. Suitable for water lifting and distribution applications in small agricultural concerns, domestic systems and pressurisation of pressure vessels. Venus pump body and impeller are brass. Idea 100 pump body is cast iron. Graphite/alumina mechanical seal and lip seal. Pump comes complete with start capacitor and overload protection in a plastic enclosure. Temperature range from 0° to +40° C Max. Maximum submersion depth 20m. Suitable for clean water free from solids or abrasive contaminants. Removable 15m of power cable.

Features

4" Borehole
High Pressure
Compact Design

Applications

Irrigation
Pressure Boosting

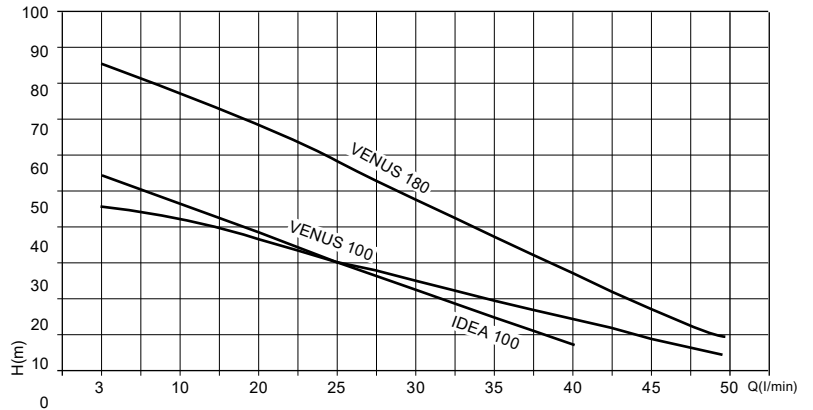

VENUS



IDEA 100

MODEL	VOLT	OUTLET	LM/HM	Kw	AMP	H x W x L mm	Kg	CODE
VENUS 100	230v	1"	50/47	0.75	2	460 x 98 x ---	15	022-790
VENUS 180	230v	1"	50/87	1.33	10	500 x 98 x ---	18	022-792
IDEA 100	110v	1"	40/55	0.75	4.7	512 x 93 x ---	12	022-818

WELL AND BOREHOLE PUMPS

PENTAX 5PES 5" BOREHOLE PUMP

E

Pentax 5PES submersible multistage pumps, particularly designed for clean water boosting, rain water collection tanks, pressure boosting sets and irrigation. Complete with 20 metres of power cable. 1¼" female outlet. Stainless steel pump case, impellers and diffusers. Internal capacitor.

Features

5" Borehole
High Pressure
Compact Design

Applications

Irrigation
Pressure Boosting

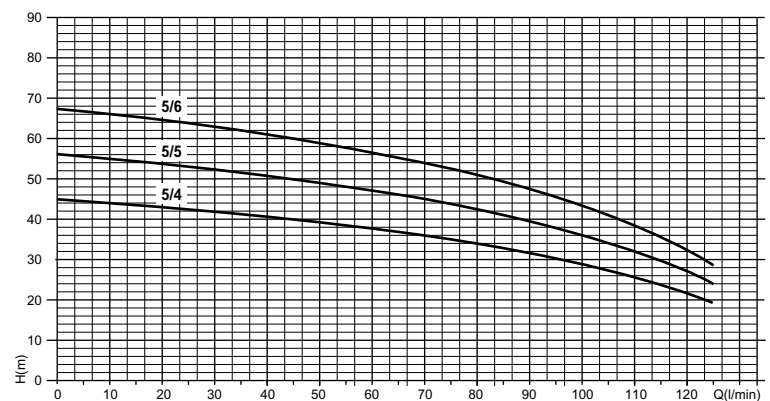
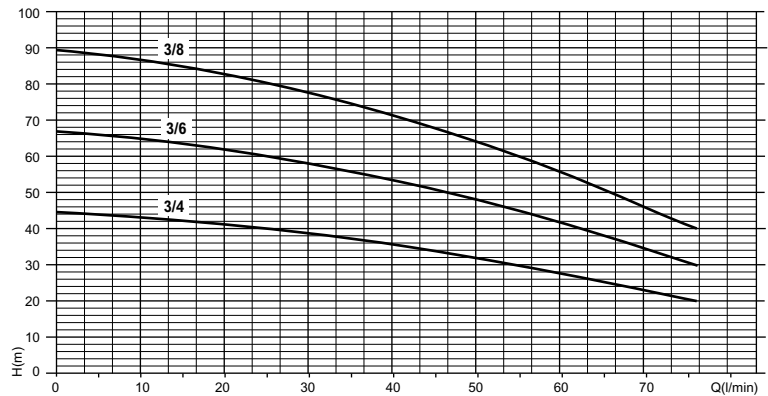

MODEL	VOLT	OUTLET	LM/HM	Kw	AMP	H x W x L mm	Kg	CODE
5PES 3/4 MANUAL	230v	1¼"	70/45	0.55	4.5	470 x 134 x ---	13.8	022-750
5PESG 3/4 AUTO	230v	1¼"	70/45	0.55	4.5	470 x 134 x ---	13.8	022-752
5PES 3/6 MANUAL	230v	1¼"	70/67	0.75	5.6	568 x 134 x ---	16.2	022-754
5PESG 3/6 AUTO	230v	1¼"	70/67	0.75	5.6	568 x 134 x ---	16.2	022-756
5PES 3/8 MANUAL	230v	1¼"	70/90	1.1	7.2	616 x 134 x ---	19.4	022-758
5PESG 3/8 AUTO	230v	1¼"	70/90	1.1	7.2	616 x 134 x ---	19.4	022-760
5PES 3/8 MANUAL	400v	1¼"	70/90	1.1	2.7	616 x 134 x ---	19.4	022-762
5PES 5/4 MANUAL	230v	1¼"	125/45	0.75	5.4	470 x 134 x ---	14.8	022-764
5PES 5/4 AUTO	230v	1¼"	125/45	0.75	5.4	470 x 134 x ---	14.8	022-765
5PES 5/5 MANUAL	230v	1¼"	125/56	0.9	6.5	544 x 134 x ---	17.6	022-767
5PES 5/5 AUTO	230v	1¼"	125/56	0.9	6.5	544 x 134 x ---	17.6	022-768
5PES 5/6 MANUAL	230v	1¼"	125/68	1.1	7.6	568 x 134 x ---	18.2	022-770
5PES 5/6 AUTO	230v	1¼"	125/68	1.1	7.6	568 x 134 x ---	18.2	022-771
5PES 5/6 MANUAL	400v	1¼"	125/68	1.1	2.8	568 x 134 x ---	17.4	022-774

WELL AND BOREHOLE PUMPS

PENTAIR NOCCHI DOMINATOR 4" & 5" BOREHOLE PUMP

E

Dominator 4" & 5" models complete with 20m 3 core cable, Internal capacitor, stainless steel pump casing and suction screen, mechanical seal and integrated non-return valve. Clean water only with a maximum water temp of 40°C. Maximum submersion depth 20m. Dominator 4" has acetal resin impellers, polycarbonate diffusers. Dominator 5" has stainless steel impellers and diffusers. Ideal for 4" and 5" wells for water distribution.

Features

4" Borehole
5" Borehole
High Pressure
Compact Design

Applications

Irrigation
Pressure Boosting

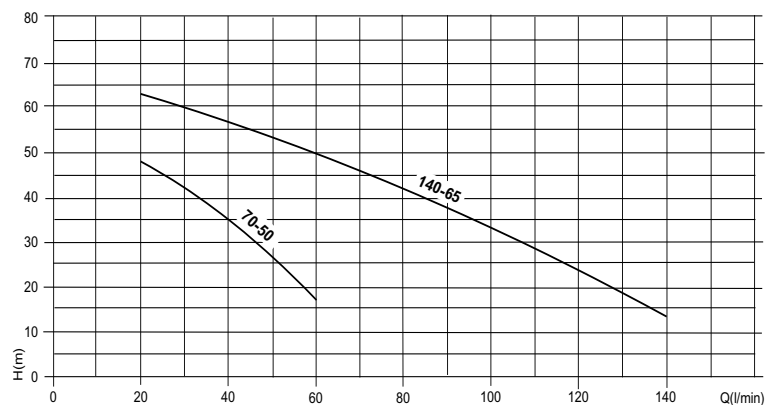
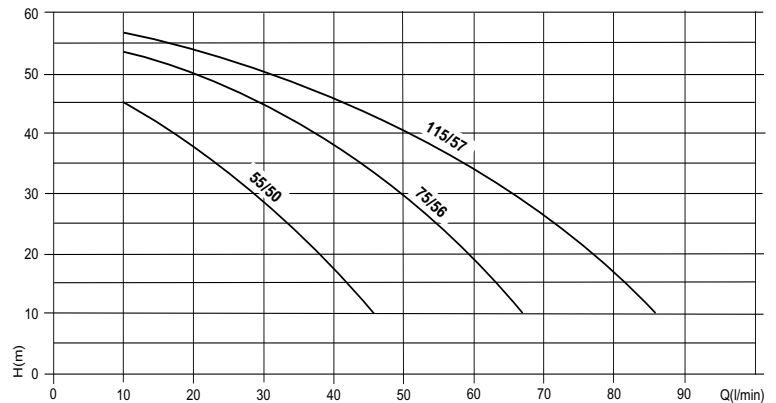

MODEL	VOLT	OUTLET	LM/HM	Kw	AMP	H x W x L mm	Kg	CODE
DOMINATOR 4" 55/50M	230v	1¼"	50/45	0.56	3.8	549 x 98 x ---	10.4	320-0040
DOMINATOR 4" 75/56M	230v	1¼"	70/54	0.60	3.3	643 x 98 x ---	10.8	320-0050
DOMINATOR 4" 115/57M	230v	1¼"	90/56	0.8	5.0	643 x 98 x ---	10.8	320-0030
DOMINATOR 5" 70/50 MAN	230v	1¼"	60/47	0.6	4	475 x 132 x ---	13.7	319-1000
DOMINATOR 5" 70/50M AUTO	230v	1¼"	60/47	0.6	4	475 x 132 x ---	13.7	319-1010
DOMINATOR 5" 140/65 MAN	230v	1¼"	140/63	1.1	7.2	550 x 132 x ---	15.8	319-1060
DOMINATOR 5" 140/65 AUTO	230v	1¼"	140/63	1.1	7.2	550 x 132 x ---	15.8	319-1070

WELL AND BOREHOLE PUMPS

DIVER HF

D

DIVER pumps are used for pumping clean water from boreholes, water tanks and wells and are capable of distributing pressurised water to domestic installations, small agricultural plants, and sprinkler systems for lawns and vegetable gardens. 1¼" female outlet. Noryl impellers and diffusers. Silicon carbide mechanical seal. Single phase versions come complete with overload/capacitor box. 10 metre power cable.

Features

High Flow
Compact Design

Applications

Irrigation
Pressure Boosting

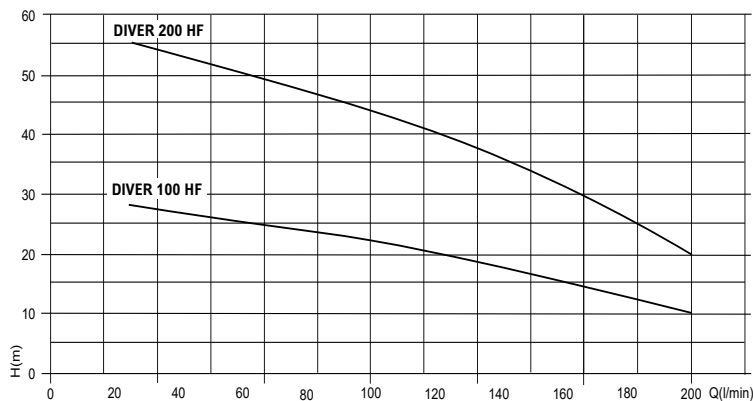

DIVER HF

MODEL	VOLT	OUTLET	LM/HM	Kw	AMP	H x W x L mm	Kg	CODE
DIVER 100M HF*	230v	1¼"	200/28	0.75	6.2	459 x 127 x ---	11.5	022-900
DIVER 200M HF*	230v	1¼"	200/55	1.5	10.8	608 x 127 x ---	15.5	022-904

*End of line

WELL AND BOREHOLE PUMPS

AQUARAIN

E

Aquarain series are suitable for direct installation at the bottom of a tank and used for lifting and pressurising clean water and are capable of distributing pressurised water to domestic installations, small agricultural plants, and sprinkler systems. 20m power cable. Carbon mechanical seal with lip seals. Pump casing, pump head and impellers in 304 stainless steel, 420 stainless steel shaft. Diffusers in glass fibre reinforced noryl. Maximum liquid temperature 35°C. Maximum immersion depth 20m.

Features

High Pressure
High Flow

Applications

Rain Water Systems
Sprinklers
Tanks

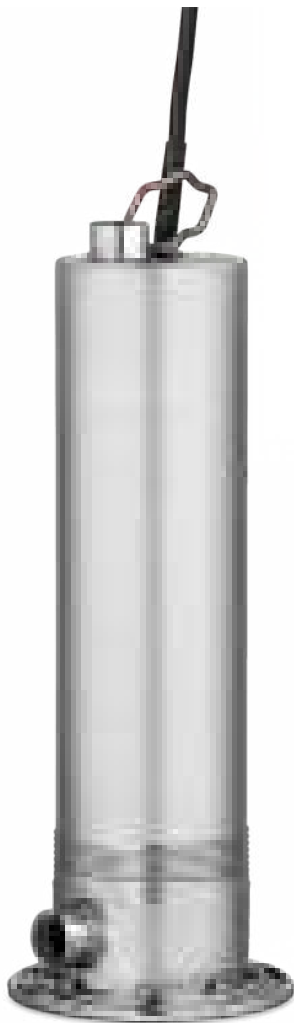
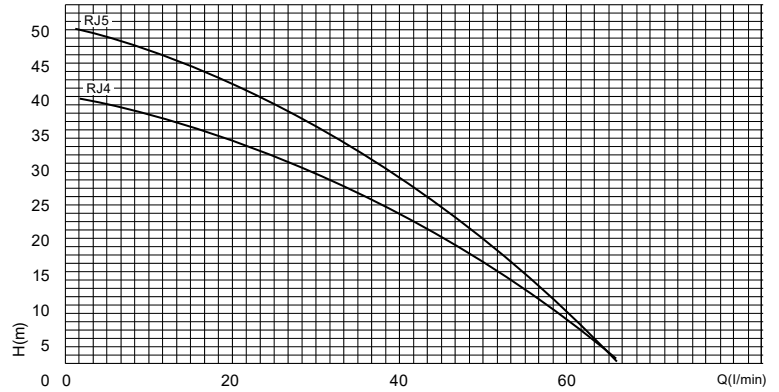

MODEL	VOLT	OUTLET / INLET	LM/HM	Kw	AMP	H x W x L mm	Kg	CODE
AQUARAIN RJ 4.60	230v	1" x 1"	65/40	0.6	3.3	449.5 x 127 x 170	9.6	1200-0282
AQUARAIN RJ 5.60	230v	1" x 1"	65/50	0.6	4.2	469.5 x 127 x 170	9.8	1200-0284
FLOATING FOOTVALVE		1"	-	-	-	-	0.4	060-126

WELL AND BOREHOLE PUMPS

AQUALIJU 5" & 6" HIGH FLOW SUBMERSIBLE PUMPS FOR WELLS

E

Aqualiju series are suitable for use with clean water in domestic, civil and agricultural applications such as the distribution of water in combination with pressure sets, for the irrigation of gardens and allotments and for pressure boosting, etc.. Double mechanical seals. Pump casing, impellers and shaft stainless steel. Maximum liquid temperature 35°C. Power cable 20m. Maximum immersion depth 20m

Features

High Pressure
High Flow

Applications

Rain Water Systems
Sprinklers
Tanks

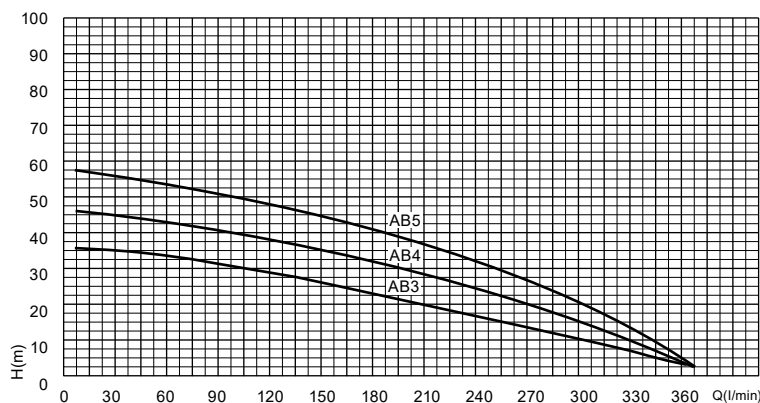
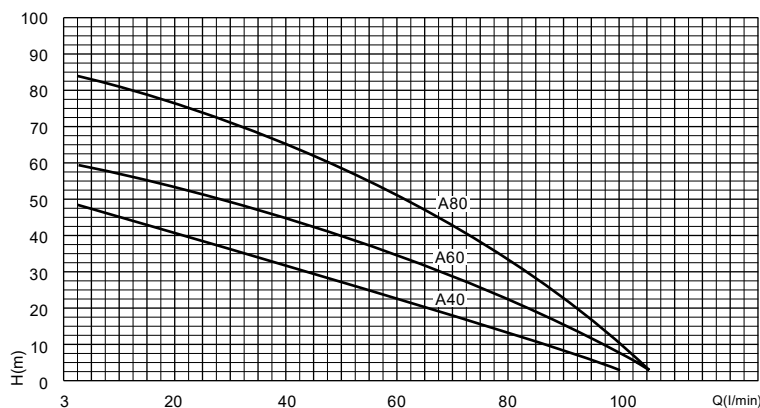

MODEL	VOLT	OUTLET	LM/HM	Kw	AMP	H x W x L mm	Kg	CODE
AQUALIJU A 40.60	230v	1¼"	110/49	0.6	4.6	442 x 130 x - - -	12.5	1200-0200
AQUALIJU A 60.90	230v	1¼"	110/60	0.9	6	481 x 130 x - - -	13	1200-0205
AQUALIJU A 80.130	230v	1¼"	110/84	1.3	8.4	549 x 130 x - - -	16	1200-0210
AQUALIJU AB 3.150	230v	2"	360/34	1.5	11	497 x 152 x - - -	22	1200-0250
AQUALIJU AB 4.220	230v	2"	360/44	2.2	12	546 x 152 x - - -	23	1200-0255
AQUALIJU AB 5.300	400v	2"	360/56	3	4.2	591 x 152 x - - -	25	1200-0260

WELL AND BOREHOLE PUMPS

BOREHOLE MOTOR CAPACITOR/OVERLOAD BOXES

E

Basic borehole motor capacitor and overload boxes. Complete with on and off switch.

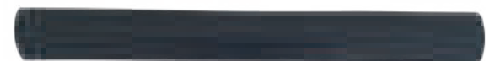

CABLE JOINING KITS See page 237

PHOTOS FOR ILLUSTRATION PURPOSES ONLY

Kw	HP	VOLT	UF SIZE	OVERLOAD	LOW LEVEL CONTROL	Kg	CODE
0.37	0.5	230v	16	4	NO	1	023-546
0.55	0.75	230v	20	7	NO	1	023-548
0.75	1	230v	25	7	NO	1	023-550
1.1	1.5	230v	35	10	NO	1	023-552
1.5	2	230v	40	13	NO	1.5	023-554
2.2	3	230v	60	18	NO	1.5	023-556

WELL AND BOREHOLE PUMPS

4" BOREHOLE MOTORS

E

4" Borehole motors are supplied with a flying lead from the motor to allow for the joining and connection of the required cable. Entirely made of AISI 304 stainless steel for the parts in contact with water. Please see page 237 for cable selection chart, cables and joining kits. If you require capacitor/overload protection please see page 230 and pages 78 & 79 for basic control panels. Standard nema mounting and shafts CCW rotation.

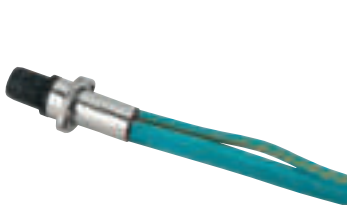

CONNECTOR CABLE

All the 4" borehole motors are supplied with a four core watertight removable cable. Ideal for assembly/disassembly of the motor or pump part.



Top and bottom brackets made from cast iron with nickel plating treatment with a cover made from stainless steel AISI 304 for a full stainless steel appearance.

MODEL	VOLT	Kw	HP	UF SIZE	AMP	H x W x L mm	Kg	CODE
4" MOTOR	230v	0.37	0.5	16	3.3	236 x 96 x ---	6.9	023-400
4" MOTOR	230v	0.55	0.75	20	4.6	266 x 96 x ---	8.1	023-404
4" MOTOR	230v	0.75	1	25	6.2	286 x 96 x ---	9.1	023-408
4" MOTOR	230v	1.1	1.5	35	8.6	331 x 96 x ---	11	023-412
4" MOTOR	230v	1.5	2	40	11	393 x 96 x ---	13.2	023-416
4" MOTOR	230v	2.2	3	60	16	413 x 96 x ---	13.9	023-420
4" MOTOR	400v	0.37	0.5	—	1.4	216 x 96 x ---	6.2	023-402
4" MOTOR	400v	0.55	0.75	—	1.7	236 x 96 x ---	6.9	023-406
4" MOTOR	400v	0.75	1	—	2.1	266 x 96 x ---	8.1	023-410
4" MOTOR	400v	1.1	1.5	—	3.2	286 x 96 x ---	9.1	023-414
4" MOTOR	400v	1.5	2	—	4.1	348 x 96 x ---	11	023-418
4" MOTOR	400v	2.2	3	—	5.9	393 x 96 x ---	13.2	023-422
4" MOTOR	400v	3	4	—	7.9	544 x 96 x ---	19.9	023-424
4" MOTOR	400v	4	5.5	—	10.1	614 x 96 x ---	22.9	023-426
4" MOTOR	400v	5.5	7.5	—	13.9	684 x 96 x ---	26.8	023-428
4" MOTOR	400v	7.5	10	—	16.9	764 x 96 x ---	30.6	023-430

WELL AND BOREHOLE PUMPS

PENTAX 4S/A BOREHOLE CARTRIDGES

E

Submersible multistage centrifugal pumps for 4" wells. Check valve built into the delivery outlet. Pump flange for coupling with motors are made according to NEMA standards. Maximum 35°C water temperature. Select required cartridge, note the Kw required then choose a motor, 230v or 400v from page 231. If you require capacitor/overload protection please see pages 78, 79 & 230.

Features

- Polycarbonate Impellers
- Polycarbonate Diffusers
- Wear Rings in Stainless Steel
- Bronze Upper Bushing

Applications

- 4" Boreholes
- Water Boosting

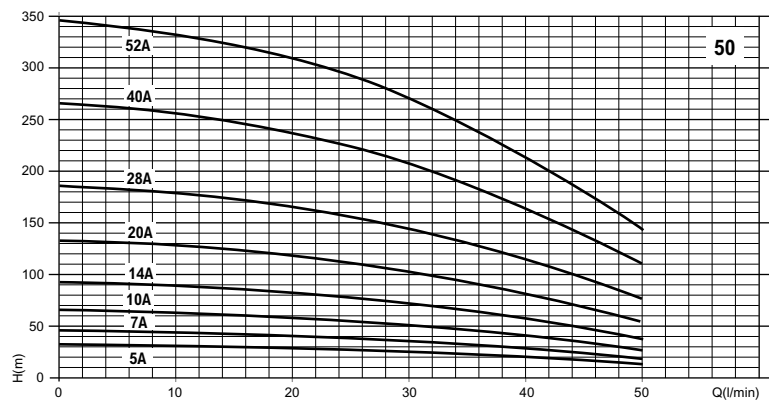
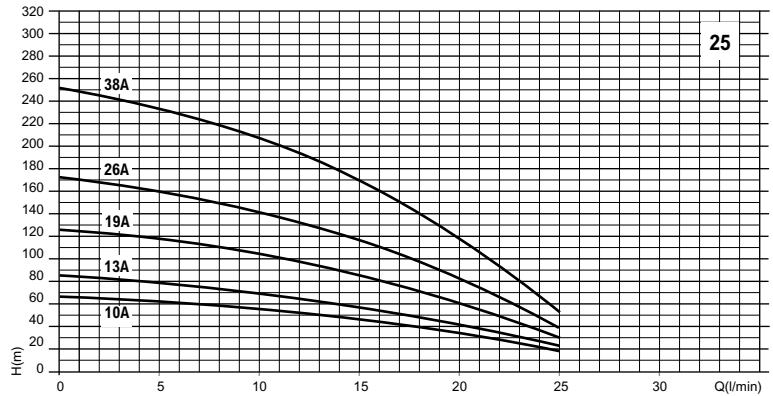
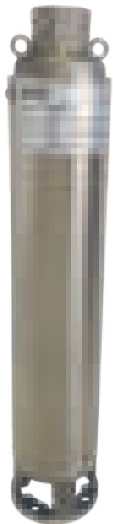

MODEL	Kw	HP	OUTLET	LM/HM	H x W x L mm	Kg	CODE
4S 25/10A	0.37	0.5	1¼"	25/67	324 x 96 x ---	3.3	105-0400
4S 25/13A	0.37	0.5	1¼"	25/86	377 x 96 x ---	3.7	105-0405
4S 25/19A	0.55	0.75	1¼"	25/126	481 x 96 x ---	4.7	105-0410
4S 25/26A	0.75	1	1¼"	25/173	642 x 96 x ---	5.8	105-0415
4S 25/38A	1.1	1.5	1¼"	25/253	864 x 96 x ---	8.2	105-0420
4S 50/5A	0.37	0.5	1¼"	50/33	245 x 96 x ---	2.6	105-0425
4S 50/7A	0.37	0.5	1¼"	50/47	280 x 96 x ---	2.9	105-0430
4S 50/10A	0.55	0.75	1¼"	50/67	332 x 96 x ---	3.5	105-0435
4S 50/14A	0.75	1	1¼"	50/93	402 x 96 x ---	4.2	105-0440
4S 50/20A	1.1	1.5	1¼"	50/133	507 x 96 x ---	5.3	105-0445
4S 50/28A	1.5	2	1¼"	50/187	680 x 96 x ---	7.1	105-0450
4S 50/40A	2.2	3	1¼"	50/267	914 x 96 x ---	10.1	105-0455
4S 50/52A	3	4	1¼"	50/347	1120 x 96 x ---	12.2	105-0460

WELL AND BOREHOLE PUMPS

PENTAX 4S/A BOREHOLE CARTRIDGES

E

Submersible multistage centrifugal pumps for 4" wells. Check valve built into the delivery outlet. Pump flange for coupling with motors are made according to NEMA standards. Maximum 35°C water temperature. Select required cartridge, note the Kw required then choose a motor, 230v or 400v from page 231. If you require capacitor/overload protection please see pages 78, 79 & 230.

Features

- Polycarbonate Impellers
- Polycarbonate Diffusers
- Wear Rings in Stainless Steel
- Bronze Upper Bushing

Applications

- 4" Boreholes
- Water Boosting

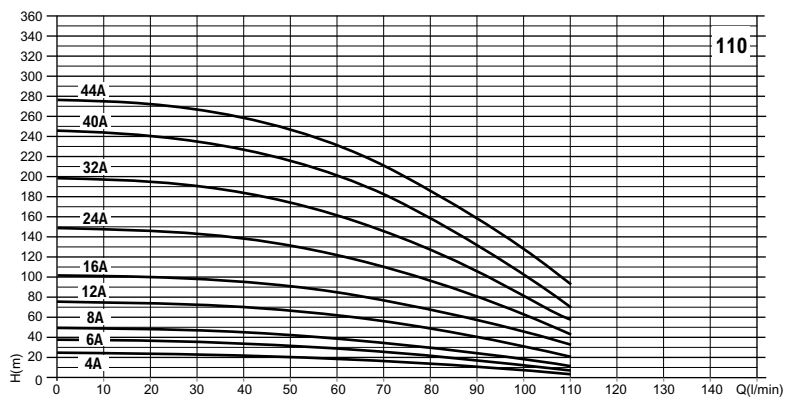
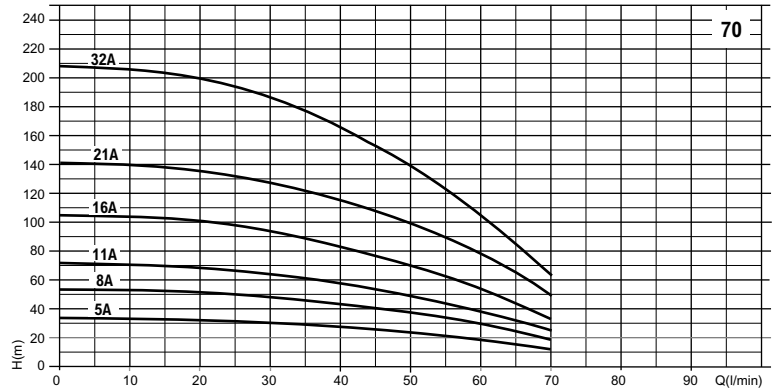

MODEL	Kw	HP	OUTLET	LM/HM	H x W x L mm	Kg	CODE
4S 70/5A	0.37	0.5	1¼"	70/34	236 x 96 x ---	2.5	105-0465
4S 70/8A	0.55	0.75	1¼"	70/54	289 x 96 x ---	2.9	105-0470
4S 70/11A	0.75	1.0	1¼"	70/72	342 x 96 x ---	3.4	105-0475
4S 70/16A	1.1	1.5	1¼"	70/106	430 x 96 x ---	4.2	105-0480
4S 70/21A	1.5	2.0	1¼"	70/142	519 x 96 x ---	5.0	105-0485
4S 70/32A	2.2	3.0	1¼"	70/208	749 x 96 x ---	7.1	105-0490
4S 110/4A	0.37	0.5	1¼"	110/26	247 x 96 x ---	2.4	105-0540
4S 110/6A	0.55	0.75	1¼"	110/38	296 x 96 x ---	2.6	105-0542
4S 110/8A	0.75	1	1¼"	110/51	345 x 96 x ---	3.3	105-0545
4S 110/12A	1.1	1.5	1¼"	110/77	433 x 96 x ---	4.1	105-0550
4S 110/16A	1.5	2	1¼"	110/102	542 x 96 x ---	5	105-0555
4S 110/24A	2.2	3	1¼"	110/151	777 x 96 x ---	6.6	105-0560
4S 110/32A	3	4	1¼"	110/203	965 x 96 x ---	8.7	105-0565
4S 110/40A	3.7/4	5/5.5	1¼"	110/253	1160 x 96 x ---	10.4	105-0570
4S 110/44A	4	5.5	1¼"	110/278	1296 x 96 x ---	11.2	105-0575

WELL AND BOREHOLE PUMPS

PENTAX 4S/A BOREHOLE CARTRIDGES

E

Submersible multistage centrifugal pumps for 4" wells. Check valve built into the delivery outlet. Pump flange for coupling with motors are made according to NEMA standards. Maximum 35°C water temperature. Select required cartridge, note the Kw required then choose a motor, 230v or 400v from page 231. If you require capacitor/overload protection please see pages 78, 79 & 230.

Features

- Polycarbonate Impellers
- Polycarbonate Diffusers
- Wear Rings in Stainless Steel
- Bronze Upper Bushing

Applications

- 4" Boreholes
- Water Boosting

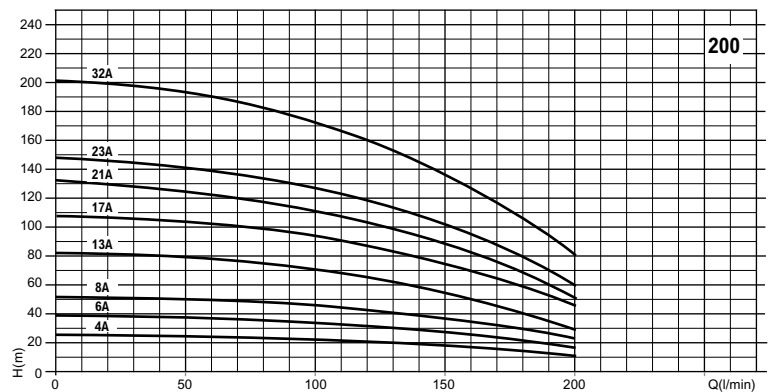
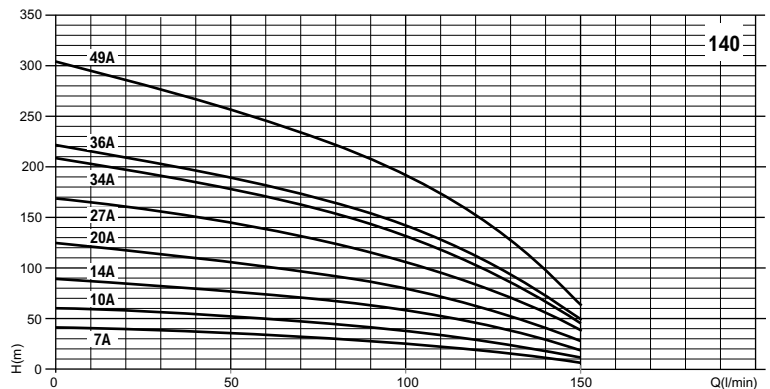
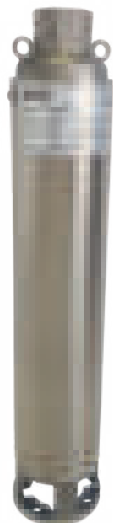

MODEL	Kw	HP	OUTLET	LM/HM	H x W x L mm	Kg	CODE
4S 140/7A	0.75	1.0	2"	140/42	390 x 96 x ---	3.7	105-0580
4S 140/10A	1.1	1.5	2"	140/62	483 x 96 x ---	4.6	105-0585
4S 140/14A	1.5	2.0	2"	140/90	607 x 96 x ---	5.7	105-0590
4S 140/20A	2.2	3.0	2"	140/125	831 x 96 x ---	7.5	105-0595
4S 140/27A	3	4.0	2"	140/169	1048 x 96 x ---	9.6	105-6000
4S 140/34A	3.7/4	5/5.5	2"	140/208	1257 x 96 x ---	11.6	105-0602
4S 140/36A	4	5.5	2"	140/221	1318 x 96 x ---	12.2	105-0605
4S 140/49A	5.5	7.5	2"	140/302	1802 x 96 x ---	15.9	105-0610
4S 200/4A	0.75	1	2"	200/26	294 x 96 x ---	2.8	105-0615
4S 200/6A	1.1	1.5	2"	200/39	356 x 96 x ---	3.4	105-0620
4S 200/8A	1.5	2	2"	200/52	418 x 96 x ---	4	105-0625
4S 200/13A	2.2	3	2"	200/82	573 x 96 x ---	5.5	105-0630
4S 200/17A	3	4	2"	200/108	697 x 96 x ---	6.6	105-0635
4S 200/21A	3.7/4	5/5.5	2"	200/132	859 x 96 x ---	7.8	105-0640
4S 200/23A	4	5.5	2"	200/148	921 x 96 x ---	8.4	105-0645
4S 200/32A	5.5	7.5	2"	200/202	1238 x 96 x ---	11	105-0647

WELL AND BOREHOLE PUMPS

PENTAX 4S/A BOREHOLE CARTRIDGES

E

Submersible multistage centrifugal pumps for 4" wells. Check valve built into the delivery outlet. Pump flange for coupling with motors are made according to NEMA standards. Maximum 35°C water temperature. Select required cartridge, note the Kw required then choose a motor, 230v or 400v from page 231. If you require capacitor/overload protection please see pages 78, 79 & 230.

Features

- Polycarbonate Impellers
- Polycarbonate Diffusers
- Wear Rings in Stainless Steel
- Bronze Upper Bushing

Applications

- 4" Boreholes
- Water Boosting

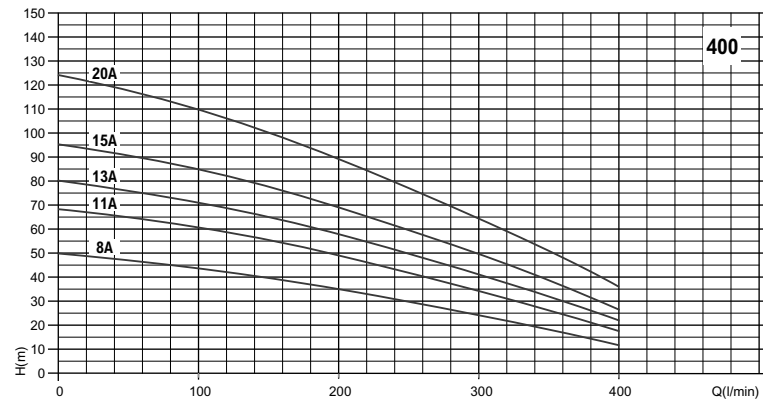
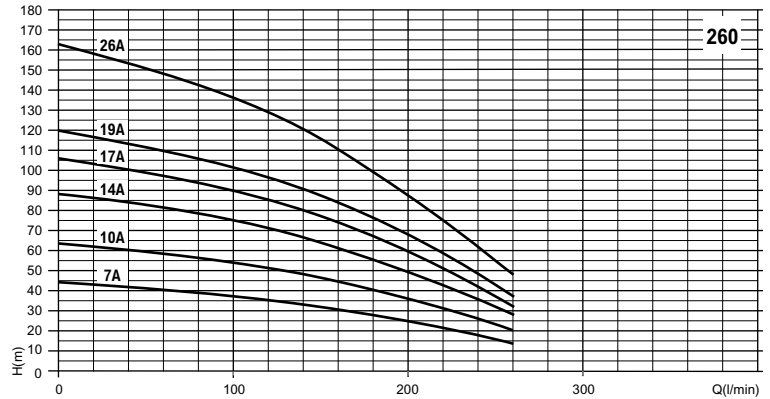
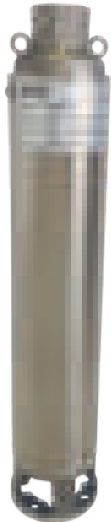

MODEL	Kw	HP	OUTLET	LM/HM	H x W x L mm	Kg	CODE
4S 260/7A	1.5	2.0	2"	260/45	534 x 96 x ---	5.3	105-0650
4S 260/10A	2.2	3.0	2"	260/64	690 x 96 x ---	6.7	105-0655
4S 260/14A	3	4.0	2"	260/89	989 x 96 x ---	8.6	105-0660
4S 260/17A	3.7/4	5/5.5	2"	260/107	1092 x 96 x ---	10.1	105-0665
4S 260/19A	4	5.5	2"	260/120	1195 x 96 x ---	11.0	105-0670
4S 260/26A	5.5	7.5	2"	260/163	1559 x 96 x ---	14.3	105-0675
4S 400/8A	2.2	3	2"	400/51	676 x 96 x ---	6.3	105-0680
4S 400/11A	3	4	2"	400/70	880 x 96 x ---	8.1	105-0685
4S 400/13A	3.7/4	5/5.5	2"	400/81	1013 x 96 x ---	9.3	105-0690
4S 400/15A	4	5.5	2"	400/97	1149 x 96 x ---	10.5	105-0695
4S 400/20A	5.5	7.5	2"	400/125	1489 x 96 x ---	13.5	105-0700

WELL AND BOREHOLE PUMPS

PIPE RESISTANCE CHART GUIDE

FLOW LT/MIN	PIPE SIZE											
	1/2"	3/4"	1"	1 1/4"	1 1/2"	2"	2 1/2"	3"	3 1/2"	4"	5"	6"
30	70	16.5	5.3	1.4	0.7	0.2						
40		28	9	2.3	1.2	0.3						
50		42	13	3.5	1.8	0.5	0.15					
60		58	18	5	3	0.7	0.2					
70		76	24	6.5	3	0.9	0.2	0.1				
80			30	8	4	1.2	0.3	0.16				
90			38	9	5	1.5	0.45	0.23				
100			46	11	6	2	0.5	0.2	0.12			
125			70	17	9	3	0.8	0.3	0.18	0.1		
150				25	12	4	1.2	0.5	0.2	0.14		
175				33	16	6	1.5	0.6	0.33	0.18		
200				42	21	7	2	1	0.4	0.2	0.08	
250				64	32	10	2.8	1.2	0.6	0.3	0.12	
300					45	14	4	2	1	0.45	0.17	
400					78	24	6.8	3	1.5	0.8	0.2	0.12
500						36	11	5	3	1.5	0.5	0.17

BOLD NUMBERS INDICATE EXTRA HEAD CREATED BY PIPE RESISTANCE IN METRES PER 100m RUN

PIPE RESISTANCE CHART EXAMPLES:

300m of 1 1/2" pipe with 70 l/m flow i.e.: at 70 l/m 1 1/2" pipe requires 3m extra head for each 100m.

Therefore 3 x 3m = 9m extra static head.

500m of 2" pipe with 200l/m i.e.: @ 200 l/m 2" pipe = 7m head.

Therefore 7 x 5 = 35m extra static head.

CAPACITORS 440v MOTOR RUN

A

PIN TYPE	CODE	LEAD TYPE	CODE
6uf	-	2uf	072-070
8uf	-	4uf	072-075
10uf	072-092	6uf	072-080
12uf	072-096	8uf	072-085
14uf	072-097	10uf	072-090
16uf	072-102	12uf	072-095
20uf	072-105	14uf	-
25uf	072-112	16uf	072-100
30uf	072-115	20uf	072-106
35uf	072-118	25uf	072-110
40uf	072-120	30uf	072-116
50uf	072-125	35uf	072-117
60uf	072-130	40uf	072-122
70uf	072-135	50uf	-
80uf	072-140	60uf	-
		70uf	-
		80uf	-



WELL AND BOREHOLE PUMPS

CABLE RECOMMENDATION SIZE FOR PUMPS – CABLE SIZE 4 CORE IN MM MAXIMUM LENGTH OF CABLE IN METRES

MOTOR (Kw)	VOLT	1.5mm	2.5mm	4mm	6mm	10mm	16mm
SINGLE PHASE MOTORS							
0.37	230	80	130	230	350	580	1000
0.55	230	55	90	140	200	350	700
0.75	230	40	65	105	160	300	500
1.1	230	30	50	75	115	190	400
1.5	230	25	35	60	90	145	230
2.2	230	–	30	50	70	120	185
3 PHASE MOTORS							
0.37	415	400	500	600	850	1000	1300
0.55	415	315	430	600	700	900	1200
0.75	415	240	350	500	650	750	1000
1.1	415	180	285	350	450	600	900
1.5	415	135	225	360	470	600	900
2.2	415	100	165	255	390	450	700
3	415	65	110	180	255	420	560
4	415	50	85	135	195	330	500
5.5	415	40	70	110	165	270	390
7.5	415	30	55	90	130	220	495

CABLE RESISTANCE EXAMPLES Max volt drop allowed is 2.5% = 6v @ 230v

1.1 Kw motor single phase on 150m of cable,

ie: on 1.1 Kw the maximum you can run is 190m, if you use 10mm.

1.1 Kw motor three phase on 150m of cable,

ie: 1.1 Kw can go up to 180m on 1.5mm cable. Therefore on 10mm it can run up to 600m.

CABLES HO7RNF & JOINTS

A

ITEM - 4 CORE CABLE	CODE	ITEM - 3 CORE CABLE	CODE
CABLE			
1.5 x 4C CABLE	023-510	1.5 x 3C CABLE	023-610
2.5 x 4C CABLE	023-512	2.5 x 3C CABLE	023-612
4.0 x 4C CABLE	023-514	4.0 x 3C CABLE	023-614
6.0 x 4C CABLE	023-516	6.0 x 3C CABLE	023-616
10.0 x 4C CABLE	023-518	10.0 x 3C CABLE	023-620

ITEM	CODE	ITEM	CODE
JOINT KIT EPOXY 2 PART 0.5-4mm	023-520	THERMAL JOINT KIT	023-525
JOINT KIT EPOXY 6-10mm	023-522	UP TO 2.5mm 4 CORE STD	

Cut cable cannot be returned for credit unless sent incorrectly.



2 PART EPOXY CABLE JOINING KIT

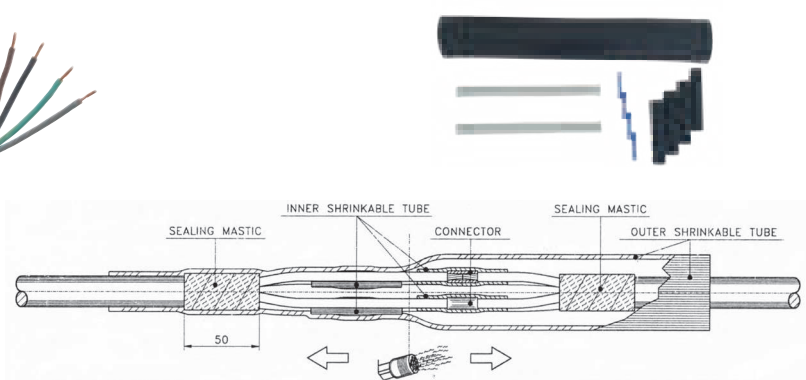

THERMAL CABLE JOINING KIT

PGA self priming liquid ring series designed for diesel transfer. Cast iron pump body and motor bracket, brass impeller, stainless steel shaft and carbon ceramic seal. Maximum recommended suction height 3 metres with suction valve. Delta self priming liquid ring series designed for diesel transfer. Complete with carrying handle, switch and 1.5 metres of cable. Cast iron pump body and motor bracket, brass impeller, stainless steel shaft and carbon ceramic seal. Maximum recommended suction height 3 metres with suction valve. All models are NOT for pumping petrol, chemicals, water and liquids with a low flash point.

Features

Self Priming

Applications

Diesel Transfer

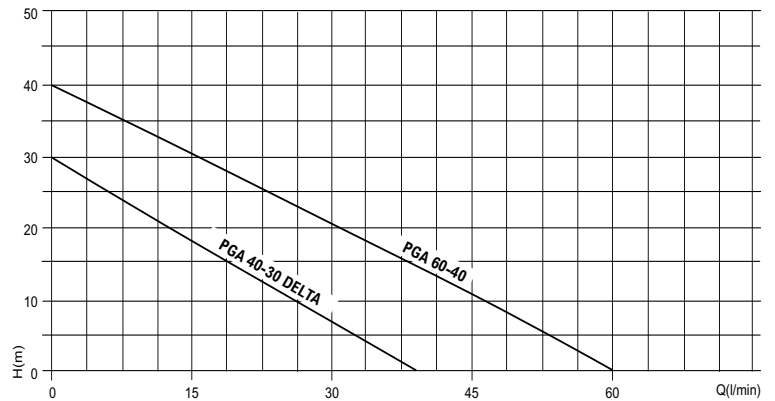

PGA 40-30/60-40



DELTA

MODEL	VOLTAGE	INLET/OUTLET	LM/HM	Kw	AMP	H x W x L mm	Kg	CODE
PGA 40-30	230v	3/4"	40/30	0.55	2.7	141 x 120 x 255	6.2	050-310
PGA 40-30	400v	3/4"	40/30	0.55	0.9	141 x 120 x 255	6.2	050-315
PGA 60-40	230v	1"	60/40	0.9	4.5	148 x 420 x 260	8.0	050-320
PGA 60-40	400v	1"	60/40	0.9	1.6	148 x 420 x 260	8.0	050-325
DELTA	230v	3/4"	40/30	0.55	2.7	141 x 120 x 255	7.0	050-330
DELTA	110v	3/4"	40/30	0.55	6.0	141 x 120 x 255	7.0	050-332

PA self priming rotary vane pumps. Bypass and stainless steel filter incorporated into the cast iron casing. Complete with On/Off switch and 2 metres of power cable. Maximim 50°C liquid temperature. Light Tech have the same features as the PA series but also comes complete with manual trigger nozzle and 4 metres of hose (no suction hose is supplied with this range). All models are NOT for pumping petrol, chemicals, water and liquids with a low flash point.

Features

Self Priming

Applications

Diesel Transfer



PA1 70/PA2 100



LIGHT TECH KIT

MODEL	VOLTAGE	INLET/ OUTLET	LM/HM	Kw	AMP	H x W x L mm	Kg	CODE
PA1 70 (HE-60)	230v	1" x 1"	70/20	550	2.4	250 x 200 x 300	8.0	050-358
PA2 100 (HE100)	230v	1" x 1"	100/25	950	4.1	250 x 200 x 300	13.5	050-360
LIGHT TECH 60 KIT	230v	1" x 1"	60/20	550	2.4	250 x 200 x 300	14.0	050-363
LIGHT TECH 100 KIT	230v	1" x 1"	100/25	950	4.1	250 x 200 x 300	21.0	050-365

FUEL OIL PUMPS

SELF PRIMING TRANSFER PUMPS LOW VOLTAGE

D

CB12, DC Tech & PB1 85 are all self priming rotary vane pump with a built in by pass within the pump body. Maximum suction lift of three metres. Carry handle, on/off switch, suction filter and one metre of battery cable with clips. CB12 has 3/4" BSP inlet and outlet threads and supplied with 3/4" thread to 1" hose tails. CB12 kit also comes with 2 metre suction, 2 metre delivery hose and manual trigger nozzle. All models are NOT for pumping petrol, chemicals, water and liquids with a low flash point.

Features

Self Priming

Applications

Diesel Transfer



CB 12



DC TECH



CB 12 KIT



PB1 85

MODEL	VOLTAGE	INLET/OUTLET	LM/HM	WATTS	AMP	H x W x L mm	Kg	CODE
CB 12*	12v	3/4" x 3/4"	40/10	175	13	150 x 102 x 200	3.8	050-342
DC TECH 40	12v	3/4" x 3/4"	40/13	216	18	140 x 130 x 200	4.4	050-335
DC TECH 40	24v	3/4" x 3/4"	40/13	264	11	140 x 130 x 200	4.4	050-340
PB1 85	12v	1" x 1"	85/24	480	40	190 x 250 x 290	10.0	050-367
PB1 85	24v	1" x 1"	85/24	768	32	190 x 250 x 290	10.0	050-368
CB 12 KIT*	12v	3/4" x 3/4"	40/10	175	13	150 x 102 x 200	5.0	050-344

* 3/4" thread to 1" hose tails supplied

HI TECH 60 self priming vane pump fitted in a panel which can be free standing or wall hung. Integral nozzle holder included. Complete with flow meter, trigger gun, 1" brass male hose tail for the discharge connection, 4 metres of hose to go between pump outlet and trigger gun. No suction hose is supplied with this model. Drum Tech series includes low voltage self priming pump, on/off switch, battery clips, trigger gun, 4 metres hose, metal telescopic suction tube, suction filter, hose connections and 2" bung connection. Designed to be assembled and directly fitted to drums. FD/FA series includes trigger gun, 2 metres hose, metal suction tube, suction filter, 2" bung connection, 5 metres power cable. Comes pre assembled. All models are NOT for pumping petrol, chemicals, water and liquids with a low flash point.

Features

Self Priming

Applications

Diesel Transfer



HI TECH 60



FD/FA DRUM PUMP



DRUM TECH

MODEL	VOLTAGE	INLET/ OUTLET	LM/HM	WATTS	AMP	H x W x L mm	Kg	CODE
HI TECH 60	230v	1" x 1"	60/20	370	1.5	300 x 390 x 390	16	050-298
DRUM TECH DC 12	12v	1" x 1"	40/13	252	21	1200 x 130 x 200	10.0	050-290
DRUM TECH DC 24	24v	1" x 1"	40/13	312	13	1200 x 130 x 200	10.0	050-292
FD-12	12v	1" x 1"	40/6	80	14	1228 x 291 x 172	10.0	050-215
FD-24	24v	1" x 1"	50/7	90	7	1228 x 291 x 172	10.0	050-220
FA-100	230v	1" x 1"	50/7	100	1	1228 x 291 x 172	10.0	050-225
FA-100	110v	1" x 1"	50/7	100	2.0	1228 x 291 x 172	10.0	050-227

SELF PRIMING CONTRACTOR PUMPS

FUEL OIL 'RED' COMPLETE WITH ATEX MOTOR

B

Self priming electric pump with flame proof motor for the transfer of fuels. Open impeller suitable for pumping diesel, gas oil, paraffin. NOT FOR PUMPING PETROL. A non-return valve is fitted on the inlet of the pump body to avoid the loss of liquid after the pump has stopped, making it easier to prime when the pump starts again. Maximum suction depth of 6 metres and a maximum liquid temperature of 60°C. Pump casing, inlet flange and impeller are made from cast iron. Stainless steel shaft. Viton mechanical seal and Viton check valve. Manufactured in accordance with standards ATEX 94/9/CE. (II 2G Ex d IIC T4) For flow curves see page 140.

Features

Centrifugal
Self Priming
Atex

Applications

Diesel Transfer



ATEX 94/9/CE
II 2G EX d IIC T4

MODEL	VOLTAGE	INLET/ OUTLET	LM/HM	Kw	AMP	SOLIDS	H x W x L mm	Kg	CODE
B1½KQA RED EAZ3*	230v	1½" x 1½"	290/16	0.75	4.8	8mm	300 x 255 x 495	16	070-EAZ3
B2KQA RED EA9D*	230v	2" x 2"	450/18	1.5	9.1	16mm	300 x 280 x 520	27	070-EA9D
B3KQA RED EA9E*	230v	3" x 3"	850/15	2.2	13.1	27mm	300 x 280 x 550	50	070-EA9E
B1½KQA RED 2140*	400v	1½" x 1½"	290/16	0.75	1.8	8mm	300 x 255 x 495	40	070-2140
B2KQA RED 2141*	400v	2" x 2"	450/18	1.5	4.5	16mm	300 x 280 x 520	27	070-2141
B3KQA RED 2138*	400v	3" x 3"	850/15	2.2	4.8	27mm	300 x 280 x 550	50	070-2138
B3XR-A RED 2139*	400v	3" x 3"	1200/26	4	7.8	19mm	400 x 335 x 685	112	070-2139

*Available upon request.

SELF PRIMING CONTRACTOR PUMPS

FUEL OIL 'RED' HIGH VOLUME DIESEL TRANSFER

B

Self priming electric pump with open impeller to transfer fuels. Suitable for pumping diesel, gas oil, paraffin. NOT FOR PUMPING PETROL. A non-return valve is fitted on the inlet of the pump body to avoid the loss of liquid after the pump has stopped, making it easier to prime when the pump starts again. Maximum suction depth of 6 metres and a maximum liquid temperature of 60°C. Pump casing, inlet flange and impeller are made from cast iron. Stainless steel shaft. Viton mechanical seal and Viton check valve. For flow curves see page 138.

Features

Centrifugal
Self Priming

Applications

Diesel Transfer



MODEL	VOLTAGE	INLET/ OUTLET	LM/HM	Kw	AMP	SOLIDS mm	H x W x L mm	Kg	CODE
B1KQ-A RED EA2L	230v	1" x 1"	140/12	0.55	4.1	7	285 x 216 x 375	15	070-168
B1½KQ-A RED 3516	230v	1½" x 1½"	290/16	0.75	6.2	8	300 x 180 x 375	20	070-3516
B2KQ-A RED EA2V	230v	2" x 2"	450/18	1.5	9	12	300 x 185 x 410	21	070-166
B2KQ-A RED EAHA	110v	2" x 2"	390/16	1.5	19	14	300 x 185 x 410	25	070-159
B3KQ-A RED EA9C	230v	3" x 3"	850/15	2.2	13	27	300 x 185 x 445	30	070-EA9C
B1KQ-A RED EA2M	400v	1" x 1"	140/12	0.55	1.8	7	285 x 216 x 375	15	070-169
B1½KQ-A RED 3501	400v	1½" x 1½"	290/16	0.75	1.9	8	300 x 180 x 375	20	070-163
B2KQ-A RED EA1S	400v	2" x 2"	450/18	1.5	2.6	12	300 x 185 x 410	21	070-167
B3KQ-A RED EAM7	400v	3" x 3"	850/15	2.2	5	27	300 x 185 x 445	30	070-165
B3XR-A RED EANS	400v	3" x 3"	1200/26	4	7.8	35	400 x 280 x 635	74	070-EANS

SURFACE MOUNTED PUMPS

KOSHIN GEAR PUMPS GC & GL SERIES

D

GC series with pulley for transferring light oil, machine oil and heavy oil. GL series are suitable for low viscosity machine and light oil. Also has a by pass function which protects the pump. Both models are NOT for pumping petrol, chemicals, water and products with a low flash point.

Features

GC Heavy Liquids

GL Light Liquids

Applications

Machine Oil

Light Oil

Heavy Oil



KOSHIN GC



KOSHIN GL

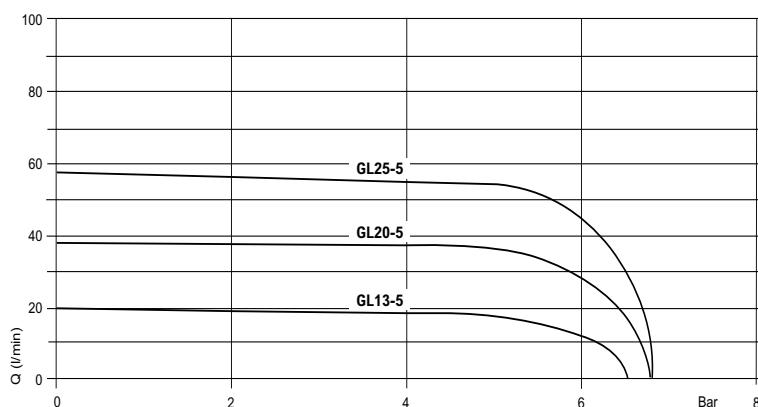
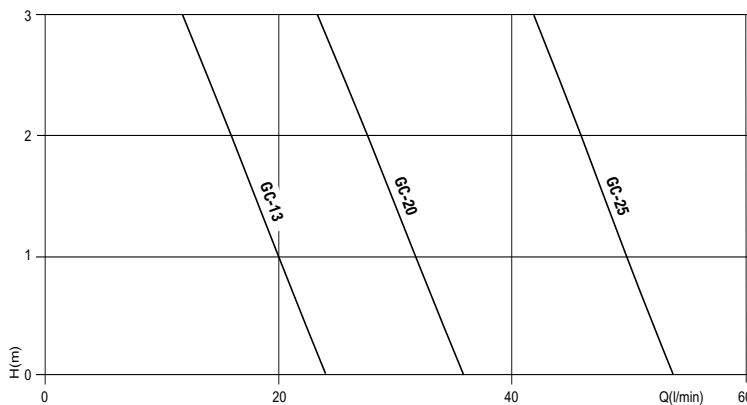

MODEL	PULLEY	INLET/OUTLET	LM @ 200 RPM	LM @ 400 RPM	LM @ 600 RPM	BAR	Kw	H x W x L mm	Kg	CODE
GC13	125 x A1	½" x ½"	10	21	32	1-3	0.2	211 x 283 x 316	4.4	050-410
GC20	150 x A1	¾" x ¾"	18	37	56	1-3	0.4	194 x 262 x 492	6.3	050-414
GC25	200 x A1	1" x 1"	27	55	83	1-3	0.75	265 x 277 x 397	5.7	050-416
MODEL	PULLEY	INLET/OUTLET	LM @ 1450 RPM			BAR	Kw	H x W x L mm	Kg	CODE
GL13-5	BARE	½" x ½"	17			5	0.4	170 x 160 x 234	6	050-440
GL20-5	BARE	¾" x ¾"	29			5	0.8	170 x 160 x 234	7	050-444
GL25-5	BARE	1" x 1"	46			5	1.5	170 x 160 x 234	8	050-448

AD BLUE PUMPS

CDI-H27 AD BLUE PUMPS

D

CDI-H27 pumps are a five chamber positive displacement diaphragm pump with a built in bypass within the pump body. Maximum suction lift 2 metres. All models have on/off switches, Designed for pumping AD Blue (AUS32-DEF-ADBLUE) with no solid suspended particles, fibres or abrasive materials. NOT for pumping petrol. Low voltage models have a duty cycle of approx 20 minutes in every hour. Complete with 1.5 metres of power cable and UK plug on the 230v model. Battery clamps for low voltage models. IP54. 1" hose tails / 1" - 3/4 hose tails supplied.

Features

Self Priming

Applications

AD Blue Transfer



MODEL	VOLTAGE	OUTLET	LM/HM	H x W x L mm	Kg	CODE
CDI-H27	12v	1"	30/10	130 x 130 x 292	4.8	050-560
CDI-H27	24v	1"	30/10	130 x 130 x 292	4.8	050-562
CDI-H27	230v	1"	40/10	160 x 130 x 295	4.8	050-561

FUEL OIL PUMP ACCESSORIES

ACCESSORIES – FUEL OIL HOSE

D

Medium Duty Suction Blue oil hose is a flexible medium duty suction and delivery hose of industrial oils. Shock resistant reinforced PVC spiral. Blue oil resistant covered PCV/Nitrile. Sold per metre. 10°C to +60°C. Oil Suction & Delivery Heavy Duty Hose, reinforced textile with two helix wires embedded with antistatic copper wire. -40°C to +90°C.



MDS BLUE



OSD HEAVY DUTY

TYPE	SIZE	WORKING BAR	BURST BAR	Kg PER METRE	CODE
MDS BLUE	¾"	9	30	0.36	050-370
MDS BLUE	1"	9	25	0.48	050-372
MDS BLUE	1¼"	8	20	0.58	050-374
MDS BLUE	1½"	8	20	0.67	050-376
MDS BLUE	2"	7	18	0.98	050-378
MDS BLUE	3"	6	15	1.7	050-380
OSD HEAVY DUTY	¾"	10	30	0.6	050-382
OSD HEAVY DUTY	1"	10	30	0.65	050-384
OSD HEAVY DUTY	1¼"	10	30	0.84	050-386
OSD HEAVY DUTY	1½"	10	30	1.1	050-388
OSD HEAVY DUTY	2"	10	30	1.5	050-390
OSD HEAVY DUTY	3"	10	30	2.4	050-392

FUEL OIL PUMP ACCESSORIES

ACCESSORIES

D

Standard aluminium trigger gun (Pit Tech) with 1" female swivel fitting. Maximum capacity 100 litres. Maximum pressure 3.5 bar. Auto trigger gun dispensing nozzle with a full tank automatic stop device, ideal for fast and safe refuelling. Aluminium swivel fitting. 60 litres maximum a minute. Techflow 3C a mechanical meter for a high precision measuring of diesel fuel for private use. It is fitted with a totaliser and a partial counter, a side knob for resetting, the fuel outlet direction to be adjusted accordingly. Flow rate 20-120 l/min. Fuel oil presscontrol equipped with a special NBR diaphragm for use with fuel oil. It can be energized with either 115v or 230v. Starts and stops the pump depending on opening and closing of the taps. Stops the pump in case of a liquid shortage and protects it from dry running.

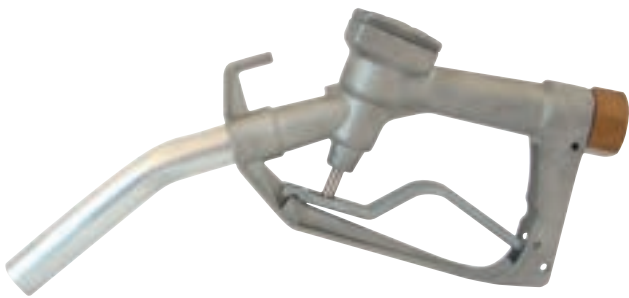

STD TRIGGER GUN



**TECHFLOW 3C
FUEL OIL COUNTER**



AUTO TRIGGER GUN



PRESSCONTROL GAS-OIL

MODEL	HOSE	SIZE	Kg	CODE
STD TRIGGER GUN	–	1"	0.6	050-300
AUTO TRIGGER GUN	–	1"	1.4	050-302
FUEL OIL COUNTER (2.5 BAR MAX)	–	1"	2.17	050-355
FUEL OIL PRESSCONTROL 110/230v	–	1"	1.4	050-304
DIESEL SUCTION KIT INC STRAINER	4 METRES	3/4"	0.72	050-352
DIESEL SUCTION KIT INC STRAINER	4 METRES	1"	0.81	050-352B
DIESEL DISCHARGE KIT HOSE & GUN AUTO	4 METRES	3/4"	4.17	050-350 AUTO
DIESEL DISCHARGE KIT HOSE & GUN MAN	4 METRES	3/4"	4.17	050-350 MAN
DIESEL DISCHARGE KIT HOSE & GUN AUTO	4 METRES	1"	4.17	050-350B AUTO
DIESEL DISCHARGE KIT HOSE & GUN MAN	4 METRES	1"	5.15	050-350B MAN

HAND PUMPS

SEMI ROTARY HAND PUMPS

D

Semi rotary hand pumps are suitable for the handling of clean and light liquids such as water, petrol, diesel, alcohol and light chemical solutions. Pump casing in cast iron and internal parts in brass. Steel shaft and wooden handle. This manual transfer pump is available in a number of sizes with different flow rates. The back plate has lugs for easy mounting and removable inlet/outlet flanges.



MODEL	INLET/OUTLET	AVERAGE LITRES PER CYCLE	AVERAGE LITRES PER MIN	Kg	CODE
K0	½"	0.17	11	6	050-500
K1	¾"	0.34	20	7	050-502
K2	1"	0.66	40	9	050-504
K3	1¼"	0.85	50	12	050-506
K4	1¾"	1.4	85	13	050-508
K5	1½"	1.6	98	16	050-510

HAND PUMPS

HAND PUMPS

D

S-25 suitable for small oil containers. Made from zinc plated steel. RP-94 – c/w 2" bung adapter. Cast iron body with stainless inlet/outlet tubing. Ideal for heavy oils, machine oils and non-corrosive liquids. RP-96 – c/w 2" bung adapter. All polypropylene plastic, hand rotary pump. Suitable for pumping most chemicals. Teflon seal. RP-98 – c/w 1½" and 2" bung adapter. Polypropylene pump body, Teflon seal, stainless steel tubes. Used for diesel oil, corrosive and volatile chemicals, edible liquids (juices, milk, wine, water). RP-88 – c/w 2" bung adapter. Versatile drum pump offers a varied application for oil from low viscosity fluids such as diesel to heavy crude and machine oil. Not for waste oil containing debris or chemical pumping.

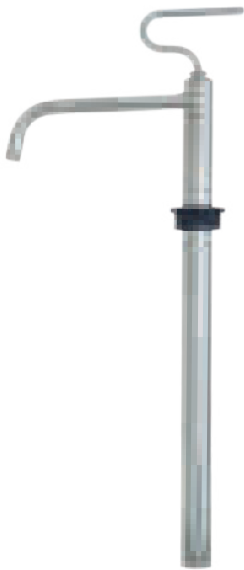

S-25



RP-94



RP-96



RP-98



RP-88

MODEL	OPERATION	LENGTH OF TUBE	LITRES	Kg	CODE
S-25	HAND RECIPROCATING	1 PART TUBE 500mm	0.2/STROKE	1	050-200
RP-94	HAND ROTATING	3 PART TUBE 1000mm	0.3 PER REV	6	050-210
RP-96	HAND ROTATING	3 PART TUBE 1000mm	0.3 PER REV	2	050-212
RP-98	HAND ROTATING	3 PART TUBE 1000mm	0.3 PER REV	3	050-214
RP-88	HAND ROTATING	1 PART TUBE 1000mm	0.9 PER REV	6	050-204

SURFACE MOUNTED PUMPS

FLEXIBLE IMPELLER PUMPS

C

Flexa and Utility are flexible impeller pumps. Supplied with Nitrile oil resistant rubber as standard. Neoprene impeller Versions available for the Utility models only. Flexa and Utility 20 have rapid self-priming up to 2 metres, Utility 40, 3 metres and the Utility 80, 4 metres. Pump body made from bronze, carbon ceramic mechanical seal. Service kits for the utility pumps include impeller, mechanical seal and gasket/o ring.



FLEXA

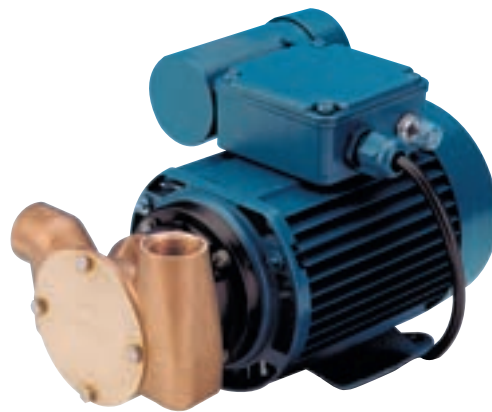

UTILITY

MODEL	VOLTAGE	INLET/ OUTLET	LM/HM	Kw	AMPS	H x W x L mm	Kg	CODE
FLEXA	230v	½" x ½"	25/20	0.37	2.5	185 x 180 x 265	9.5	014-166
UTILITY 20	230v	¾" x ¾"	18/15	0.18	1.6	171 x 170 x 275	7.1	014-153
UTILITY 40	230v	1" x 1"	30/15	0.25	2.8	240 x 210 x 300	10.5	014-157
UTILITY 80	230v	1½" x 1½"	80/16	0.55	4.0	234 x 142 x 323	17	014-159
UTILITY 40	110v	1" x 1"	30/15	0.25	6.5	222 x 182 x 300	10.5	014-167
UTILITY 80	110v	1½" x 1½"	80/16	0.55	8.6	234 x 142 x 323	17	014-156

PART	CODE
UTILITY 20 IMPELLER	014-168
UTILITY 40 IMPELLER	014-163
UTILITY 80 IMPELLER	014-165
FLEXA IMPELLER	9396
UTILITY 20 SERVICE KIT	014-174
UTILITY 40 SERVICE KIT	014-176
UTILITY 80 SERVICE KIT	014-178



UTILITY IMPELLER



FLEXA IMPELLER

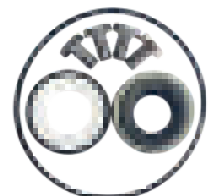

UTILITY SERVICE KIT

HAND PUMPS

PATAY HAND PUMPS

D

The Challenger Drum Pump is made from strong polypropylene and a strong operating rod. Only plastic parts come into contact with the liquid, allowing a range of fluids to be transferred. Each version is supplied with a 2" (59mm) Trisure Drum fitting, which is suitable for most applications. Accessories included are hose outlet and a tap fitting. A 500mm extension tube is available which can be screwed on to the existing tube which then allows it to be suitable for 200 litre barrels.



CHALLENGER



SD-60



BE-45

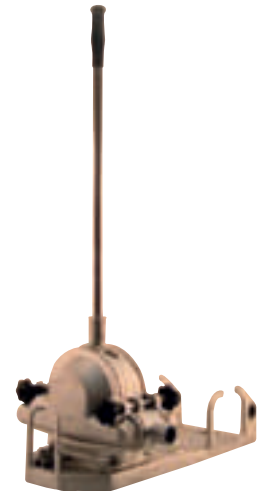

DD-SITE

SD60 – Lightweight design, constructed with strong aluminium handle and can be bench or wall mounted. Can handle solids and can be used for water, oils and diesel. SD-60 CHEM. Chemical pump, suitable for many applications including nitric acid (20%), sodium hypochlorite and white spirit. For other applications please ask to see the chemical compatibility chart. Splash guard fitted, hastalloy internal parts. 1" BSP male ports. BE-45 – Barrel emptying hand pump. Single action diaphragm pump designed to fit oil barrels. Comes complete with barrel bung, two-piece riser tube, suitable for 25 or 250 litre barrels. DD70-120 – High flow double diaphragm. Used in the construction and marine industry. Suction lift of up to 6 metres. Cast aluminium construction. Nitrile diaphragms fitted as standard but can be supplied with higher Aceto Nitrile diaphragms, specifically for pumping diesel at extra cost. Site models come complete with foot plate.

MODEL	OPERATION	LITRES	LENGTH OF TUBE	Kg	CODE
CHALLENGER NITRILE	HAND RECIPROCATING	0.25/STROKE	500mm	1.5	050-180
CHALLENGER VITON	HAND RECIPROCATING	0.25/STROKE	500mm	1.5	050-182
EXTENSION TUBE	–	–	500mm	1	050-184
MODEL	OPERATION	LM/HM	DIAPHRAGM	Kg	CODE
SD-60	HAND RECIPROCATING	60/4.5	SINGLE NITRILE	2	050-186
SD-60 CHEM	HAND RECIPROCATING	60/4.5	SINGLE VITON	2	050-187
BE-45	HAND RECIPROCATING	45/4.5	SINGLE NITRILE	2.6	050-188
DD-70C	HAND RECIPROCATING	70/4.5	DOUBLE NITRILE	3	050-190
DD-100C	HAND RECIPROCATING	100/4.5	DOUBLE NITRILE	3	050-191
DD-120C	HAND RECIPROCATING	120/4.5	DOUBLE NITRILE	4.5	050-192
DD-100B SITE	HAND RECIPROCATING	100/4.5	DOUBLE NITRILE	4.9	050-194
DD-120B SITE	HAND RECIPROCATING	120/4.5	DOUBLE NITRILE	6.4	050-196

SURFACE MOUNTED PUMPS

ELECTRIC DIAPHRAGM PUMP MULTI PURPOSE

D

PVM electric diaphragm pumps have special advantages of pumping liquids containing particles of solid matter in suspension including sand, mud, stones, saw dust, seeds, sludge, hairs and cotton are just a few examples. Can run dry and prime from dry. As this pump is of the volumetric type, the outlet pipe must not be reduced in size, in addition, taps, valves that regulate the flow must not be used on the delivery or suction hose. Supplied as standard with nitrile rubber diaphragm and check valves, upon request they can be supplied as viton at additional cost. 1½” hose inlet/1½” hose outlet. Common spares are also listed below.



MODEL	VOLTAGE	INLET / OUTLET	LM/HM	Kw	AMPS	H x W x L mm	Kg	CODE
PVM	12v	1½” x 1½”	70/5	0.37	31	370 x 250 x 480	25	050-276
PVM	24v	1½” x 1½”	70/5	0.37	18	370 x 250 x 480	25	050-278
PVM	230v	1½” x 1½”	70/5	0.37	2.6	370 x 250 x 480	25	050-270
PVM	110v	1½” x 1½”	70/5	0.37	6.0	370 x 250 x 480	25	050-272
PVM	400v	1½” x 1½”	70/5	0.37	1.1	370 x 250 x 480	25	050-274
COMMON SPARE PARTS			CODE					
MAIN DIAPHRAGM			PVM 0.5-10					
UPPER DIAPHRAGM			PVM 0.5-11					
INLET/OUTLET VALVE			PVM 0.5-4					
INLET FITTING			PVM 0.5-3					
OUTLET FITTING			PVM 0.5-7					
INLET/OUTLET CLAMP			PVM 0.5-8					



SURFACE MOUNTED PUMPS

SELF PRIMING REVERSING PUMPS

D

Self-priming liquid ring pump, with star geometry impeller, equipped with a double direction of rotation as standard and a high efficiency motor calculated to operate in continuous service. The particular hydraulic geometry allows the pump to work even in the presence of air bubbles in the suction liquid. Bronze pump bodies and brass impellers. BSP threads. Clean liquids only with no solids or abrasives. Examples of use include water, wine, milk, vinegar, low viscosity oily solutions, neutral fluid detergents and diesel. Model BE-25F comes complete in a heavy duty carry frame ideal for hire and site conditions. All models come with brass hose tails except model BE-20 which is plastic.

Features

Self Priming
Reversing
Various Duties

Applications

Diesel Transfer
Hire



BE-M25



BE-M25F

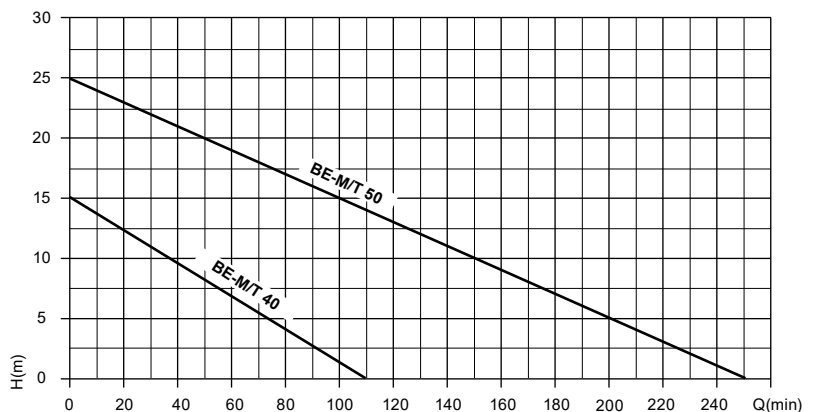
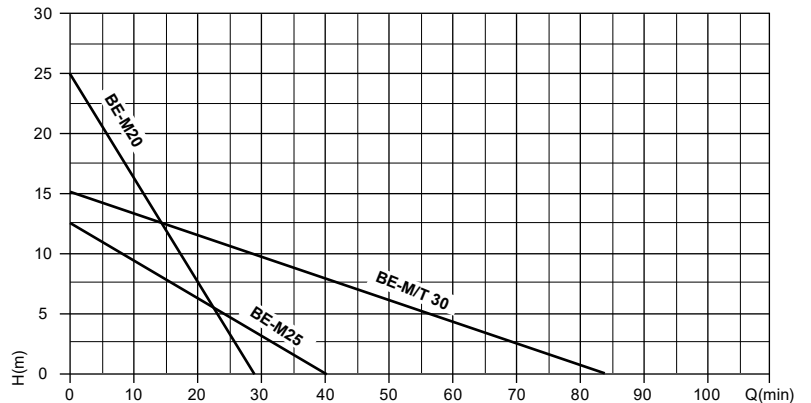

MODEL	VOLTAGE	INLET/OUTLET	LM/HM	Kw	AMPS	H x W x L mm	KG	CODE
BE-M20	230v	3/4" x 3/4"	28/25	0.34	1.8	190 x 120 x 230	5	1300-0020
BE-M25	230v	1" x 1"	40/12	0.42	2.3	190 x 120 x 250	6	1300-0025
BE-M25F	230v	1" x 1"	40/12	0.42	2.3	280 x 300 x 370	11	1300-0027
BE-M30	230v	1 1/4" x 1 1/4"	83/15	0.65	3.7	210 x 150 x 310	10	1300-0030
BE-M40	230v	1 1/2" x 1 1/2"	108/15	0.8	4.0	210 x 150 x 320	11	1300-0040
BE-M50	230v	2" x 2"	250/25	2.1	11.0	240 x 170 x 400	22	1300-0050
BE-T30	400v	1 1/4" x 1 1/4"	83/15	0.65	1.5	210 x 150 x 310	10	1300-0035
BE-T40	400v	1 1/2" x 1 1/2"	108/15	0.08	3.0	210 x 150 x 320	11	1300-0045
BE-T50	400v	2" x 2"	250/25	2.1	5.1	240 x 170 x 400	22	1300-0055

SURFACE MOUNTED PUMPS

DIESEL & OIL TRANSFER PUMP

D

Volumetric electric pump with eccentric rotor to transfer low flow diesel fuel and oil, consisting of a self-ventilated single-phase motor fitted with thermal protection inserted in the winding. The acetal resin rotor is placed within the aluminium pump body, ensuring a reliable performance with oils up to 700 cSt. Suction filter provided. Flow rate is dependant on oil thickness but can be as much as 30 litres per min. 2 metre suction height. Complete with internal by pass, suction filter, on/off switch and 2 metres of power cable. 3/4" bsp outlet, supplied with 3/4" - 1" hose barbs. Care should be taken when pumping thicker oil as the run time of the motor decreases to 30 mins maximum

Features

Self Priming

Applications

Diesel Transfer
Oil Transfer

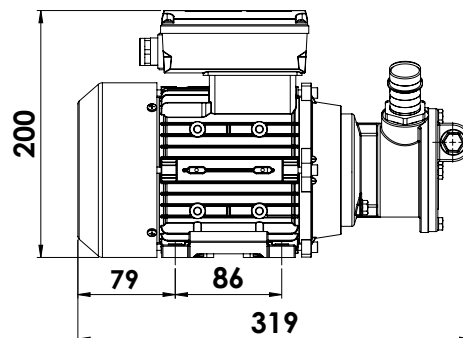
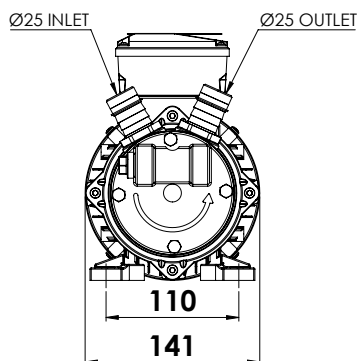
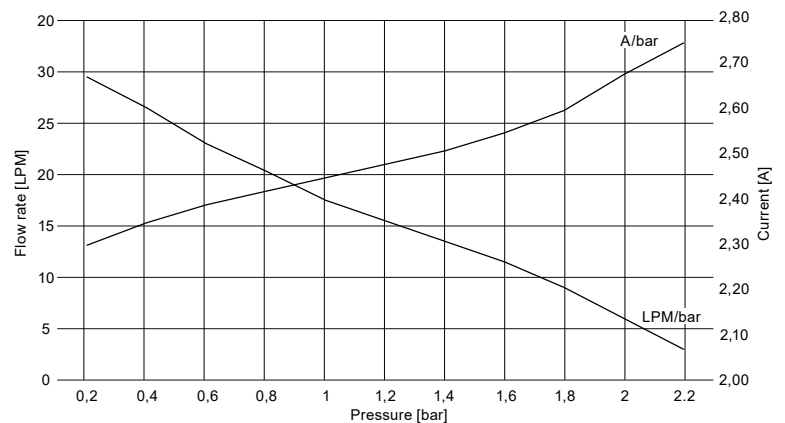

MODEL	VOLTAGE	OUTLET	LM/HM	Kw	AMP	H x W x Lmm	KG	CODE
E220	230v	3/4" BSP / 1" HOSE	30/35	0.85 / 0.92	3.7 / 4.0	200 x 141 x 319	9.8	050-494

SURFACE MOUNTED PUMPS

SELF PRIMING REVERSING PUMPS LOW VOLTAGE

D

Self-priming liquid ring pump, with star geometry impeller, Can pump in either direction by swapping the positive and negative supply cables. The particular hydraulic geometry allows the pump to work even in the presence of air bubbles in the suction liquid. Bronze pump bodies and brass impellers. BSP threads. Clean liquids only with no solids or abrasives. Examples of use include water, wine, milk, vinegar, low viscosity oily solutions, neutral fluid detergents and diesel. Maximum liquid temperature 35°C. Low voltage motors have brushes and a cycle duty of approximately twenty minutes in every hour.

Features

Self Priming
Reversing
Various Duties

Applications

Diesel Transfer
Hire

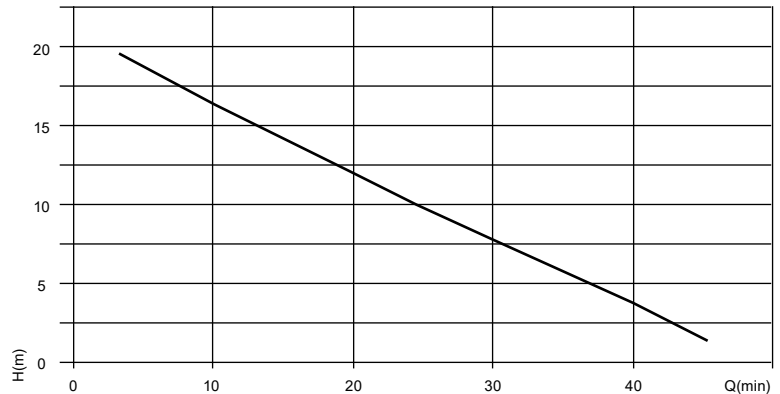

MODEL	VOLTAGE	INLET/OUTLET	LM/HM	Kw	AMPS	H x W x L mm	KG	CODE
MARINA 25	12v	1" x 1"	40/24	0.36	30	190 x 120 x 230	7	1300-0010
MARINA 25	24v	1" x 1"	50/24	0.38	15	190 x 120 x 230	7	1300-0015

SURFACE MOUNTED PUMPS

GEAR PUMPS

D

Volumetric self priming gear pumps with built in bypass valve. Performances will vary depending on media being pumped Declared performances have been obtained pumping liquids with a viscosity of 8° Engler. Maximum viscosity for the gear pumps is up to 10° Engler. For higher viscosities of more than 10° Engler 6 pole motors are available as special orders. Maximum self priming depth 3 metres. Viton mechanical seal. Bypass is adjustable between 0-10 bar. Casing made from cast iron, gears made from C40 steel. 4 pole 1440 rpm motors. Suitable for pumping viscous liquids without suspended particles – hydraulic oil, vegetable oil, diesel fuel oil, varnishes and foodstuffs are examples. Not suitable for liquids that have water within them. Gear pumps are available in bronze. Bronze pump casing, gears made from AISI 316 stainless steel. For special orders they can be made in all AISI 316 stainless steel upon request.

Features

High Pressure
Self Priming

Applications

Hydraulic Oil
Diesel Fuel



MODEL	VOLTAGE	INLET / OUTLET	LM/HM	Kw	AMPS	H x W x L mm	Kg	CODE
GEAR 300GM-GE03	230v	½" x ½"	5/100	0.26	1.8	210 x 170 x 390	11	050-462
GEAR 600GM-GE09	230v	¾" x ¾"	10/100	0.37	2.8	210 x 170 x 410	14	050-466
GEAR 1000GM-GE15	230v	¾" x ¾"	16/100	0.55	4.5	210 x 170 x 450	15	050-470
GEAR 1500GM-GE21	230v	¾" x ¾"	25/100	0.75	5.7	210 x 170 x 460	18	050-474
GEAR 2000GM-GE27	230v	1" x 1"	33/100	1.10	6.0	210 x 170 x 465	22	050-478
GEAR 3000GM-GE33	230v	1" x 1"	50/100	1.50	10.0	210 x 170 x 525	24	050-482
GEAR 3600GM-GE39	230v	1¼" x 1¼"	60/100	1.80	13.0	210 x 170 x 525	28	050-486
GEAR 300GT-GE04	400v	½" x ½"	5/100	0.26	0.8	210 x 170 x 390	11	050-464
GEAR 600GT-GE10	400v	¾" x ¾"	10/100	0.37	1.2	210 x 170 x 410	14	050-468
GEAR 1000GT-GE16	400v	¾" x ¾"	16/100	0.55	2.0	210 x 170 x 450	15	050-472
GEAR 1500GT-GE22	400v	¾" x ¾"	25/100	0.75	2.0	210 x 170 x 460	18	050-476
GEAR 2000GT-GE28	400v	1" x 1"	33/100	1.10	2.8	210 x 170 x 465	22	050-480
GEAR 3000GT-GE34	400v	1" x 1"	50/100	1.50	4.0	210 x 170 x 525	24	050-484
GEAR 3600GT-GE40	400v	1¼" x 1¼"	60/100	1.80	5.0	210 x 170 x 525	28	050-488

SURFACE MOUNTED PUMPS

MONO M RANGE

B

Applications include – cellar drainage, septic/cess pit emptying, garden sprinkler and irrigation systems, water supply, diesel transfer, vegetable oil and non-aggressive chemicals. The design of the pump has a helical rotor revolving eccentrically with a resilient double helix stator of twice the pitch. The rotor turning within the stator forms cavities which progress uniformly from suction to discharge, carrying the material with them. MS range has a maximum suction lift of 8 metres, MM has 7.5 metres and the ML has 5.5 metres. Maximum liquid temperature rating of 70°C. Common spare parts are also listed at the bottom of the page.



CMS



CML



CMM

Dimensions

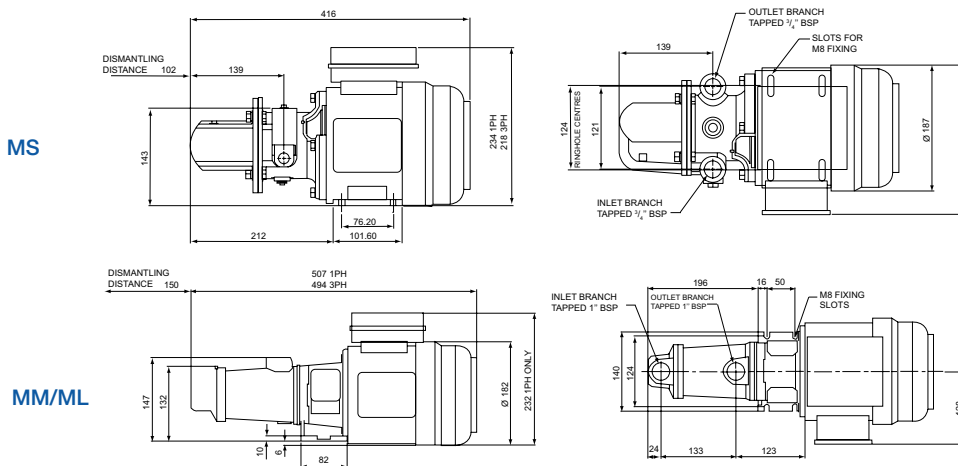

* All dimensions in mm's, (unless otherwise stated) and for guidance only. Please contact Mono for full certified drawings.

MODEL	VOLTAGE	INLET / OUTLET	LM	Kw	H x W x L mm	Kg	CODE
CMS 241	230v	3/4"	12.5	0.18	213 x 216 x 424	16	014-122
CMS 261	110v	3/4"	12.5	0.18	230 x 172 x 494	16	014-124
CMS 271	400v	3/4"	12.5	0.18	175 x 172 x 481	16	014-126
CMM 253	230v	1"	26.5	0.37	230 x 172 x 494	17	014-128
CMM 243	110v	1"	26.5	0.37	230 x 172 x 494	17	014-130
CMM 263	400v	1"	26.5	0.37	175 x 172 x 481	17	014-132
CML 253	230v	1"	52	0.75	230 x 172 x 494	27	014-134
CML 263	400v	1"	52	0.55	175 x 172 x 481	27	014-138

MODEL	STATOR CODE	ROTOR CODE	COUPLING CODE	MECH SEAL CODE
CMS	19569	19571	N/A	M806525G
CMM	19570	19572	19573	M805160G
CML	19570	19572	19573	M805160G

SURFACE MOUNTED PUMPS

ROTO PROGRESSIVE CAVITY PUMPS

B

Roto 's Compact MC Pump range has been developed for small capacity and low pressure transfer of light industrial and agricultural duties. These pumps are widely used wherever general pumping and transfer duties call for a compact and reliable pump of rugged and simple construction. Excellent suction lifts capability, Minimal pulsation avoids damage to shear sensitive products, Can handle liquids with fine solids, Simple in design and easy to dismantle and Low maintenance costs. MCCA maximum suction lift 8 metres.

Features

Excellent Suction Lift
Simple Design
Various Duties

Applications

Drainage Septic Tanks
Garden Sprinklers
Diesel Transfer



MCCA



MCCM/MCCL

MODEL	VOLTAGE	INLET / OUTLET	LM	Kw	AMPS	Kg	CODE
MCCA	110v	3/4" x 3/4"	12.5	0.18	3.25	16	014-365
MCCM	230v	1" x 1"	26.5	0.37	2.3	17	014-375
MCCM	110v	1" x 1"	26.5	0.37	5.93	17	014-380
MCCM	400v	1" x 1"	26.5	0.37	1.08	17	014-385
MCCL	230v	1" x 1"	52	0.75	4.07	25	014-390
MCCL	400v	1" x 1"	52	0.75	1.2	25	014-400

MODEL	STATOR CODE	ROTOR CODE	COUPLING CODE	MECH SEAL CODE
MCCA	014-420	014-426	–	014-432
MCCM	014-422	014-428	014-430	014-434
MCCL	014-422	014-428	014-430	014-434

SURFACE MOUNTED PUMPS

ROTO PROGRESSIVE CAVITY PUMPS

B

Roto's Little Champ pump range has been developed for general purpose pumping applications that demand high performance and durability. These multi taskers can be used for dosing, transfer and injection duties for a wide variety of fluids. These pumps are available in 4 sizes with flow rates, ranging from 780 L/Hour - 7980 L/Hour and pressures up to 2.8 bar. Excellent suction lift capabilities. Can handle liquid with varying viscosity and fine solids. Can be used for the transfer and dosing of chemicals and alkalies, transfer duties in food processing, winery, vegetable oils and diesel. DC11 & DC31 have acetal co-polymer pump housings. DC41 & DC51 have cast iron.

Features

Excellent Suction Lift
Simple Design
Various Duties

Applications

Drainage Of Septic Tanks
Garden Sprinklers
Diesel Transfer

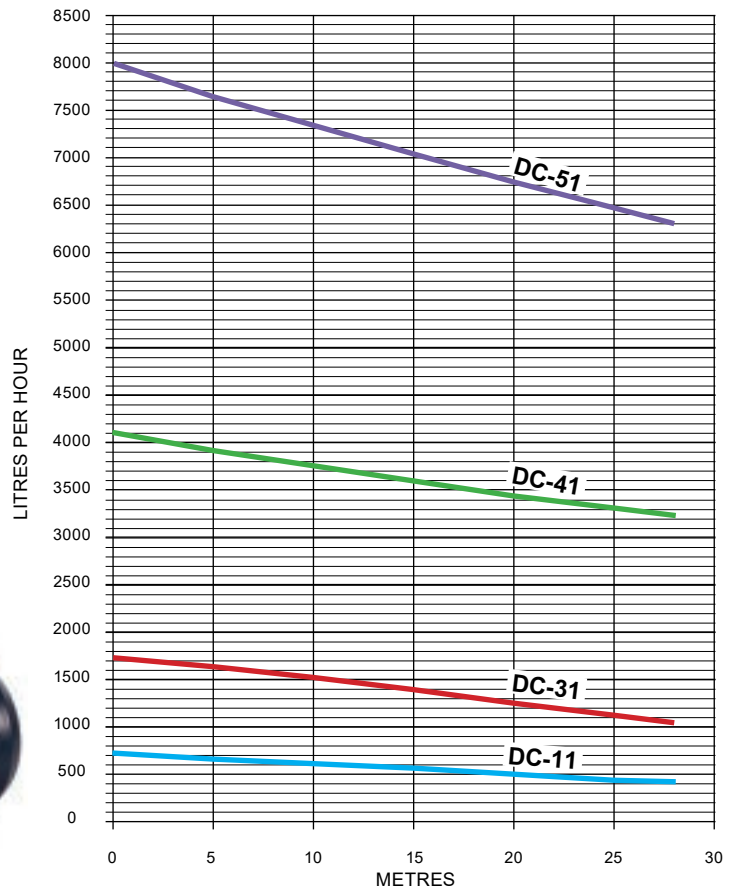

MODEL	VOLTAGE	INLET/OUTLET	L/H	BAR	Kw	AMPS	KG	CODE
DC-11	230v	1" x 1"	700	2.8	0.37	3.52	10.3	014-410
DC-11	400v	1" x 1"	700	2.8	0.37	1.47	10.3	014.414
DC-11	110v	1" x 1"	700	2.8	0.37	8.42	10.3	014-412
DC-31	230v	1" x 1"	1700	2.8	0.37	3.52	10.7	014-500
DC-31	400v	1" x 1"	1700	2.8	0.37	1.17	10.7	014-502
DC-31	110v	1" x 1"	1700	2.8	0.37	8.42	10.7	014-504
DC-41	230v	1½" x 1½"	4100	2.8	0.75	4.56	31.0	014-506
DC-41	400v	1½" x 1½"	4100	2.8	0.75	1.92	31.0	014-508
DC-41	110v	1½" x 1½"	4100	2.8	0.75	10.98	31.0	014-510
DC-51	230v	1½" x 1½"	7980	2.8	1.1	6.62	31.5	014-512
DC-51	400v	1½" x 1½"	7980	2.8	1.1	2.6	31.5	014-514
DC-51	110v	1½" x 1½"	7980	2.8	1.1	14.73	31.5	014-516

ACCESSORIES

WATER FILTERS

E

As water passes through the cartridge filters the suspended particles are removed while cartridges like containing polyphosphates or carbon are able to treat the water to eliminate the formation of scale or unpleasant odours. The transparent container allows the user to check the level of clogging of the filter and then, if necessary to replace the cartridge. 1" Inlet 1" Outlet. Max 105 L/M, Min 60 L/M, Min +5°C Max +50°C Max 8 Bar.



FT-HOLDER



FT-POLY

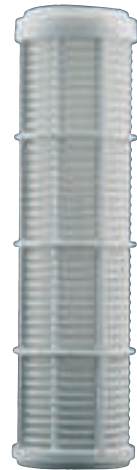

NY-NYLON



CA-CARBON



PL-PHOSPHATE

MODEL	SIZE	MATERIAL	MICRON	WASHABLE	APPLICATION	CODE
FT5	5"	PLASTIC	–	–	HOLDER 5"	015-012
CA	5"	CARBON	60	NO	ODOUR & CHEMICALS	015-027
FA	5"	POLYPROPYLENE	5	NO	GENERAL DIRT	015-037
NY	5"	NYLON	60	YES	FINE PARTICLES	015-042
FT10	10"	PLASTIC	–	–	HOLDER 10"	015-010
CA	10"	CARBON	60	NO	ODOUR & CHEMICALS	015-025
FA	10"	POLYPROPYLENE	5	NO	GENERAL DIRT	015-035
NY	10"	NYLON	60	YES	FINE PARTICLES	015-040
PL	10"	PHOSPHATE	–	NO	DEMINEALISES	015-015

LOW VOLTAGE PUMPS

SUBMERSIBLE LOW VOLTAGE PUMPS

C

Caravan pumps 04301 and the inline series are a compact design with a variety of uses including emptying and filling & transfer of clean and nuisance water. The 02, 03, 06 series of Bilge pumps are suitable for clean and dirty water and come with approx 1 metre of cable. The Ponds comes complete with 5 metres of cable. All the low voltage pumps have a duty cycle of approximately twenty minutes in every hour. Panel switch see page 248.

Features

Low Voltage

Applications

Marine
Bilge



TMC CARAVAN PUMP



03301



INLINE PUMP



03602



LOW LEVEL FLOAT SWITCH

MODEL	VOLTAGE	OUTLET	LM/HM	AMP	H x W x L mm	Kg	CODE
04301 CARAVAN PUMP	12v	11mm	7.5/7	2	104 x 40 x ---	0.15	020-930
0430107 INLINE PUMP	12v	13mm	17.5/7	3	135 x 43 x ---	0.17	020-924
02301	12v	¾"	30/3.8	3	107 x 80 x 108	0.5	020-955
03302	12v	¾"	45/3	4	123 x 88 x 120	0.6	020-960
03602	12v	1"	106/2.7	7	165 x 120 x 144	1.4	020-965
03603	12v	1"	132/4.1	10	165 x 120 x 144	1.5	020-970
06601	12v	1¼"	174/3.6	13	195 x 132 x 166	2.4	020-975
04301 CARAVAN PUMP	24v	11mm	7.5/7	1	104 x 40 x ---	0.15	020-932
0430107 INLINE PUMP	24v	13mm	17.5/7	1.5	135 x 43 x ---	0.17	020-926
02301	24v	¾"	30/3.8	2	107 x 80 x 108	0.5	020-957
03302	24v	¾"	45/3	2	123 x 88 x 120	0.6	020-962
03602	24v	1"	106/2.7	3	165 x 120 x 144	1.4	020-968
03603	24v	1"	132/4.1	5	165 x 120 x 144	1.5	020-972
06601	24v	1¼"	174/3.6	6	195 x 132 x 166	2.4	020-977
06121 LOW LEVEL FLOAT	-	-	-	MAX 10 AMP	70 x 70 x 118	0.2	020-948

LOW VOLTAGE PUMPS

SURFACE LOW VOLTAGE PUMPS

C

TMC 06203 series are flexible impeller pumps designed to transfer clean and dirty water with the advantage of being self priming from 0.5 metres vertically from dry. TMC 06205 series also flexible impeller pumps but with a macerator before the impeller. Used to transfer clean and dirty water containing domestic sewage and soft toilet paper. Can prime 0.5 metres vertically from dry. Not designed for macerating sanitary towels, nappies, towels etc. Do not run dry.

Features

Low Voltage

Applications

Marine

Bilge



**TMC FLEXIBLE
IMPELLER PUMP**



TMC MACERATOR PUMP



REPLACEMENT IMPELLER

MODEL	VOLTAGE	INLET / OUTLET	LM/HM	AMP	H x W x L mm	Kg	CODE
TMC-06203	12v	1" x 1" HOSE	30/4	8	97 x 128 x 172	2.7	020-938
TMC-06203	24v	1" x 1" HOSE	30/4	4	97 x 128 x 172	2.7	020-940
TMC-06205	12v	1½" x 1" HOSE	44/5	12	97 x 120 x 283	2.8	020-942
TMC-06205	24v	1½" x 1" HOSE	41/5	6	97 x 120 x 283	2.8	020-944
TMC-06211	REPLACEMENT IMPELLER FOR ABOVE MODELS						020-950

LOW VOLTAGE

SURFACE LOW VOLTAGE DIAPHRAGM PUMP

C

TMC-36501 4 chamber diaphragm design with a smooth constant flow. Can serve up to 3 to 4 outlets. Built in check valve to prevent back flow. Snap in inlet and outlet fittings ½” bsp and 13mm hose tails included. Built in thermal overload protection. Self priming and can be run dry. 1.4 bar cut in pressure and 2.8 bar cut off pressure. These are fixed and cannot be altered.



MODEL	VOLTAGE	INLET / OUTLET	LM/HM	AMP	H x W x L mm	Kg	CODE
TMC-36501	12v	½” or 13mm	16/28	15	97 x 90 x 235	4.6	020-910
TMC-36501	24v	½” or 13mm	16/28	8	97 x 90 x 235	4.6	020-915

SURFACE LOW VOLTAGE GEAR PUMP

C

Self priming bronze gear pump. Suitable for pumping diesel and light weight oils. Complete with inline fuse. Can prime (wet) from 2.5m. Recommended maximum oil thickness SAE 20W/50. Inline filter on the inlet with spare gauze.



MODEL	VOLTAGE	INLET / OUTLET	LM	AMP	H x W x L mm	Kg	CODE	PRICE
TMC-6010101	12v	15mm	4	15	171 x 183 x 161	4.6	3.8	020-900
TMC-6010101	24v	16mm	4	8	171 x 183 x 161	4.6	4.4	020-905

PRESSURE BOOSTING SYSTEMS

PRESS FLOW SWITCHES

E

EPR & DPR are a compact device for automatic control and protection of electric pumps up to 2,2 kW (3 HP). Multi-voltage (110 or 230v) and equipped with an innovative outlet pressure reducing/regulating system. In addition to the typical characteristics of traditional electronic pump controllers, integrated non-return valve, accumulation diaphragm, pressure gauge, dry-running protection and automatic reset, the EPR and DPR allow the user to adjust and stabilize the outlet pressure, avoiding overloads and water hammer. DPR version includes a digital display that can show an indication of current consumption and outlet pressure

Features

Adjustable Pressure
Multi Voltage
Outlet Pressure Indicator

Applications

Booster Sets
Low Pressure Mains



MODEL	VOLTAGE	INLET / OUTLET	MAX Kw	MAX AMPS	Kg	CODE
EPR	110v & 230v	1" x 1"	2.2	16A	2	9000-0180
DPR	110v & 230v	1" x 1"	2.2	16A	2	9000-0190

PRESSURE BOOSTING SYSTEMS

PRESS FLOW SWITCHES

E

Presscontrol and Controlpress are electronic pressure switch and protection devices. They can be fitted to almost any pump with an outlet pressure of two bar minimum to ten bar maximum with a flow rate of between 40-200 litres per min. The Presscontrol and Controlpress will turn off in the case of no water to protect the pump from dry running. Suitable for most water systems from well, tank or low pressure mains. Two versions allow small and larger motors to be installed. Controlpress is also pressure adjustable. Fuel oil Presscontrol has the same characteristics as above and is suitable for controlling pumps that are used for diesel fuel oil.



PRESSCONTROL UP

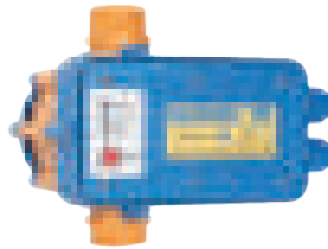

MASCONTROL

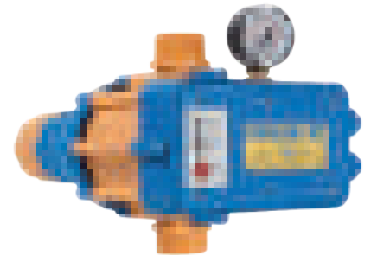

CONTROLPRESS



FUEL OIL PRESSCONTROL

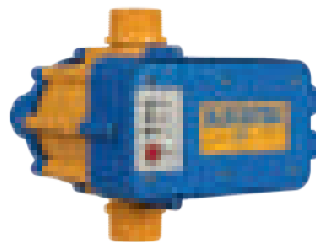

MASCONTROL 12V

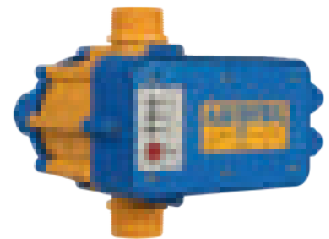

MASCONTROL 24V

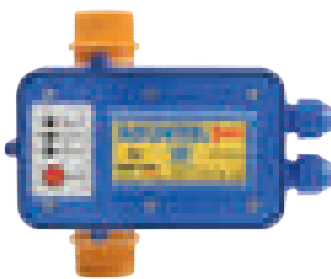

MASCONTROL 3



MODEL	VOLTAGE	INLET / OUTLET	MAX Kw	MAX AMPS	Kg	CODE
PRESSCONTROL UP	110v & 230v	1" x 1"	0.75/1.5	10	1.4	060-430
MASCONTROL	110v & 230v	1¼" x 1¼"	1.1/2.2	16	2.6	060-435
CONTROLPRESS	110v & 230v	1¼" x 1¼"	1.1/2.2	16	2.6	060-438
FUEL OIL PRESSCONTROL	110v & 230v	1" x 1"	0.75/1.5	10	1.4	050-304
MASCONTROL	12v	1" x 1"	0.18	20	1.4	060-432
MASCONTROL	24v	1" x 1"	0.37	22	1.4	060-434
MASCONTROL 3	400v	1¼" x 1¼"	2.2	6	2.6	060-422

SURFACE MOUNTED PUMPS

TRADITIONAL VERTICAL SUMP PUMPS

E

NG and NGM vertical motor driven stem pumps for pumping liquid that is not particularly dense such as cellar and waste water with no abrasives. GF and GFM vertical, motor driven stem pumps for pumping dirty water with no abrasives. Motor support, pump body, volute and impeller are made from cast iron. Stainless steel shaft, with brass shaft guide bushes. Maximum liquid temperature 90°C. 15mm maximum solids handling. During operation the pump must be submerged up to the first hole on the stem to allow the shaft guide bush to be lubricated by the pumped liquid.

Features

Dry Motor

Applications

Waste Water

Dirty Water

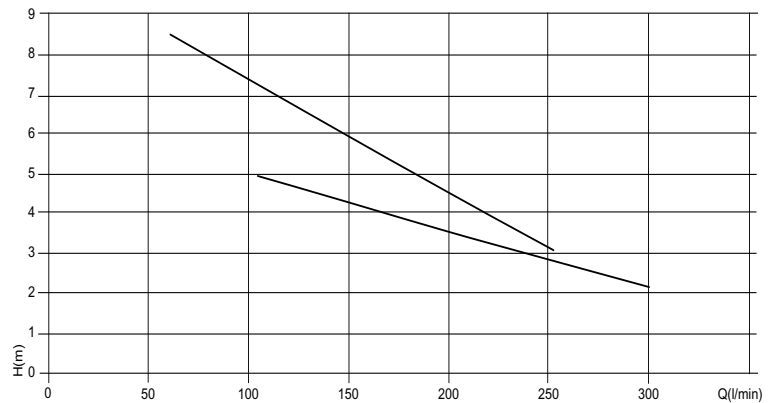

MODEL	VOLTAGE	OUTLET	LM/HM	Kw	AMPS	A x B x C mm	Kg	CODE
NGM-80	230v	1¼"	240/8	0.55	3.5	165 x 800 x 130	10.2	075-050
NGM-100	230v	1¼"	240/8	0.55	3.5	165 x 1000 x 130	11.4	075-052
NGM-120	230v	1¼"	240/8	0.55	3.5	165 x 1200 x 130	12.2	075-054
NG-80	400v	1¼"	240/8	0.55	1.42	165 x 800 x 130	10.2	075-056
NG-100	400v	1¼"	240/8	0.55	1.42	165 x 1000 x 130	11.4	075-058
NG-120	400v	1¼"	240/8	0.55	1.42	165 x 1200 x 130	12.2	075-060
GFM-100	230v	2"	500/5	1.1	6.3	165 x 1000 x 160	21	011-780
GFM-150	230v	2"	500/5	1.1	6.3	165 x 1500 x 160	23	011-782
GF-100	400v	2"	500/5	1.1	2.5	165 x 1000 x 160	21	011-788
GF-150	400v	2"	500/5	1.1	2.5	165 x 1500 x 160	23	011-790

SURFACE MOUNTED PUMPS

MACHINE TOOL COOLANT (SUDS) PUMPS

E

Machine tool suds pumps designed for the pumping of cooling liquids, cutting compounds and cutting oil. Flanged designed for vertical assembly directly on top of the coolant vessels. Minimum and maximum temperatures are 0-60°C. Not for pumping abrasives, so the liquid being pumped has to be filtered to stop impurities entering the pump chamber. Plastic impeller.

Features

Coolant Pump for Machine Tools

Applications

Cooling Lubricants

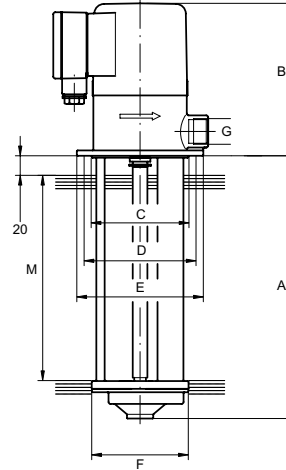

TYPE	A mm	B mm	C mm	D mm	E mm	F mm	M mm
4COA-2-12	120	156	100	115	130	99.5	80
4COA-2-17	170	156	100	115	130	99.5	130
4COA-2-22	220	156	100	115	130	99.5	180
4COA-2-27	270	156	100	115	130	99.5	230
4COA-4-12	120	156	100	115	130	99.5	80
4COA-4-17	170	156	100	115	130	99.5	130
4COA-4-22	220	156	100	115	130	99.5	180
4COA-4-27	270	156	100	115	130	99.5	230
4COA-6-12	120	171	140	160	180	99.5	80
4COA-6-17	170	171	140	160	180	99.5	130
4COA-6-22	220	171	140	160	180	99.5	180
4COA-6-27	270	238	140	160	180	99.5	230
4COA-10-27	270	238	140	160	180	130	210
4COA-10-35	350	238	140	160	180	130	290

MODEL	VOLTAGE	OUTLET	LM/HM	WATT	AMPS	Kg	CODE
4COA-2-12 (NT-120)	400v	3/4"	25/4	90	0.35	3.5	075-010
4COA-2-17 (NT-170)	400v	3/4"	25/4	90	0.35	3.8	075-012
4COA-2-22 (NT-220)	400v	3/4"	25/4	90	0.35	4.1	075-014
4COA-2-27 (NT-270)	400v	3/4"	25/4	90	0.35	4.4	075-016
4COA-4-12 (NU-120)	400v	3/4"	40/4	120	0.45	3.7	075-020
4COA-4-17 (NU-170)	400v	3/4"	40/4	120	0.45	4.0	075-022
4COA-4-22 (NU-220)	400v	3/4"	40/4	120	0.45	4.4	075-024
4COA-4-27 (NU-270)	400v	3/4"	40/4	120	0.45	4.7	075-026
4COA-6-12 (NV-120)	400v	3/4"	63/4	155	0.6	4.3	075-028
4COA-6-17 (NV-170)	400v	3/4"	63/4	155	0.6	4.6	075-030
4COA-6-22 (NV-220)	400v	3/4"	63/4	155	0.6	5.0	075-032
4COA-6-27 (NV-270)	400v	3/4"	63/4	155	0.6	5.3	075-034
4COA-10-27 (NZ-270)	400v	1 1/4"	100/4	360	1.1	7.6	075-036
4COA-10-35 (NZ-350)	400v	1 1/4"	100/4	360	1.1	8.4	075-038
400v To 230v Single Phase Conversion (NETT)							075-040

GENERATORS

GUIDE FOR CHOOSING THE CORRECT GENERATOR FOR YOUR NEEDS

1. Determine the power (Kw) required to run all of your equipment at any one time. All electrical products will have a data label with the power usage.

See notes below if there are appliances with electric motors or sensitive power equipment eg computers.

2. Calculate the total amount of power required.

3. Choose a generator that either meets this total – or exceeds it, to allow for extra scope.

Notes

ELECTRIC MOTORS

Items with electrical motors for example washing machines, water pumps, fridges, freezers require a greater starting up wattage.

A normal guideline rule for example is a water pump of 750 watts with a capacitor start circuit will require three times of power on start up. So 750 watts x 3 times = 2250 watts, a generator of minimum 2.3 kw power is then required.

Most hand held power tools using universal commutator motors do not require additional starting up power.

SENSITIVE EQUIPMENT

It is not advisable to run for example, computers from a standard generator. A generator that has AVR – Automatic Voltage Regulation, like the Villiers series on page 270, have a more stable electricity output, but, it is still advisable to use an anti surge device as recommended by computer manufacturers.

If you have any other questions, or need help and advice, please call our sales team who will be glad to help.

POWER GUIDE

APPLIANCE	WATTS	APPLIANCE	WATTS
LIGHT BULB	100	LAWNMOWER	1000
PALM SANDER	175	5" CIRCULAR SAW	1000
STRIMMER 10"	350	ROUTER	1000
RADIO/HIFI	200	BELT SANDER	1020
COLOUR TV	250	VACUUM CLEANER	1100
FLOOD LAMP	500	COFFEE MAKER	1200
13MM DRILL	450	CEMENT MIXER	1320
WATER PUMP 750W	2250	CHAIN SAW 10-16"	1500
JIG SAW	400	600W MICROWAVE	1500
BENCH GRINDER	400	ARC WELDER 130A	3500
COMPUTER	400	HOT AIR GUN	1500
ORBITAL SANDER	450	HAIRDRYER	1000
HEDGE TRIMMER	500	COMPRESSOR	2200
PLANER	700	12" GRINDER	250
4" ANGLE GRINDER	550	HAMMER DRILL	2500
1/3 HP SPRAYER	600	KETTLE	2500
5" ANGLE GRINDER	750	FAN HEATER	3000
FRIDGE	700	HAMMER/BREAKER	3000

GENERATORS

VILLIERS INVERTER GENERATORS

A



G1000i/2000i



G3000i



G3000i SHOWN WITH HANDLE

MODEL	G1000i	G2000i	G3000i
RATED VOLTAGE	230v		
OUTLETS	1 x 13A DOMESTIC	2 X 13A DOMESTIC	
DC OUTPUT	12v / 8.3A		
USB OUTPUT	5v / 1A		
RATED OUTPUT	1.0 KW	1.6 KW	2.8 KW
MAX OUTPUT	1.1 KW	1.8 KW	3.1 KW
ENGINE	AIR COOLED, 4 STROKE, OHV, SINGLE CYLINDER		
OIL ALERT	YES	YES	YES
FUEL CAPACITY	3 LITRES	4 LITRES	9 LITRES
FULL LOAD RUNNING TIME	4 HOURS	4 HOURS	5 HOURS
HALF LOAD RUNNING TIME	6 HOURS	6 HOURS	9 HOURS
NOISE LEVEL @ 7M	58db	65db	68db
DIMENSIONS (H x W x Lmm)	380 x 240 x 450	459 x 290 x 498	493 x 432 x 605
FUEL TYPE	UNLEADED PETROL		
WEIGHT (KG)	13	22	37
STARTING SYSTEM	RECOIL ONLY		
CODE	G1000i	G2000i	G3000i

Need help in choosing which size generator is best suited for your needs? See page 268 for a guide.

GENERATORS

VILLIERS V SERIES PETROL ENGINE GENERATORS C/W AVR – AUTOMATIC VOLTAGE REGULATOR

A

The Villiers petrol engine driven generators which are generally quieter (69db@7m) than standard open framed versions. Carry frame mounted with automatic voltage regulation with both recoil and electric start. The unit is powered by a Villiers oil alert engine with extra large air cleaner and exhaust silencer. The R3000 is supplied with 1 x 13A 230v domestic socket and 1 x 110v industrial socket. The V6000 is supplied with 1 x 32A 230v, 1 x 32A 110v and 1 x 16A industrial sockets outlets. 12 volt DC outlet. Mains power is protected by a circuit breaker and also fitted with a volt meter. All models come complete with a wheel kit and if required needs to be assembled.



R3000



V6000

MODEL NO.	R3000	V6000
RATED VOLTAGE (V)		
OUTLETS	1 X 230V 13A DOMESTIC 1 X 110V 16A INDUSTRIAL	1 X 230V 32A INDUSTRIAL 1 X 110V 32A INDUSTRIAL 1 X 110V 16A INDUSTRIAL
RATED OUTPUT (Kw)	2.2Kw	5.5Kw
MAX OUTPUT (Kw)	2.5Kw	6.0Kw
DC OUTPUT	12 VOLT 8.3 AMPS	12 VOLT 12.3 AMPS
ENGINE	4-STROKE OHC SINGLE CYLINDER	4-STROKE OHC SINGLE CYLINDER
HORSE POWER (HP)	6.5	13
OIL ALERT	YES	YES
FUEL CAPACITY (L)	15L	25L
CONTINUOUS RUN TIME (H@50% LOAD)	12 HOURS	11 HOURS
NOISE LEVEL DB @ 7m	69DB	69DB
DIMENSIONS (H x W x L mm)	465 x 475 x 594	559 x 562 x 684
NET WEIGHT (Kg)	55Kg	96Kg
STARTING SYSTEM	RECOIL ONLY	RECOIL & ELECTRIC START (BATTERY INC)
RECOMMENDED LUBE OIL	SAE 10W30, 15W40	SAE 10W30, 15W40
FUEL TYPE	UNLEADED PETROL	UNLEADED PETROL
WHEEL KIT	YES, SUPPLIED NOT FITTED	YES, SUPPLIED NOT FITTED
CODE	R3000	V6000

Need help in choosing which size generator is best suited for your needs? See page 268 for a guide.

GENERATORS

VILLIERS EN SERIES PETROL ENGINE GENERATORS

A

High performance industrial generators with a high quality Villiers petrol engine, complete with low oil level shutdown and high quality European alternator. Dual voltage sockets and overload protection. Heavy duty powder coated frames complete with anti-vibration mounts.



WHEEL KIT
090-886



MODEL NO.	EN2800V	EN3500V
RATED VOLTAGE (V)	110/230v	
OUTLETS	1 X 110V 16A IND 1 X 230V 16A IND	1 X 110V 16A IND 1 X 230V 16A IND
RATED OUTPUT (Kw)	2.8Kw	3.5Kw
MAXIMUM OUTPUT (Kw)	2.8Kw	3.5Kw
DC OUTPUT	NO	
ENGINE	G210VG	G210VG
HORSE POWER	6.5	6.5
OIL ALERT	YES	
FUEL CAPACITY (L)	3	3
CONTINUOUS RUN TIME (H @ 50% LOAD)	2.8	2.8
NOISE LEVEL (DBA) ≤ 7 METRES	96	96
DIMENSIONS (H x W x L mm)	460 X 480 X 640	460 X 480 X 640
NET WEIGHT (Kg)	42	44
STARTING SYSTEM	RECOIL START ONLY	
RECOMMENDED LUBE OIL TYPE	SAE 10W30, 15W40	
FUEL TYPE	UNLEADED PETROL	
WHEEL KIT	OPTIONAL EXTRA – CODE 090-886	
CODE	EN2500V	EN3500V

Need help in choosing which size generator is best suited for your needs? See page 268 for a guide.

GENERAL PURPOSE REPLACEMENT ENGINES

VILLIERS PETROL

A



R80V



G180VFQ



PARALLEL KEY WAY Q SHAFT



GENERATOR SHAFT

MODEL NO.	R80V	G180V	G210V
ENGINE TYPE	SINGLE CYLINDER 4-STROKE HV FORCED AIR COOLING		
H/P	2.0	6.5	7.0
MAX TORQUE (N • M/RPM)	4.0 / 2500	10.5 / 3000	12 / 2500
BORE X STROKE	52 X 37	68 X 45	70 X 55
DISPLACEMENT	78.5	163	212
COMPRESSION RATIO	9.0:1	8.5:1	8.5:1
OIL CAPACITY (L)	0.35	0.6	0.5
NOISE LEVEL (DBA) ≤ 7 METRES	80	70	70
LUBRICATION SYSTEM	SPLASH	SPLASH	SPLASH
OIL ALERT	YES	YES	YES
PTO° SHAFT ROTATION	ANTI CLOCKWISE (FROM PTO SIDE) ALL MODELS		
IGNITION SYSTEM	TRANSISTORISED MAGNETO ALL MODELS		
AIR CLEANER	SEMI DRY, OIL BATH, DUAL ELEMENT TYPE ALL MODELS		
FUEL CONSUMPTION (G/Kw Hour)	≤ 420	≤ 395	≤ 420
IDLE SPEED (R/Min)	1400 ± 150 ALL MODELS		
SPEED FLUCTUATING RATIO	≤ 10% ALL MODELS		
DIMENSION	300 X 304 X 310	312 X 362 X 335	312 X 376 X 335
DRY WEIGHT Kg (PACKING)	10 (11)	15 (18)	16 (19)

MODEL / VERSION	CODE	CODE	CODE
Q SHAFT RECOIL START	R80VFQ	G180VFQ	G210VFQ
Q SHAFT ELECTRIC START			G210VFQES
GENERATOR TAPER SHAFT RECOIL START		G180VFG	G210VFG

For dimensions see page 274.

GENERAL PURPOSE REPLACEMENT ENGINES

VILLIERS PETROL

A

G210VFQES

G300FQ

G670V

MODEL NO.	G300V	G390V	G420V	G670V
ENGINE TWIN CYLINDER	G300V/G390V/G420V: SINGLE CYLINDER 4-STROKE HV FORCED AIR COOLING. G670: AIR COOLED 4-STROKE OHV			
H/P	9	13	15	20
MAX TORQUE (N • M/RPM)	19.0 / 3000	26.5 / 3000	9.8 / 4000	45 / 2500
BORE X STROKE	80 X 60	88 X 64	90 X 66	78 X 70
DISPLACEMENT	301	389	420	6701
COMPRESSION RATIO	8.5:1	8.1:1	8.3:1	8.5:1
OIL CAPACITY (L)	1.1	1.1	1.1	1.5
NOISE LEVEL (DBA) ≤ 7 METRES	80	80	80	75
LUBRICATION SYSTEM	SPLASH	SPLASH	SPLASH	SPLASH
OIL ALERT	YES	YES	YES	YES
PTO° SHAFT ROTATION	ANTI CLOCKWISE (FROM PTO SIDE) ALL MODELS			
IGNITION SYSTEM	TRANSISTORISED MAGNETO ALL MODELS			
AIR CLEANER	SEMI DRY, OIL BATH, DUAL ELEMENT TYPE ALL MODELS			
FUEL CONSUMPTION (G/KW Hour)	≤ 374	≤ 395	≤ 395	(NO FUEL TANK)
IDLE SPEED (R/Min)	1400 ± 150 ALL MODELS			1600-2000
SPEED FLUCTUATING RATIO	≤ 10% ALL MODELS			
DIMENSION	380 X 430 X 410	405 X 450 X 443	405 X 452 X 443	460 X 300 X 500
DRY WEIGHT KG (PACKING)	26 (29)	31 (34)	32 (35)	45 (48)
MODEL / VERSION	CODE	CODE	CODE	CODE
PARALLEL SHAFT RECOIL START	G300VFQ	G390VFQ		
PARALLEL SHAFT ELECTRIC START	G300VFQES	G390VFQES		G420VFQES
GENERATOR TAPER SHAFT RECOIL START	G300FG	G390VFG		
GENERATOR TAPER SHAFT ELECTRIC START		G390VFGES		G420VFGES

For dimensions see page 274.

GENERAL PURPOSE REPLACEMENT ENGINES

ENGINE DIMENSIONS

A

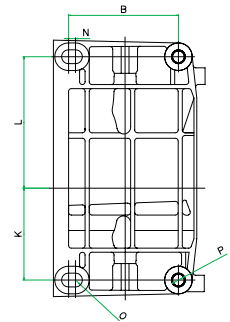
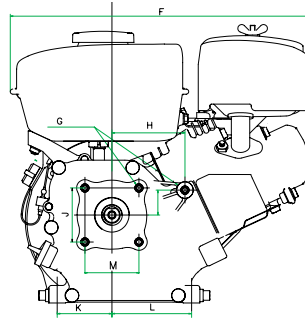
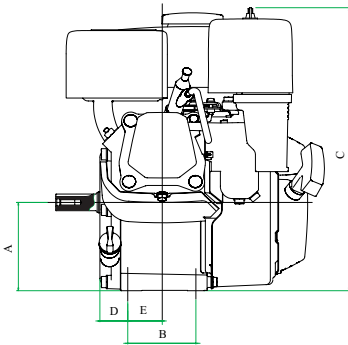

MODEL NO.	A	B	C	D	E	F	G	H	I	J	K	L	M	N	O	P
R80V	90.7	62	300	-	-	309	M8 x 13 mm deep	-	-	65.1	38	67	65.1	-	-	M8
G180	106	75.5	345	35.7	39.5	362	M8 x 15 mm deep	88	30	65.1	66	96	65.1	5	10 x 14	ø9
G210	106	75.5	345	35.7	39.5	362	M8 x 15 mm deep	88	30	65.1	66	96	65.1	5	10 x 14	ø9
G300	135.5	103	423	57.5	34.5	430	M8 x 18 mm deep	103	35	89.8	90	106	89.9	17	12 x 23	ø12
G390	135.5	103	443	73.0	27.0	456	M8 x 18 mm deep	103	35	89.8	90	106	89.9	17	12 x 23	ø12
G420	135.5	103	443	73.0	27.0	456	M8 x 18 mm deep	103	35	89.8	90	106	89.9	17	12 x 23	ø12

PARALLEL KEY WAY

MODEL NO.	SA	SB	SC	SD	SE	SF	SG	SH	SI
R80V	4.78	13.02	45	15.80 (5/8")	1/4-28 UNF	25	58.5	60.1	41.25
G180	4.78	16.36	45.5	19.05 (3/4")	5/16-24 UNF	17	58.5	61.7	41.25
G210	4.78	16.36	45.5	19.05 (3/4")	5/16-24 UNF	17	58.5	61.7	41.25
G300	6.30	21.82	56.0	25.40 (1")	7/16-20 UNF	28	72.2	88.5	N/A
G390	6.30	21.82	56.0	25.40 (1")	3/8-24 UNF	28	72.2	88.5	N/A
G420	6.30	21.82	56.0	25.40 (1")	3/8-24 UNF	28	72.2	88.5	N/A

GENERATOR SHAFT

MODEL NO.	GA	GB	GC	GD	GE	GF	GG	GH	GI
G180	M8 x 1	TAP 1:5	23	39.1	55.6	20	19.2	5.5	41.25
G210	M8 x 1	TAP 1:5	23	39.1	55.6	20	19.2	5.5	41.25
G300	M10 x 1.25	TAP 1:5	30	13.1	47.6	26	110		
G390	M10 x 1.25	TAP 1:5	30	19.0	48.0	26	110		
G420	M10 x 1.25	TAP 1:5	30	19.0	48.0	26	110		

KEY SHAFT FOR R80 – G420F

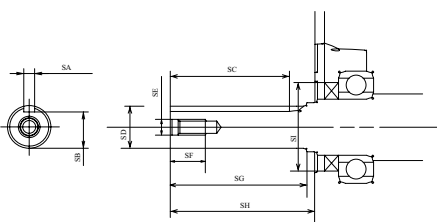

GENERATOR SHAFT FOR G180 – G210F

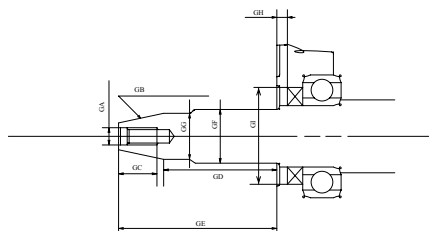

GENERATOR SHAFT FOR G300 – G420F

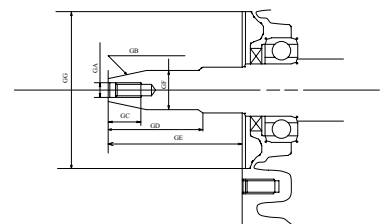

GENERAL PURPOSE REPLACEMENT ENGINES

PETROL ENGINES – REDUCTION & CLUTCH SERIES

A



G210VFS-C



G180VFS-B

MODEL	HP	SHAFT SIZE	CODE
G180VFS-C	5.5 Hp	20 mm	G160VFS-C RED CH
G210VFS-C	6.5 Hp	20 mm	G210VFS-C RED CH
G300VFS-C	9 Hp	25 mm	G300VFS-C RED CH
G390VFS-C	13 Hp	25 mm	G390VFS-C RED CH

MODEL	HP	SHAFT SIZE	CODE
G180VFS-B	5.5 Hp	20 mm	G160VFS-B CLU
G210VFS-B	6.5 Hp	20 mm	G210VFS-B CLU
G300VFS-B	9 Hp	22 mm	G300VFS-B CLU

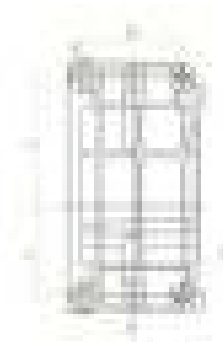
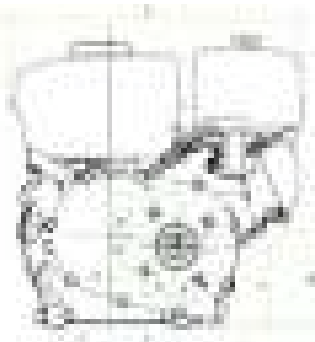
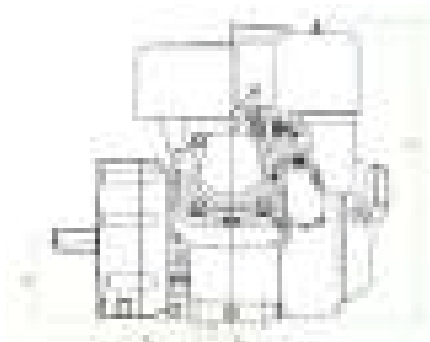

MODEL NO.	A	B	C	D	E	F	G	H	I	J	K	L	M	N	O	P
G180VFS-B	92	80	335	87.0	39.5	362	M8 x 15 mm deep	35	66	96	90.5	92	106	5	10 x 15	ø9
G210VFS-B	92	80	335	87.0	39.5	362	M8 x 15 mm deep	35	66	96	90.5	92	106	5	10 x 15	ø9
G300VFS-B	133.5	110	423	87.7	34.5	430	M8 x 16 mm deep	35	90	105.5	90.5	133.5	133.5	13	12 x 25	ø12

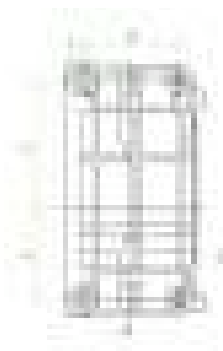
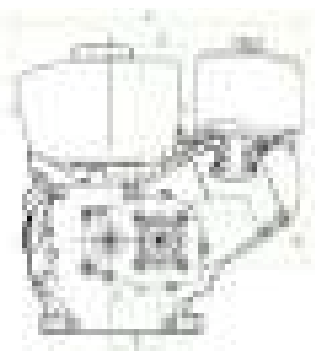
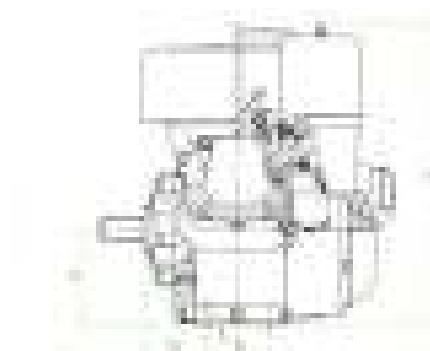

MODEL NO.	A	B	C	D	E	F	G	H	I	J	K	L	M	N
G180VFS-C	106	80	335	75.0	39.5	362	M8 x 15 mm deep	54	66	96	65.9	5	10 x 15	ø9
G210VFS-C	106	80	335	75.0	39.5	362	M8 x 15 mm deep	54	66	96	65.9	5	10 x 15	ø9
G300VFS-C	133.5	110	423	87.7	34.5	430	M8 x 15 mm deep	70	90	105.5	68.2	13	12 x 25	ø12
G390VFS-C	133.5	103	440	\	\	465	M8 x 15 mm deep	70	\	\	\	13	12 x 25	ø12

For a full dimensional drawing on the G390VFS-C please contact us.

SURFACE MOUNTED PUMPS

SWIMMEY – COMMON PARTS

E

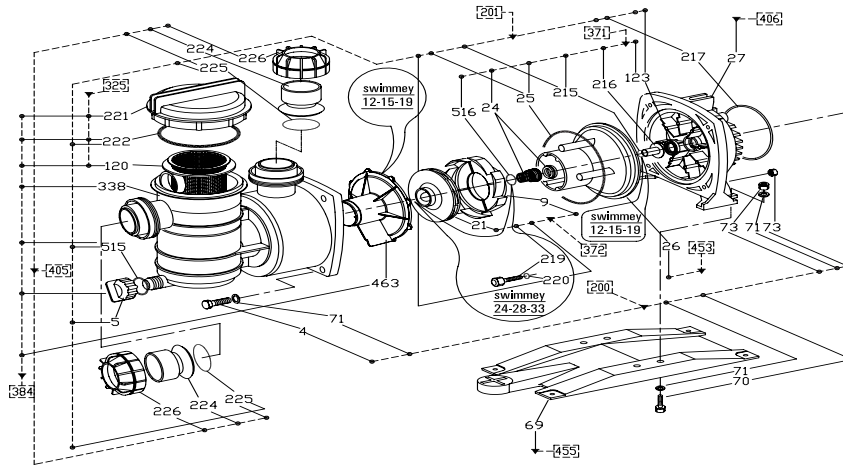

KIT REF	KIT DESC	PART REF	DESC	SW12	SW15	SW19	SW24	SW24	SW28	SW28	SW33	SW33
				M&T	M&T	M&T	M	T	M	T	M	T
201	Gasket Kit	123	Seal Ring	ZBR40640	ZBR40650	ZBR40660						
		503	V Guard									
		217	Gasket									
		215	O Ring Shaft									
		25	O Ring Pump Body									
		220	O Ring Imp Screw									
		515	O Ring Plug									
		225	O Ring Inlet/Outlet									
		222	O Ring Filter									
		5	Plug									
325	Filter Complete	221	Cover Filter	ZBR41050								
		222	O Ring Filter Cover									
		120	Filter									
371	Mech Seal Kit	123	Seal Ring	ZBR40670			ZBR40680					
		216	Shaft Sleeve									
		215	O Ring Shaft									
		25	O Ring Pump Body									
		24	Mechanical Seal									
372	Hydraulic Kit	9	Diffuser									
		220	O Ring Imp Screw	ZBR 40740	ZBR 40750	ZBR 40760	ZBR 40770	ZBR 40780	ZBR 40790	ZBR 40800	ZBR 40810	ZBR 40820
		219	Screw Imp Lock									
		21	Impeller									
384	Pump Body Kit	463	Adapter Flange	ZBR41020			ZBR41030					
		515	O Ring Plug									
		120	Filter									
		221	Cover Filter									
		222	O Ring Filter Cover									
		5	Plug									
		338	Pump Body									
405	Coupling Kit	226	Union Nut x2	ZBR41010 + 48.5 mm / 50 mm / 1½"								
		224	Coupling Joint x2									
		225	O Ring Inlet/Outlet x2									
406	Flange	27	Flange Bracket	ZBR40690	ZBR36000	ZBR40700	ZBR40710					
453	Flange B/P	26	Flange Backplate	ZBR40720			ZBR40730					
455	Base Kit	69	Base	ZBR41040								

SURFACE MOUNTED PUMPS

SWIMMING POOL PUMPS

E

The SWIMMEY series pumps are designed to achieve maximum reliability regarding filtering in the recirculation of water treated with chlorine. Single-phase power supply with capacitor permanently on and thermal protection built into the motor casing. Three-phase power supply with external protection provided by the user. Type of liquid: swimming pool water treated with chlorine. Maximum temperature of the liquid 40°C. Maximum operating pressure: 2.5 bar. Maximum recommended suction height: 3 m with foot valve.

Features

Circulation
Self Priming
High Volume

Applications

Swimming Pools
Salt Water

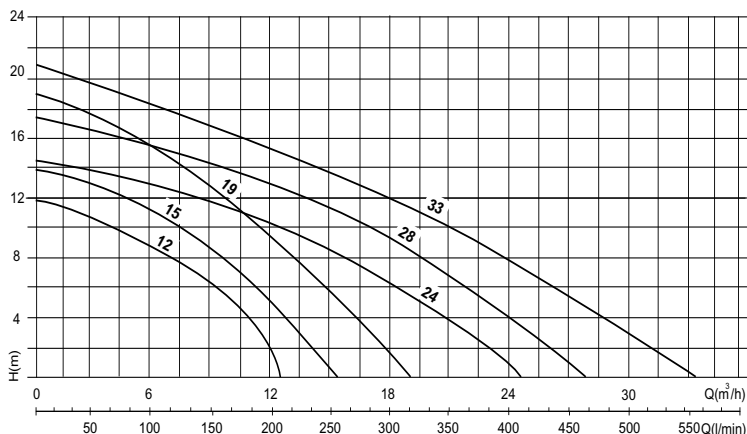

DIMENSIONS mm							
MODEL	A	B	C	D	E	F	DN
SW12	293	210	582	180	280	318	50
SW15	293	210	582	180	280	318	50
SW19	293	210	610	180	280	318	50
SW24	293	210	610	180	280	318	50
SW28	293	210	635	180	280	318	50
SW33	293	210	635	180	280	318	50

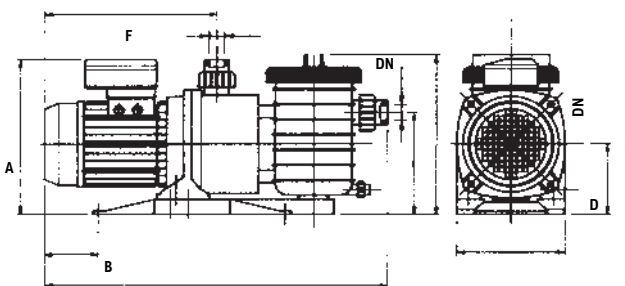

MODEL	VOLTAGE	LM/HM	Kw	HP	AMPS	Kg	CODE
SWIMMEY 12M	230v	210/12	0.37	0.5	2.5	8.0	014-010
SWIMMEY 15M	230v	250/15	0.5	0.75	3.0	8.5	014-012
SWIMMEY 19M	230v	310/19	0.75	1.0	5.0	10.2	014-014
SWIMMEY 24M	230v	400/14	1.0	1.3	4.8	11.0	014-016
SWIMMEY 28M	230v	470/17	1.13	1.5	7.0	13.0	014-038
SWIMMEY 33M	230v	550/20	1.5	2	8.5	14.5	014-040
SWIMMEY 12T	400v	210/12	0.37	0.5	1.0	8.0	014-011
SWIMMEY 15T	400v	250/15	0.5	0.75	1.3	8.5	014-013
SWIMMEY 19T	400v	310/19	0.75	1.0	1.9	10.2	014-015
SWIMMEY 24T	400v	400/14	1.0	1.3	2.2	11.0	014-017
SWIMMEY 28T	400v	470/17	1.13	1.5	2.4	13.0	014-039
SWIMMEY 33T	400v	550/20	1.5	2	3.6	14.5	014-041

GARDEN PUMPS

CAST IRON "VILLAGE" PUMPS

IDEAL GARDEN DECORATION – HAND WORKING – 7M SUCTION IF USED WITH FOOTVALVE

E

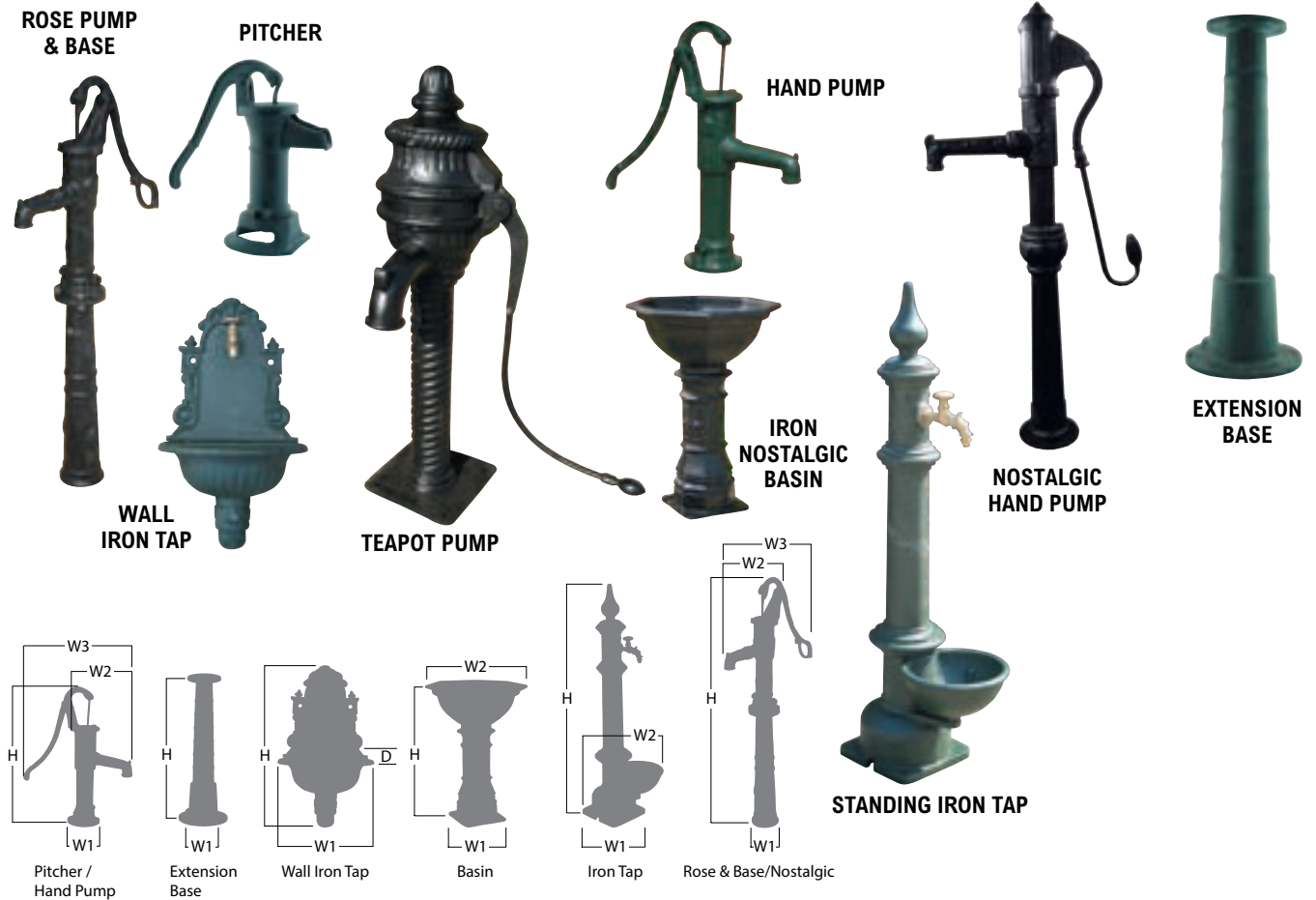

MODEL	Kg	Hmm	W1 mm	W2 mm	W3 mm	CODE
PITCHER PUMP (SINK TYPE)	6	390	165	190	340	050-230
HAND PUMP	16	640	160	330	650	050-232
EXTENSION BASE HAND PUMP	19	690	240	–	–	050-234
90° WALL FLANGE FOR HAND PUMP	2	–	–	–	–	050-236
ROSE PUMP	17	640	160	330	650	050-11404
ROSE BASE	19	690	240	–	–	050-11405
TEAPOT PUMP	82	1180	300	400	600	050-11408
STANDING IRON TAP	47	1220	260	400	–	050-15121
WALL IRON TAP	17	700	430	230 deep	–	050-15131E
IRON NOSTALGIC BASIN	32	645	210	430	–	050-15104
NOSTALGIC HAND PUMP	50	1540	150	600	750	050-11409

COMMON SPARE PARTS FOR CAST IRON VILLAGE PUMPS

E

PART	TO SUIT	CODE
LEATHER WASHER 75MM	PITCHER, HAND, ROSE & NOSTALGIC PUMP	050-245
LEATHER WASHER 90MM	TEEPOT PUMP	050-11018
PLUNGER C/W 75MM WASHER	PITCHER, HAND, ROSE & NOSTALGIC PUMP	050-11015
PLUNGER C/W 90MM WASHER	TEEPOT PUMP	050-11045



LEATHER WASHER



PLUNGER C/W LEATHER WASHER

GARDEN PUMPS

VERSAILLES

E

Versailles stainless steel water feature pumps. Supplied with 1¼"-1" plastic reducer to accept the fountain head optional accessories. 10 metre power cable. Maximum submersion depth 7 metres.

Features

Stainless Steel

Applications

Fountains



CAMPANA

GASIER

VULCANO

MODEL	VOLT	OUTLET	LM/HM	Kw	AMP	H x W x L mm	Kg	CODE
VERSAILLES 160/8	230v	1¼"	150/7.5	0.4	2.4	178 x 178 x 425	7	555-072
VERSAILLES 250/10	230v	1¼"	250/9.5	0.55	4.5	178 x 178 x 620	7.8	555-074
VERSAILLES 350/12	230v	1¼"	350/11	0.8	5.1	178 x 178 x 620	9.3	555-076
ACCESSORIES								
VULCANO FOUNTAIN HEAD								010-002
GAISER FOUNTAIN HEAD								010-004
CAMPANA FOUNTAIN HEAD								010-006

APPROX DIAMETER & HEIGHT OF WATER FEATURES IN CM

MODEL	VULCANO	GASIER	CAMPANA
VERSAILLES 160/8	Ø 180 - H 360	Ø 20 - H 110	Ø 90 - H 45
VERSAILLES 250/10	Ø 200 - H 420	Ø 30 - H 180	Ø 95 - H 45
VERSAILLES 350/12	Ø 200 - H 480	Ø 50 - H 230	Ø 100 - H 45

The Puddle Buddy 100 can work in manual mode or in an automatic level sensing mode to detect water levels and switch the pump on. When activated by the chosen sensor level the pump will continue to run when the water has dropped below the sensor for approximately 3 minutes, pumping more of the residue water away. 1½” Outlet with step adapter hose tail for 1½” and 1” Hose, built in non return valve. Complete with 10 metres of power cable. Drain Buddy 400 Auto for light duty clean and dirty water applications like emptying of flooded cellars, basements and rain water collection tanks. 1½” Outlet with step adapter hose tail for 1¼” and 1” Hose. Complete with 10 metres of power cable.

Features

- Puddle Buddy Residue
- Drain Buddy Drainage
- Automatic

Applications

- Drainage
- Sumps
- Cellers



PUDDLE BUDDY 100

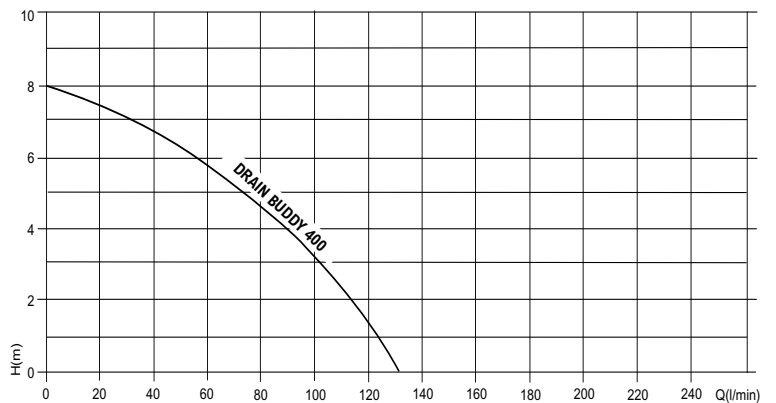
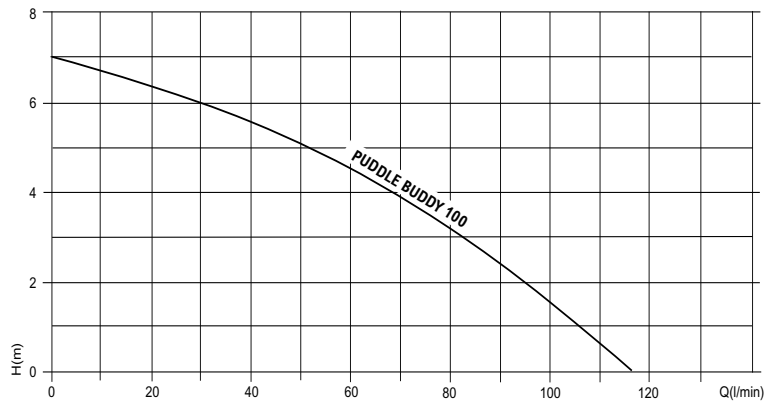

**PUDDLE BUDDY 100
REAR VIEW**



DRAIN BUDDY 400

MODEL	VOLTAGE	OUTLET	LM/HM	Kw	AMPS	H x W x L mm	Kg	CODE
PUDDLE BUDDY 100 AUTO	230v	1½”	117/7	0.25	1.7	270 x 169 x 265	4.9	012-100
DRAIN BUDDY 400 AUTO	230v	1½”	117/8	0.25	1.7	300 x 160 x 230	4.8	020-032

Vort Buddy 400 & 900 are for dirty water containing soft solids. 10 metres of power cable. 1½” Outlet with step adapter hose tail for 1¼” and 1” hose. Sump Buddy as above but with sliding tube float switch for applications where smaller application dimensions and a cable float will not operate. Can switch between manual and automatic. Turns on at approx 180mm water level and off at 80mm water level. 1½” Outlet with step adapter hose tail for 1¼” and 1” hose. Complete with 10 metres of power cable.

Features

Vortex Impeller
Automatic

Applications

Drainage
Sumps
Cellers

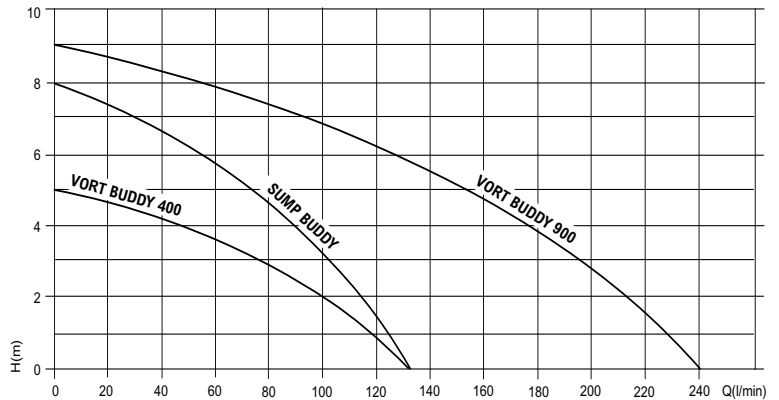

VORT BUDDY 400



VORT BUDDY 900



SUMP BUDDY AUTO



SUMP BUDDY AUTO REAR

MODEL	VOLTAGE	OUTLET	LM/HM	Kw	AMPS	H x W x L mm	Kg	CODE
VORT BUDDY 400 MANUAL	230v	1½”	133/5	0.25	1.7	335 x 155 x 230	5.0	020-039
VORT BUDDY 400 AUTO	230v	1½”	133/5	0.25	1.7	335 x 155 x 230	5.1	020-040
VORT BUDDY 900 AUTO	230v	1½”	233/8.5	0.55	3.9	335 x 155 x 230	6.7	020-042
SUMP BUDDY AUTO	230v	1½”	135/8	0.4	1.7	335 x 155 x 265	5.0	020-096

This high powered Spa pump is used purely for Swim spas as they benefit from having large 50mm suction and discharge connections on the wet end. This pump is designed for below water level (flooded suction) applications. Make sure the pump is installed at a level that will allow the pump casing (volute) to be completely filled with water. Complete with 50mm glue fit connections. Do not run dry. Air switch within the terminal box which allows the connection on the outside of the air start switch tube.

Features

50mm Suction
High Flow

Applications

Spa's

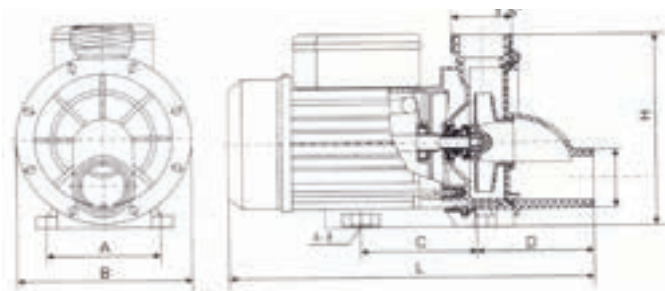
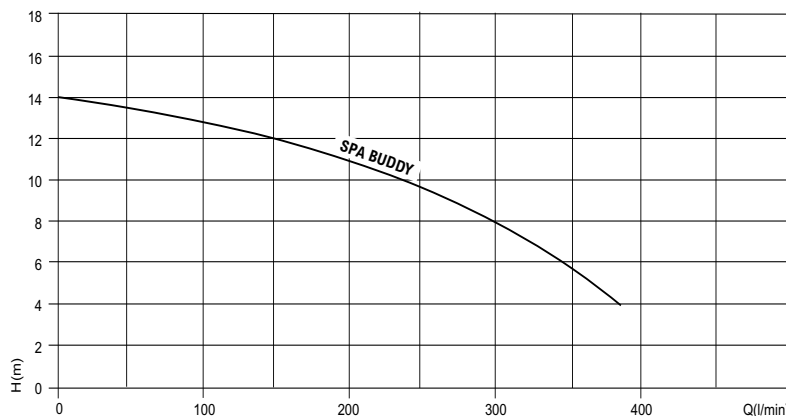

A (MM)	B (MM)	C (MM)	D (MM)	H (MM)	L (MM)
124	186	120	127	218	402

MODEL	VOLTAGE	INLET / OUTLET	LM/HM	Kw	AMPS	H x W x L mm	Kg	CODE
SPA BUDDY MASTER	230v	50mm x 50mm	380/14	1.1	5.8	218 x 186 x 402	12	014-280

Suitable for the recycling and filtering of swimming pool water. Built in motor thermal protection, continuous duty. Pump body and diffuser made from polypropylene, impeller Noryl, shaft in stainless steel, carbon mechanical seal. Maximum suction height 1.5 metres. Maximum Fluid temperature 50°C. 1½” Internal threaded connections and supplied are two 50mm glue fit fittings, complete with union nut for the outer thread. Self priming to 1.5 metres.

Features

- Circulation
- Self Priming
- High Volume

Applications

- Swimming Pools
- Salt Water

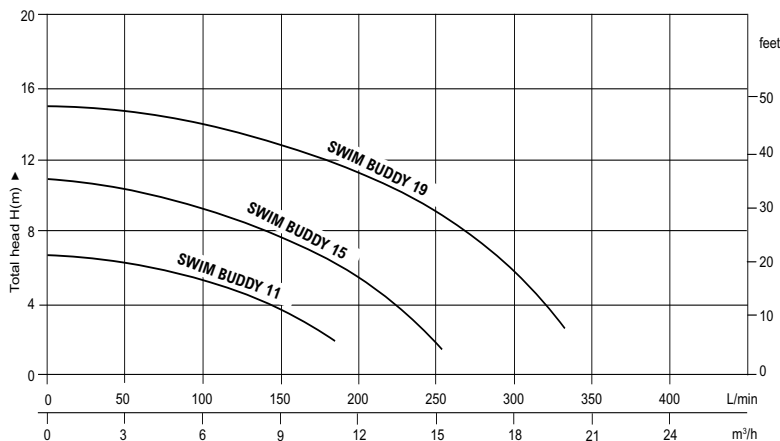

MODEL	VOLTAGE	INLET / OUTLET	LM/HM	Kw	AMPS	H x W x L mm	Kg	CODE
SWIM BUDDY 11	230v	1½” / 50mm x 1½” / 50mm	190/7	0.18	1.6	265 x 220 x 502	6	014-200
SWIM BUDDY 15	230v	1½” / 50mm x 1½” / 50mm	280/11	0.37	3.2	265 x 220 x 502	7	014-202
SWIM BUDDY 19	230v	1½” / 50mm x 1½” / 50mm	340/14	0.6	4.6	265 x 220 x 502	9.0	014-204

FLOOD PROTECTION

FLOODBOX PUMPING KITS

A

Floodbox pumping kits are ideal for defending properties – both domestic and commercial – in the event of flooding. Complete with water pump, electric or engine driven, quick fit hoses, floodsacks and each carry cage basket which can be used to filter out debris and leaves. These pumping kits are ready to use. (Engine pump will require oil for engine and petrol before use. Electric pumps will require a power source, mains electricity or a generator).



FLOODBOX 1



FLOODBOX 2



FLOODBOX 3



FLOODBOX 4



HYDROSLAKE



FLOODBOX 5



HYDROSACK

PHOTOS ARE FOR ILLUSTRATION PURPOSES ONLY. PHOTOS SHOWN WITH WHITE FLOODSACKS WILL BE REPLACED WITH 2 x HYDROSLAKES & 2 x HYDROSACKS

- FLOODBOX 1
PUDDLE BUDDY** 1 x Puddle Buddy 230v submersible low level pump, 20 metres of 1" layflat hose both fitted with quick release cam fittings, 2 x HydroSnakes & 2 x HydroSacks. For full data on pump see page 10.
- FLOODBOX 2
SEH25** 1 x SEH25 Honda powered engine pump, 5 metres of suction hose with footvalve, 20 metres of layflat discharge hose all fitted with quick release cam fittings, 2 x HydroSnakes & 2 x HydroSacks. For full data on pump see page 96.
- FLOODBOX 3
RSD400** 1 x RSD Residue 230v submersible low level pump, 20 metres of 1" layflat hose both fitted with quick release cam fittings, 2 x HydroSnakes & 2 x HydroSacks. For full data on pump see page 13.
- FLOODBOX 4
PXL** 1 x PXL Residue 230v submersible low level pump, 20 metres of 1" layflat hose both fitted with quick release cam fittings, 2 x HydroSnakes & 2 x HydroSacks. For full data on pump see page 12.
- FLOODBOX 5
PBX** 1 x Ponstar PBX 230v submersible, 20 metres of 2" layflat hose both fitted with quick release cam fittings, 2 x HydroSnakes & 2 x HydroSacks. For full data on pump see page 15.

MODEL	PUMP MODEL	BOX SIZE	Kg	CODE
FLOODBOX 1	PUDDLE BUDDY 230v	350 x 420 x 620	9.5	9000-4020
FLOODBOX 2	SEH25 ENGINE PUMP	350 x 420 x 620	20	9000-4025
FLOODBOX 3	RSD400 RESIDUE PUMP 230v	350 x 420 x 620	26	9000-4030
FLOODBOX 4	PXL RESIDUE PUMP 230v	350 x 420 x 620	24	9000-4035
FLOODBOX 5	PONSTAR PBX PUMP 230v	350 x 420 x 620	28	9000-4040

FLOOD PROTECTION

HYDROSLAKE & HYDROSACK

C

The HydroSnake & HydroSack's are a water-reactive temporary flood barriers for low-level flooding, constructed from a non-woven outer material with a super absorbent core. The super absorbent core contains a mixture of superabsorbent polymer and wood pulp. Before use, the HydroSnake & HydroSack weigh less than 0.5kg, but once they come into contact with water (absorption capacity up to 20 litres), it can then be used to defend against, and redirect floodwater. Each HydroSnake measures up to 1.45m in length when activated, making it the ideal flood barrier for warehouse doors/shutters and domestic doorways. The HydroSack's handles allow minimal contact, and allow easy positioning of the barrier, making them an ideal replacement for the traditional sandbag in forming a flood protection barrier. After use, the outer sack can be slit and the contents can be emptied into the earth without any harmful effects.



HYDROSLAKE



HYDROSACK



MODEL	DESCRIPTION	H x W x l (PACK – DRY)	Kg (DRY)	CODE
HYDROSLAKE	1 PACK OF 2 HYDROSLAKES	440 x 190 x 110	1.5	9000-4005
HYDROSACK	1 PACK OF 2 HYDROSACKS	440 x 190 x 110	1.5	9000-4010

ELECTRIC MOTORS

SINGLE AND THREE PHASE METRIC MOTORS B3, B5 AND B14



MODEL B3



MODEL B5



MODEL B14

SINGLE PHASE PERMANENT CAPACITOR 2800 RPM 230V 50HZ

D

MODEL/CODE	Kw	HP	RPM	AMP	uF	L x W x H	SHAFT	Kg
MM 71 A2	0.37	0.5	2800	2.9	14	242 x 135 x 160	14 mm	5.7
MM 71 B2	0.55	0.75	2800	4.2	16	242 x 135 x 160	14 mm	7.1
MM 80 A2	0.75	1.0	2800	5.1	25	278 x 152 x 228	19 mm	10.5
MM 80 B2	1.1	1.5	2800	7.2	30	278 x 152 x 228	19 mm	12
MM 90 S2	1.5	2.0	2800	9.1	40	303 x 170 x 242	24 mm	14
MM 90 L2	2.2	3.0	2800	13	50	328 x 170 x 242	24 mm	17.5

SINGLE PHASE PERMANENT CAPACITOR 1400 RPM 230V 50HZ

D

MODEL/CODE	Kw	HP	RPM	AMP	uF	L x W x H	SHAFT	Kg
MM 71 B4	0.37	0.5	1400	2.6	12.5	242 x 135 x 160	14 mm	6.8
MM 80 A4	0.55	0.75	1400	4.5	20	278 x 152 x 228	19 mm	9
MM 80 B4	0.75	1.0	1400	6.1	25	278 x 152 x 228	19 mm	10.7
MM 90 S4	1.1	1.5	1400	7.1	35	303 x 170 x 242	24 mm	14
MM 90 L4	1.5	2.0	1400	9.2	40	328 x 170 x 242	24 mm	17
MM 100 L4	2.2	3.0	1400	13.5	60	370 x 192 x 265	28 mm	21.5

THREE PHASE ELECTRIC MOTORS 2800 RPM 400V 50HZ

D

MODEL/CODE	Kw	HP	RPM	AMP	VOLTAGE	L x W x H	SHAFT	Kg
MT 71 A2	0.37	0.5	2800	0.98	220-400	242 x 135 x 180	14 mm	5.7
MT 71 B2	0.55	0.75	2800	1.4	220-400	242 x 135 x 180	14 mm	7.1
MT 80 A2	0.75	1.0	2800	2	220-400	278 x 152 x 202	19 mm	7.6
MT 80 B2	1.1	1.5	2800	2.4	220-400	278 x 152 x 202	19 mm	6
MT 90 S2	1.5	2.0	2800	3.2	220-400	303 x 170 x 214	24 mm	12.5
MT 90 L2	2.2	3.0	2800	4.5	220-400	328 x 170 x 214	24 mm	15.3
MT 100 L2	3.0	4.0	2800	6.4	220-400	370 x 192 x 236	28 mm	19.8
MT 112 M2	4.0	5.5	2800	8	220-400	388 x 220 x 262	28 mm	28
MT 132 SA2	5.5	7.5	2800	10.5	400-690	459 x 260 x 310	38 mm	41.5
MT 132 SB2	7.5	10	2800	13.8	400-690	459 x 260 x 310	38 mm	44.5
MT 160 MA2	11	15	2800	20.6	400-690	605 x 318 x 382	42 mm	75
MT 160 MB2	15	20	2800	27.4	400-690	605 x 318 x 382	42 mm	86

ELECTRIC MOTORS

THREE PHASE ELECTRIC MOTORS 1400 RPM 400V 50HZ

D

MODEL/CODE	Kw	HP	RPM	AMP	VOLTAGE	L x W x H	SHAFT	Kg
MT 71 B4	0.37	0.5	1400	1.06	220-400	242 x 135 x 180	14 mm	6.6
MT 80 A4	0.55	0.75	1400	1.6	220-400	278 x 152 x 202	19 mm	9
MT 80 B4	0.75	1.0	1400	2	220-400	278 x 152 x 202	19 mm	10.6
MT 90 S4	1.1	1.5	1400	2.7	220-400	303 x 170 x 214	24 mm	12.6
MT 90 L4	1.5	2.0	1400	3.4	220-400	328 x 170 x 214	24 mm	14.7
MT 100 LA4	2.2	3.0	1420	4.9	220-400	370 x 192 x 236	28 mm	20
MT 100 LB4	3.0	4.0	1400	6.5	220-400	370 x 192 x 236	28 mm	21
MT 112 M4	4.0	5.5	1400	8.2	220-400	388 x 220 x 262	28 mm	31
MT 132 S4	5.5	7.5	1400	11.6	400-690	459 x 260 x 310	38 mm	43
MT 132 MA4	7.5	10	1400	15.7	400-690	497 x 260 x 310	38 mm	50.5
MT 160 M4	11	15	1400	22.5	400-690	605 x 318 x 382	42 mm	82
MT 160 L4	15	20	1400	30.5	400-690	648 x 318 x 382	42 mm	97

Prices are for B3 flanged motors 230v & 400v. For B5 or B14 flanges add 7%, or Foot & Flange mount add 9%.

LARGER MOTORS AVAILABLE ON REQUEST



MODEL B3



MODEL B5



MODEL B14

MOTOR STARTERS STEEL ENCLOSURE D.O.L./N.V.R STARTERS

D

CODE	PHASE	AMP	PRICE	CODE	PHASE	AMP
040-006	1	1.6 - 2.5	£90	040-020	3	1.0 - 1.6
040-007	1	2.5 - 4.0	£90	040-021	3	1.6 - 2.5
040-008	1	4.0 - 6.0	£90	040-022	3	2.5 - 4.0
040-009	1	5.5 - 8.0	£90	040-023	3	4.0 - 6.0
040-010	1	7.0 - 10.0	£90	040-024	3	5.5 - 8.0
040-011	1	10.0 - 13.0	£90	040-025	3	7.0 - 10.0
040-012	1	13.0 - 18.0	£90	040-026	3	10.0 - 13.0

PRESSURE BOOSTING SYSTEMS

STUART TURNER

C

Stuart Turner manufacture and supply a variety of pump ranges including solutions for low water pressure, such as mains boost pumps and shower pumps. Below are a selection of the best and most popular range of shower pumps single and twin. All models have 3/4" male inlets and outlets and also come with either 3/4" female to 15mm or 22mm push fit flexible connection hoses depending on the model. S-Standard models are for positive head applications only. U-Universal models are for both positive and negative head applications.

Features

High Pressure
Automatic

Applications

Water Boosting
Shower Boosting



SHOWERMATE STANDARD



SHOWERMATE UNIVERSAL

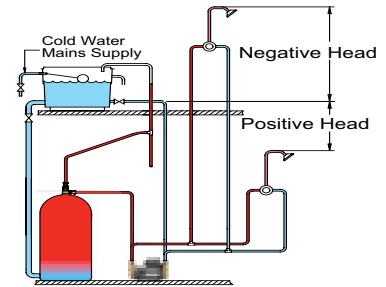

MONSOON STANDARD



MONSOON UNIVERSAL



MODEL	VOLTAGE	INLET/ OUTLET	LM/HM	Kw	AMP	Kg	CODE
SHOWERMATE S1.5 TWIN	230v	3/4" x 3/4" 15mm	32/15	0.385	1.7	4.7	STU-47342
SHOWERMATE S2.0 TWIN	230v	3/4" x 3/4" 15mm	37/20	0.42	1.8	4.7	STU-47343
SHOWERMATE U2.0 TWIN	230v	3/4" x 3/4" 15mm	40/20	0.43	1.9	6.1	STU-47376
MONSOON S2.0 TWIN	230v	3/4" x 3/4" 15mm	55/20	0.425	1.9	7.2	STU-46415
MONSOON S3.0 TWIN	230v	3/4" x 3/4" 15mm	60/30	0.64	2.8	7.5	STU-46416
MONSOON U2.0 TWIN	230v	3/4" x 3/4" 15mm	35/20	0.435	1.9	8.8	STU-46480
MONSOON U3.0 TWIN	230v	3/4" x 3/4" 22mm	40/30	0.655	2.9	9.2	STU-46410

W. ROBINSON & SONS



PUMPS & PUMPING